

NanoPower P80

Datasheet

Datasheet for the NanoPower P80

NanoPower P80

Datasheet for the NanoPower P80

© Copyright 2024 GomSpace A/S. All rights reserved.

Document reference: DS 1047423

Source reference: doc-nanopower-p80-datasheet

Date: April 19, 2024

Revision: 2.2.0

Information contained in this document is up-to-date and correct as at the date of issue. As GomSpace A/S cannot control or anticipate the conditions under which this information may be used, each user should review the information in specific context of the planned use. To the maximum extent permitted by law, GomSpace A/S will not be responsible for damages of any nature resulting from the use or reliance upon the information contained in this document. No express or implied warranties are given other than those implied mandatory by law.



GomSpace A/S

Langagervej 6, 9220 Aalborg East

Denmark

Phone: +45 71 741 741

www.gomspace.com

Contents

List of Figures	iv
List of Tables	v
List of Abbreviations	vi
1 Introduction	1
1.1 Overview	1
1.2 Highlighted features	1
1.3 Functional description	2
1.3.1 Power paths	2
1.3.2 Hardware interfaces	3
1.3.3 Killswitch functionality	3
1.3.4 PMU Flight preparation panel (FPP)	3
1.3.5 ACU MPPT hardware fallback	3
1.3.6 Watchdogs	3
1.3.7 PMU and PDU battery voltage level	4
1.4 Configuration options	5
1.4.1 PDU channel configuration	6
2 Specifications	7
2.1 Absolute maximum	7
2.2 Electrical characteristics	7
2.3 Typical characteristics	8
2.3.1 PDU regulated output efficiency	8
3 Hardware layout	9
3.1 Overview	9
3.1.1 Sideview A	9
3.1.2 Sideview B	10
3.1.3 Sideview C	10
3.1.4 Sideview D	11
3.2 PDU connectors	12
3.2.1 J3, J4, J5, J7, J8, J9 - Output channels	12
3.2.2 J6 - Debugging and configuration	13
3.3 ACU connectors	14
3.3.1 J2, J3 - Photovoltaic inputs	14
3.3.2 J1 - Debugging and configuration	15
3.4 PMU connectors	16
3.4.1 J1 and J13 - Battery connectors	16
3.4.2 J2 - RBF Onboard Jumper	17
3.4.3 J3, J4 - Release GSSB/Deployment	17
3.4.4 J5 - Debugging and configuration	18
3.4.5 J6, J7 - Kill Switch	19
3.4.6 J8 and J9 - Main bus	19
3.4.7 J11 - Flight Preparation Panel (FPP)	20

3.4.8	J12 - Flight Preparation Panel (FPP)	20
4	Physical Dimensions	21
5	References	22

List of Figures

1.1	The standard NanoPower P80 with a single PMU, ACU and PDU.	1
1.2	Block diagram of the NanoPower P80 system. The black arrows show the power paths, while the blue shows communication.	2
1.3	Block diagram of power paths in the NanoPower P80 system. The PM-modules illustrate power measurements (voltage and current readings).	2
2.1	Efficiency of the regulated output channels at different input voltages (23.3 V, 28.8 V and 32.0 V).	8
3.1	Sideview of P80 connectors in a PDU, ACU, PMU configuration	9
3.2	Sideview of the A-side	9
3.3	Sideview of the B-side	10
3.4	Sideview of the C-side	10
3.5	Sideview of the D-side	11
4.1	Mechanical drawing of the standard P80, 1xPMU 1xACU 1xPDU.	21

List of Tables

1.1	Standard configurations for P80	5
1.2	Channel configuration options for P80 PDU.	6
2.1	Absolute maximum specifications	7
2.2	Electrical specifications for the P80	7
3.1	Connector description for sideview A	9
3.2	Connector description for sideview B	10
3.3	Connector description for sideview C	11
3.4	Connector description for sideview D	11
3.5	Overview of connectors on the PDU	12
3.6	Pinout for J3,J4,J5,J7,J8 and J9.	12
3.7	Output channel mapping for Table 3.6	12
3.8	Pinout for PDU J6	13
3.9	Overview of connectors on the ACU	14
3.10	Pinout for ACU J2 and J3.	14
3.11	Photovoltaic input channel mapping for Table 3.10	14
3.12	Pinout for ACU J1	15
3.13	Pinout of battery connector J1 and J13	16
3.14	Pinout for PMU J2	17
3.15	Pinout for PMU J3	17
3.16	Pinout for PMU J4	17
3.17	Pinout for PMU J5	18
3.18	Pinout for PMU J6	19
3.19	Pinout for PMU J7	19
3.20	Pinout of PMU J8 and J9	19
3.21	Pinout of PMU J11	20
3.22	Pinout of PMU J12	20
4.1	Physical measurements of the standard P80 configurations. Refer to Table 1.1 for configuration names.	21

List of Abbreviations

ACU Array Conditioning Unit.

CAN Controller Area Network.

CSP Cubesat Space Protocol.

EPS Electrical Power System.

GSSB GomSpace Sensor Bus.

I2C Inter-Integrated Circuit.

LUP Latch-up Protection.

MCU microcontroller unit.

MPPT Maximum Power Point Tracking.

PDU Power Distribution Unit.

PMU Power Management Unit.

1 Introduction

1.1 Overview

The NanoPower P80 is an Electrical Power System (EPS) for small satellites, based on GomSpaces earlier EPS, the NanoPower P60 system. The P80 consists of a Power Management Unit (PMU), Array Conditioning Unit (ACU) and a Power Distribution Unit (PDU), stacked on top of each other and fitted into an enclosure with mounting brackets that functions as shield and provides thermal dissipation, see Figure 1.1. The unit fits in a standard PC104 form, but does not support the PC104 stack connector.



Figure 1.1: The standard NanoPower P80 with a single PMU, ACU and PDU.

1.2 Highlighted features

- Power Management Unit (PMU)
 - EPS master
 - Handling of battery modes
 - Killswitch (KS) logic
 - Deploy device control
 - Four power modes depending on battery voltage
- Array Conditioning Unit (ACU)
 - 2x6 Maximum Power Point Tracking (MPPT) boost converters
 - KS/Remove Before Flight (RBF) inhibit switch
 - Software and hardware Latch-up Protection (LUP)
- Power Distribution Unit (PDU)
 - 12 low voltage LUP channels, fed by 4 converters. All low voltage channels can be configured to an arbitrary converter in hardware.
 - 12 high voltage LUP channels - raw battery channels.
 - Handling of battery modes.
 - Software and hardware LUP.
 - Four power modes depending on battery voltage.

1.3 Functional description

The P80 is made up of three submodules; the PMU, PDU and ACU. The submodules are stacked on top of each-other, allowing power and communication to flow between the individual boards. An overview of the P80 system is illustrated in Figure 1.2.

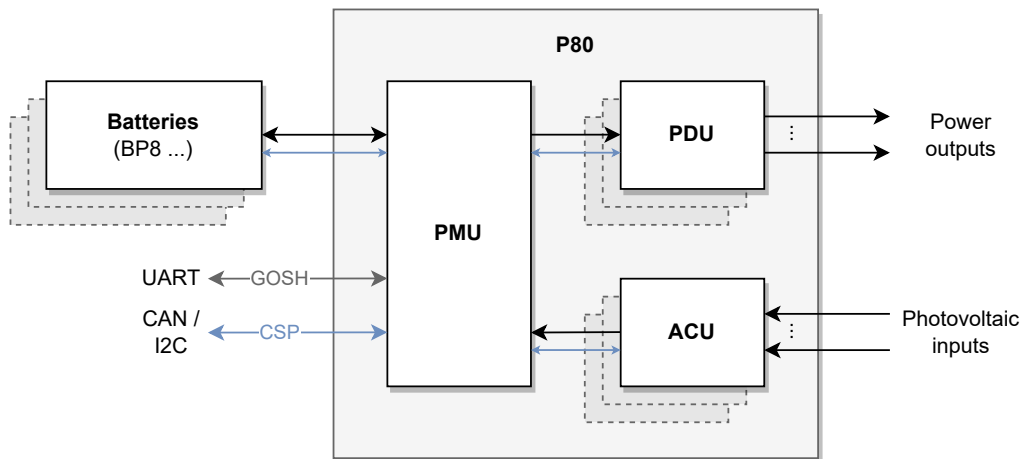

Figure 1.2: Block diagram of the NanoPower P80 system. The black arrows show the power paths, while the blue shows communication.

NOTE: The battery (NanoPower BP8) is not part of the EPS, but a separate product.

1.3.1 Power paths

The three submodules share a common power bus, that feeds all subsystems and allows for charging and discharging of the connected batteries. This is illustrated in Figure 1.3.

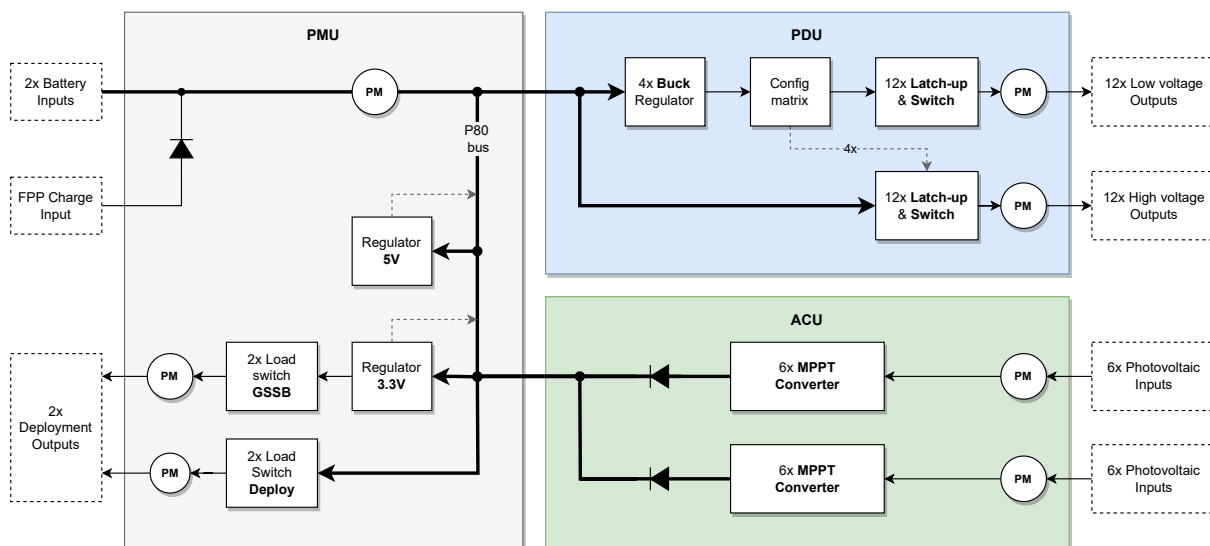

Figure 1.3: Block diagram of power paths in the NanoPower P80 system. The PM-modules illustrate power measurements (voltage and current readings).

1.3.2 Hardware interfaces

The P80 uses the Cubesat Space Protocol (CSP) to transfer data to and from CSP nodes on-board the main system bus. CSP is a routed network protocol that is used to transmit data packets between individual subsystems on the satellite bus and between the satellite and ground station. On the P80 the CSP network layer protocol spans multiple data-link layer protocols, being:

- Controller Area Network (CAN)
- Inter-Integrated Circuit (I2C)

1.3.3 Killswitch functionality

The P80 has interface for two killswitches (KS) / inhibits. The killswitch functionality powers off the entire P80 EPS allowing for long-term storage before flight. When the P80 is killswitched with a NanoPower BP8 battery pack connected, the killswitch inhibits both P80 and BP8.

1.3.4 PMU Flight preparation panel (FPP)

The FPP interface can be used by the operator to perform system checks before flight. The interface has provisions for CAN (the main bus), Remove Before Flight (RBF) inhibit, deploy inhibit, KS override, a charge mode only pin and a charge input.

1.3.5 ACU MPPT hardware fallback

In case power to the ACU is switched OFF, meaning the MCU is not powered and the MPPT is not active, the ACU will go into a hardware set fallback mode, where the MPPT point will be set to 9.5 V and the boost converter is powered by the solar input. This mode will continue to deliver power to the system and charge the batteries until the internal supply to the ACU are enabled again.

1.3.6 Watchdogs

The P80 system implements a few different watchdogs to watch the systems operational state.

- **Hardware watchdog:** Monitors each microcontroller unit (MCU) and resets if it is not responding.
- **Bus watchdog:** Monitors the satellite bus, and resets the submodule if no traffic is received.
- **Ground watchdog:** Monitors that a connection to ground (earth) has been made within a configurable interval. Resets the submodule and restores default configuration if no connection has been made.

The P80 PMU has an optional feature that allows to propagate the ground watchdog reset message to all P80 submodules.

1.3.7 PMU and PDU battery voltage level

The P80 PMU and PDU module has software low voltage protection and will automatically turn channels on and off depending on battery voltage level.

1.4 Configuration options

The NanoPower P80 can be configured in many different configurations. A P80 must have one PMU, while the number of PDU's and ACU's can be varried. Table 1.1 shows an overview of the 9 different standard configurations offered by GomSpace.

Table 1.1: Standard configurations for P80

Config #	Config Name	PMU	ACU	PDU
1	1xPMU, 1xACU, 1xPDU	1	1	1
2	1xPMU, 1xACU, 2xPDU	1	1	2
3	1xPMU, 1xACU, 3xPDU	1	1	3
4	1xPMU, 2xACU, 4xPDU	1	2	1
5	1xPMU, 2xACU, 2xPDU	1	2	2
6	1xPMU, 0xACU, 1xPDU	1	0	1
7	1xPMU, 0xACU, 2xPDU	1	0	2
8	1xPMU, 0xACU, 3xPDU	1	0	3
9	1xPMU, 0xACU, 4xPDU	1	0	4

1.4.1 PDU channel configuration

The PDU's output channels can be configured in many ways, see Table 1.2 for an overview. Some channels can be configured as combined outputs, to increase the current capacity of a single channel. The channel configuration is hardware-based and cannot be changed in software later on.

Table 1.2: Channel configuration options for P80 PDU.

Channel	Type	Regulator	Voltage [V]	Max current [A]	Combined Channel
Ch0	Vbat	N/A	Vbat	2	Ch0
Ch1	Vbat	N/A	Vbat	2	Ch0
Ch2	Vbat	N/A	Vbat	2	-
Ch3	Vbat	N/A	Vbat	2	-
Ch4	Vbat	N/A	Vbat	2	Ch4
Ch5	Vbat	N/A	Vbat	2	Ch4
Ch6	Vbat	N/A	Vbat	2	-
Ch7	Vbat	N/A	Vbat	2	-
Ch8	HV reg	3	Vbat or 3.3 5 12 V or 18V	2	Ch8
Ch9	HV reg	3	Vbat or 3.3 5 12 V or 18V	2	Ch8
Ch10	HV reg	3	Vbat or 3.3 5 12 V or 18V	2	-
Ch11	HV reg	3	Vbat or 3.3 5 12 V or 18V	2	-
Ch12	LV reg	0 1 2 3	3.3 5 or 12 V	2	Ch12
Ch13	LV reg	0 1 2 3	3.3 5 or 12 V	2	Ch12
Ch14	LV reg	0 1 2 3	3.3 5 or 12 V	2	-
Ch15	LV reg	0 1 2 3	3.3 5 or 12 V	2	-
Ch16	LV reg	0 1 2 3	3.3 5 or 12 V	2	Ch16
Ch17	LV reg	0 1 2 3	3.3 5 or 12 V	2	Ch16
Ch18	LV reg	0 1 2 3	3.3 5 or 12 V	2	-
Ch19	LV reg	0 1 2 3	3.3 5 or 12 V	2	-
Ch20	LV reg	0 1 2 3	3.3 5 or 12 V	2	Ch21
Ch21	LV reg	0 1 2 3	3.3 5 or 12 V	2	Ch21
Ch22	LV reg	0 1 2 3	3.3 5 or 12 V	2	-
Ch23	LV reg	0 1 2 3	3.3 5 or 12 V	2	-

2 Specifications

2.1 Absolute maximum

Stresses at or beyond those given in Table 2.1 may cause permanent damage and affect the reliability of any of the P80 submodules.

Table 2.1: Absolute maximum specifications

Parameter	Min	Typ	Max	Unit
T _{OP} Operating temperature	-40.0		85.0	°C
V _{IO} Voltage on I2C/USART/GPIO pins	-0.1		3.4	V

2.2 Electrical characteristics

The electrical specifications for the P80 are given in Table 2.2.

Table 2.2: Electrical specifications for the P80

Parameter	Condition	Min	Typ	Max	Unit
PMU					
V _{IN} Operating voltage			28.8	33.6	V
P _{IDL} Idle power consumption	All features enabled		500		mW
I _{TOT} Total input/output current				12.0	A
I _{FPP} FPP charge current				10.0	A
PDU					
P _{IDL} Idle power consumption	All channels disabled		450		mW
I _{DCDC} Output current per converter (0-3)	I _{TOT} < 12A			4.0	A
I _{CH} Output current per channel (0-23)	I _{TOT} < 12A			2.0	A
t _{LTC} Latch-up time	High voltage channels (0-11) Low voltage channels (12-23)		0.02 1.3		ms
ACU					
P _{IDL} Idle power consumption	All features enabled		300		mW
V _{PV} PV input voltage	V _{OC} < max(V _{BAT}) ¹			25.0	V

Continued on next page

Table 2.2: Electrical specifications for the P80 (Continued)

Parameter		Condition	Min	Typ	Max	Unit
I_{PV}	PV input current per channel (0-11)	$I_{TOT} < 12A$			1.1	A

¹ The open circuit voltage V_{OC} of the PV cell must be less than the maximum rated voltage of V_{BAT} .

⚠ CAUTION: Care must be taken when long cables are used for connection as the inductive characteristic of the cable if coupled with a voltage step can generate voltage spikes of magnitudes higher than the acceptable range of the unit causing damage.

2.3 Typical characteristics

2.3.1 PDU regulated output efficiency

The efficiency of the regulated output channels on the PDU depends largely on the battery voltage and the configured output voltage. Measurements of the 3.3 V, 5 V and 12 V outputs are illustrated Figure 2.1.

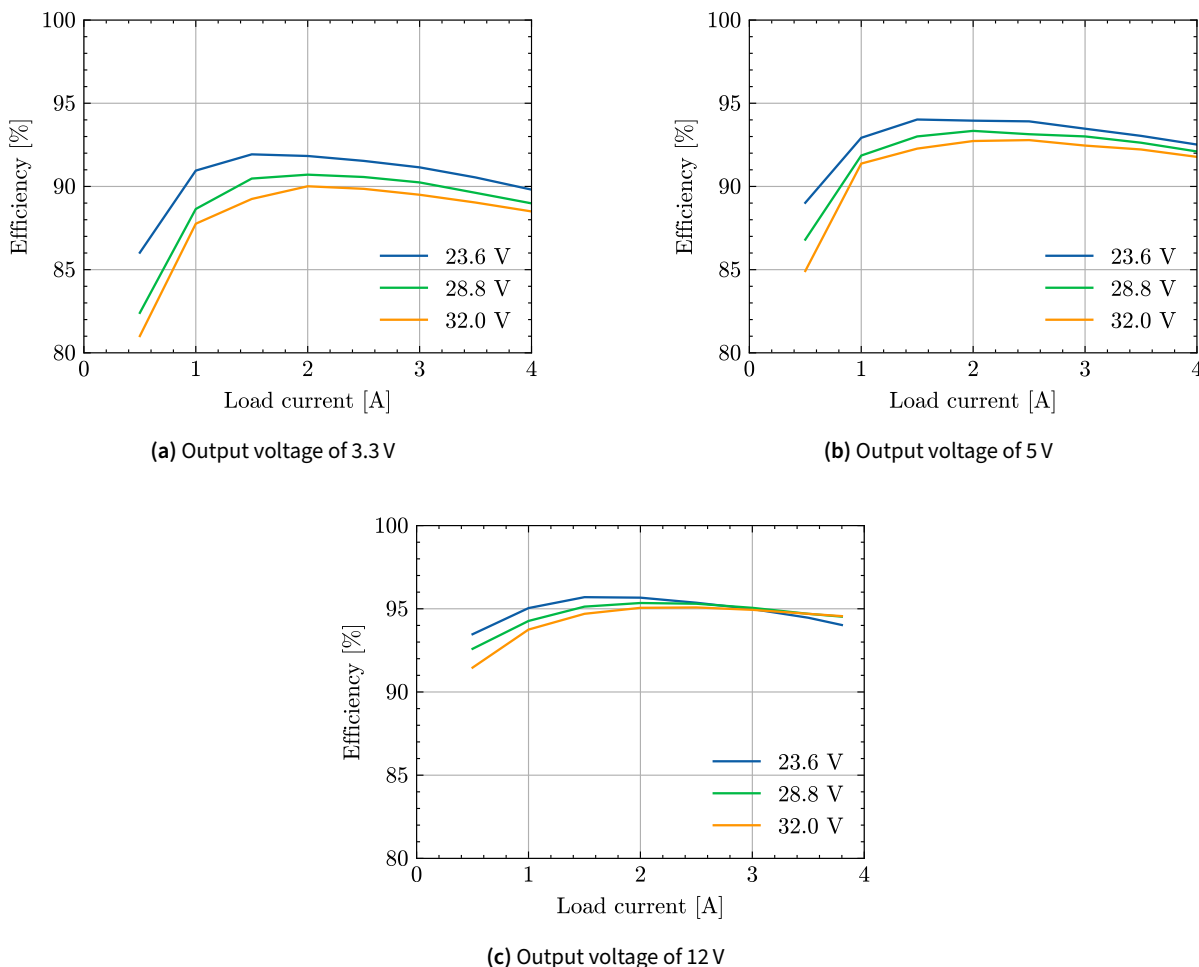

Figure 2.1: Efficiency of the regulated output channels at different input voltages (23.3 V, 28.8 V and 32.0 V).

3 Hardware layout

3.1 Overview

The three units in a standard P80 stack are from top to bottom: the PDU, ACU and PMU, respectively. Connectors are placed on all four sides of the stack. The four sides are labeled as shown below in Figure 3.1.

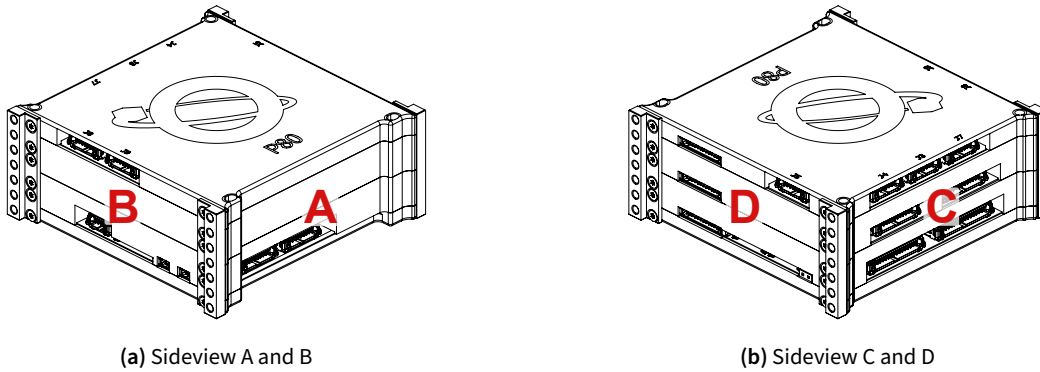

Figure 3.1: Sideview of P80 connectors in a PDU, ACU, PMU configuration

3.1.1 Sideview A

Side-A has connectors from the PMU, this being:

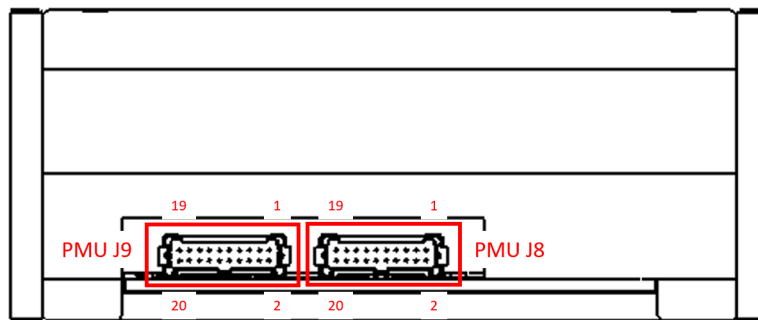

Figure 3.2: Sideview of the A-side

Table 3.1: Connector description for sideview A

Connector	Description	Type	Details
PMU J8	Main bus	Harwin Gecko G125-MH12005L1R	Section 3.4.6
PMU J9	Main bus	Harwin Gecko G125-MH12005L1R	Section 3.4.6

3.1.2 Sideview B

Side-B has connectors from both the PDU and PMU, this being:

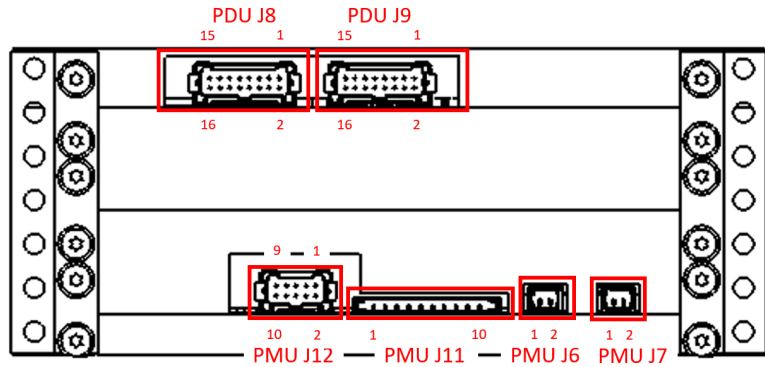

Figure 3.3: Sideview of the B-side

Table 3.2: Connector description for sideview B

Connector	Description	Type	Details
PDU J8	Outputs	Harwin Gecko G125-MH11605L1R	Section 3.2.1
PDU J9	Outputs	Harwin Gecko G125-MH11605L1R	Section 3.2.1
PMU J6	Kill switch	Molex PicoBlade 053261-0271	Section 3.4.5
PMU J7	Kill switch	Molex PicoBlade 053261-0271	Section 3.4.5
PMU J11	Flight Preparation Panel (FPP)	Molex 1.5 mm PicoLock - 504050-1091	Section 3.4.7
PMU J12	Flight Preparation Panel (FPP)	Harwin Gecko G125-MH11005L1R	Section 3.4.8

3.1.3 Sideview C

Side-C has connectors from all submodules; the PDU, ACU and PMU, this being:

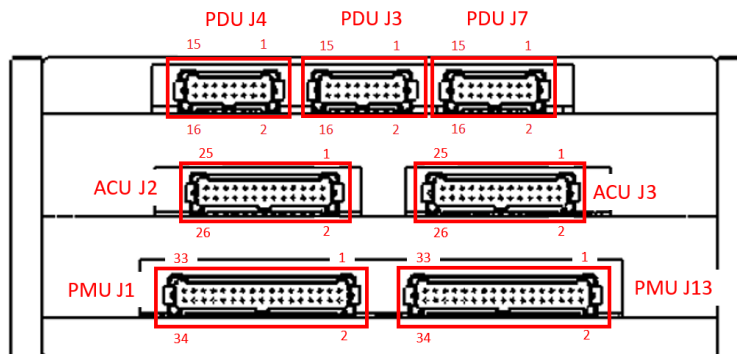

Figure 3.4: Sideview of the C-side

Table 3.3: Connector description for sideview C

Connector	Description	Type	Details
PDU J3	Outputs	Harwin Gecko G125-MH11605L1R	Section 3.2.1
PDU J4	Outputs	Harwin Gecko G125-MH11605L1R	Section 3.2.1
PDU J7	Outputs	Harwin Gecko G125-MH11605L1R	Section 3.2.1
ACU J2	PV Inputs	Harwin Gecko G125-MH12605L1P	Section 3.3.1
ACU J3	PV Inputs	Harwin Gecko G125-MH12605L1P	Section 3.3.1
PMU J1	Battery connector	Harwin Gecko G125-MH13405L1R	Section 3.4.1
PMU J13	Battery connector	Harwin Gecko G125-MH13405L1R	Section 3.4.1

3.1.4 Sideview D

Side-D has connectors from both the PDU, ACU and PMU, this being:

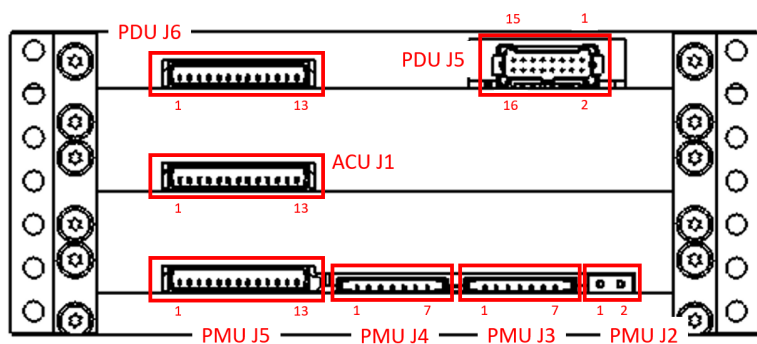

Figure 3.5: Sideview of the D-side

Table 3.4: Connector description for sideview D

Connector	Description	Type	Details
PDU J5	Outputs	Harwin Gecko - G125-MH11605L1R	Section 3.2.1
PDU J6	Debug connector	Molex PicoBlade 053261-1371	Section 3.2.2
ACU J1	Debug connector	Molex PicoBlade 053261-1371	Section 3.3.2
PMU J2	RBF Onboard Jumper	Samtec - SMH-102-02-G-S	Section 3.4.2
PMU J3	Release GSSB/Deployment	Molex 1.5 mm PicoLock - 504050-0791	Section 3.4.3
PMU J4	GSSB/Deployment	Molex 1.5 mm PicoLock - 504050-0791	Section 3.4.3
PMU J5	Debug connector	Molex PicoBlade 053261-1371	Section 3.4.4

3.2 PDU connectors

The PDU has a total of 7 connectors, listed in Table 3.5.

Designator	Description	Part No.
J3, J4, J5, J7, J8, J9	Output channels	Harwin Gecko - G125-MH11605L1R
J6	Debug and configuration	Molex PicoBlade - 053261-1371

Table 3.5: Overview of connectors on the PDU

3.2.1 J3, J4, J5, J7, J8, J9 - Output channels

Table 3.6 shows the general pinout of all output channel connectors on the PDU. Each connector has four channel outputs 1,2...4, refer to Table 3.7 for channel mapping.

Table 3.6: Pinout for J3,J4,J5,J7,J8 and J9.

Pin	Description	Pin	Description
1	Output-1	2	GND
3	Output-1	4	GND
5	Output-2	6	GND
7	Output-2	8	GND
9	Output-3	10	GND
11	Output-3	12	GND
13	Output-4	14	GND
15	Output-4	16	GND

Designator	Output-1	Output-2	Output-3	Output-4
J3	Channel 0	Channel 1	Channel 2	Channel 3
J4	Channel 4	Channel 5	Channel 6	Channel 7
J5	Channel 8	Channel 9	Channel 10	Channel 11
J7	Channel 12	Channel 13	Channel 14	Channel 15
J8	Channel 16	Channel 17	Channel 18	Channel 19
J9	Channel 20	Channel 21	Channel 22	Channel 23

Table 3.7: Output channel mapping for Table 3.6

3.2.2 J6 - Debugging and configuration

Table 3.8: Pinout for PDU J6

Pin	Description
1	RESERVED
2	RESERVED
3	RESERVED
4	RESERVED
5	RESET
6	RESERVED
7	GND
8	GOSH_RX
9	GOSH_TX
10	GND
11	NC
12	NC
13	GND

RESERVED: Reserved for GomSpace. Leave pins floating.

RESET: Reset pin on MCU (active low). Leave floating.

GOSH_RX Serial input (RX) for GOSH over UART. Used for configuration before flight.

GOSH_TX Serial output (TX) for GOSH over UART. Used for configuration before flight.

NC: Not connected.

GND: System ground.

3.3 ACU connectors

The ACU has a total of 3 connectors, listed in Table 3.9.

Designator	Description	Part No.
J1	Debug and configuration	Molex PicoBlade - 053261-1371
J2, J3	Photovoltaic inputs	Harwin Gecko - G125-MH12605L1P

Table 3.9: Overview of connectors on the ACU

3.3.1 J2, J3 - Photovoltaic inputs

J2 and J3 each consist of 6 photovoltaic inputs for charging, see Table 3.10 for pinout for both, and refer to Table 3.11 for channel mapping.

Table 3.10: Pinout for ACU J2 and J3.

Pin	Description	Pin	Description
1	Input-1	2	Input-1
3	GND	4	GND
5	Input-2	6	Input-2
7	GND	8	GND
9	Input-3	10	Input-3
11	GND	12	GND
13	Input-4	14	Input-4
15	GND	16	GND
17	Input-5	18	Input-5
19	GND	20	GND
21	Input-6	22	Input-6
23	GND	24	GND
25	GND	26	GND

Designator	Input-1	Input-2	Input-3	Input-4	Input-5	Input-6
J2	Channel 0	Channel 1	Channel 2	Channel 3	Channel 4	Channel 5
J3	Channel 6	Channel 7	Channel 8	Channel 9	Channel 10	Channel 11

Table 3.11: Photovoltaic input channel mapping for Table 3.10

3.3.2 J1 - Debugging and configuration

The debugging port for the ACU have two GOSH interfaces, one for each of the onboard MCU.

Table 3.12: Pinout for ACU J1

Pin	Description
1	RESERVED
2	RESERVED
3	RESERVED
4	RESERVED
5	RESET
6	RESERVED
7	GND
8	GOSH1_RX
9	GOSH1_TX
10	GND
11	GOSH2_RX
12	GOSH2_TX
13	GND

RESERVED: Reserved for GomSpace. Leave pins floating.

RESET: Reset pin on MCU (active low). Leave floating.

GOSHn_RX Serial input (RX) for GOSH over UART. Used for configuration before flight.

GOSHn_TX Serial output (TX) for GOSH over UART. Used for configuration before flight.

NC: Not connected.

GND: System ground.

3.4 PMU connectors

3.4.1 J1 and J13 - Battery connectors

Table 3.13: Pinout of battery connector J1 and J13

Pin	Description	Pin	Description
1	SDA0	2	CANH
3	GND	4	CANL
5	SCL0	6	GND
7	EN0	8	GND
9	EN1	10	GND
11	BLEED	12	KS
13	GND	14	GND
15	GND	16	GND
17	GND	18	GND
19	GND	20	GND
21	GND	22	GND
23	NC	24	NC
25	VBAT	26	VBAT
27	VBAT	28	VBAT
29	VBAT	30	VBAT
31	VBAT	32	VBAT
33	VBAT	34	VBAT

ENA0: Enable output pin (active low).

ENA1: Enable output pin (active low).

BLEED: Bleed pin. Allows a low current to flow between killswitched BP8's to balance voltage levels. Only relevant in multi-pack setups.

KS: Killswitch output (active low). Propagates the killswitch signal to the battery pack.

SDA0: Data line for the I2C bus.

SCL0: Clock line for the I2C bus.

CANH: High signal for the CAN bus.

CANL: Low signal for the CAN bus.

VBAT: Positive battery voltage input.

GND: Negative battery voltage output.

NC: Not connected.

3.4.2 J2 - RBF Onboard Jumper

Table 3.14: Pinout for PMU J2

Pin	Description
1	RBF
2	GND

RBF: Disables the P80, using the same functionality as killswitch (active low). **GND:** System ground.

3.4.3 J3, J4 - Release GSSB/Deployment

Connector J3 and J4 can be used for deployment and supply of sensors on the GomSpace Sensor Bus (GSSB). Both connectors have deployment- and supply-outputs that can be controlled individually. The two connectors share a single I2C bus (I2C1) but both I2C outputs are isolated, such that a failure on one does not harm the other.

Table 3.15: Pinout for PMU J3

Pin	Description
1	GND
2	SCL1
3	SDA1
4	GND
5	V_3V3_1
6	GND
7	V_DEP_1

Table 3.16: Pinout for PMU J4

Pin	Description
1	GND
2	SCL1
3	SDA1
4	GND
5	V_3V3_2
6	GND
7	V_DEP_2

SDA1: Data line for the I2C bus (isolated).

SCL1: Clock line for the I2C bus (isolated).

V_3V3_n: Controlable 3.3 V output to supply sensors on GSSB bus.

V_DEP_n: Controlable VBAT output to supply deploy system (0.5 A max load).

GND: System ground.

3.4.4 J5 - Debugging and configuration

Table 3.17: Pinout for PMU J5

Pin	Description
1	RESERVED
2	RESERVED
3	RESERVED
4	RESERVED
5	RESET
6	RESERVED
7	GND
8	GOSH_RX
9	GOSH_TX
10	GND
11	NC
12	NC
13	GND

RESERVED: Reserved for GomSpace. Leave pins floating.

RESET: Reset pin on MCU (active low). Leave floating.

GOSH_RX Serial input (RX) for GOSH over UART. Used for configuration before flight.

GOSH_TX Serial output (TX) for GOSH over UART. Used for configuration before flight.

NC: Not connected.

GND: System ground.

3.4.5 J6, J7 - Kill Switch

To killswitch the P80, a connection between KS on J6 and GND on J7 must be made. For redundancy, two normally open switches should be used, such that if one switch fails, the second will break the connection, powering on the P80. Connecting two switches to, respectively, J6 and J7 results in those two switches being connected in series.

Table 3.18: Pinout for PMU J6

Pin	Description
1	KS
2	KS_INTER

Table 3.19: Pinout for PMU J7

Pin	Description
1	KS_INTER
2	GND

KS_INTER: Series connection between J6 pin 2 and J7 pin 1.

KS: Killswitch input (active low).

GND: System ground.

3.4.6 J8 and J9 - Main bus

Table 3.20: Pinout of PMU J8 and J9

Pin	Description	Pin	Description
1	SDA0	2	CANH
3	GND	4	CANL
5	SCL0	6	NC
7	GND	8	NC
9	RESERVED	10	RESERVED
11	RESERVED	12	RESERVED
13	NC	14	RESERVED
15	GND	16	RESERVED
17	NC	18	RESERVED
19	GND	20	RESERVED

SDA0: Data line for the I2C bus.

RESERVED: Reserved for future use. Leave floating.

SCL0: Clock line for the I2C bus.

GND System ground.

CANH: High signal for the CAN bus.

NC: Not connected.

CANL: Low signal for the CAN bus.

3.4.7 J11 - Flight Preparation Panel (FPP)

Table 3.21: Pinout of PMU J11

Pin	Description
1	CANH
2	CANL
3	RBF
4	GND
5	Deploy Inhibit
6	GND
7	Killswitch override
8	GND
9	Charge-mode only
10	GND

RBF: Remove before flight inhibit (active low). Hardware implemented.

Killswitch override: Overrides killswitch (active high, 5 V). Use to turn on P80 when kill switches are activated.

Deploy Inhibit: Inhibits the deployment power channels V_DEP_1 and V_DEP_2 (active low). Hardware implemented.

Charge-mode only: Instructs the PMU to disable submodules (active low). Used when charging only.

3.4.8 J12 - Flight Preparation Panel (FPP)

Table 3.22: Pinout of PMU J12

Pin	Description	Pin	Description
1	V_CHRG	2	GND
3	V_CHRG	4	GND
5	V_CHRG	6	GND
7	V_CHRG	8	GND
9	V_CHRG	10	GND

V_CHRG Battery charge input (max 10.0 A).

GND System ground.

4 Physical Dimensions

The mechanical dimensions for a standard P80 (1xPMU, 1xACU, 1xPDU) is illustrated in Figure 4.1. Refer to Table 4.1 for physical measurements for all configurations. Note that all dimensions are given in mm.

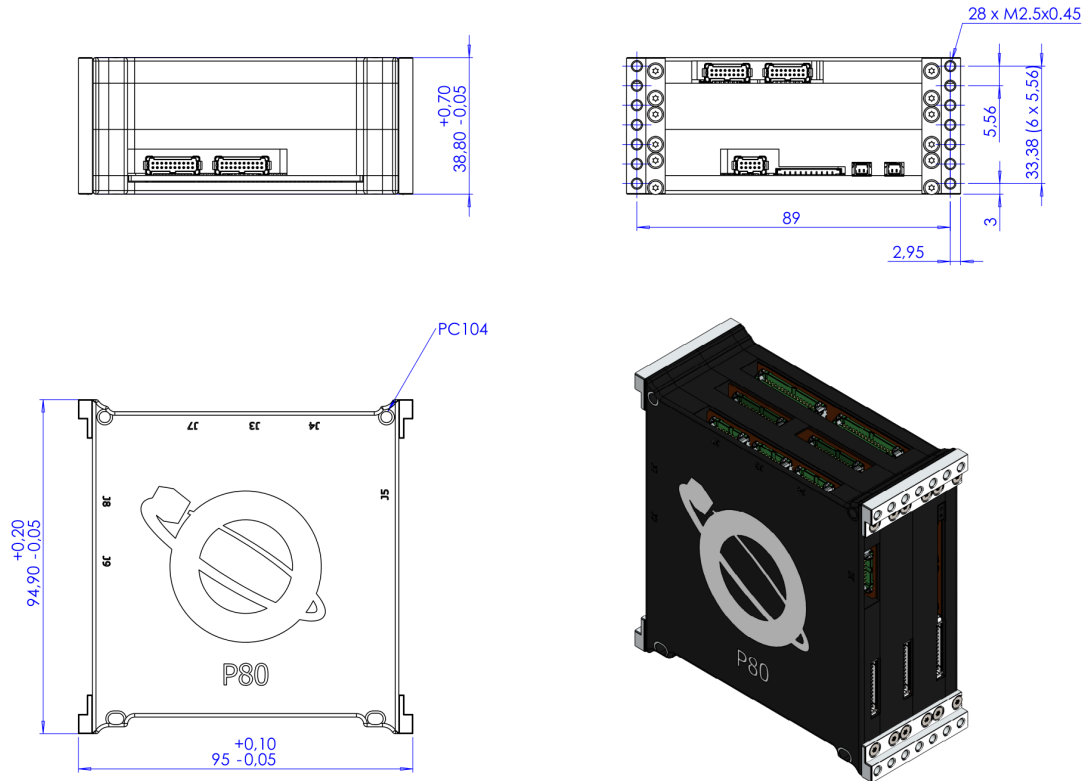

Figure 4.1: Mechanical drawing of the standard P80, 1xPMU 1xACU 1xPDU.

Table 4.1: Physical measurements of the standard P80 configurations.
 Refer to Table 1.1 for configuration names.

Config #	Length [mm]	Width [mm]	Height [mm]	Mass [g]
1	95.0	95.0	38.8	360.8
2	95.0	95.0	51.9	485.5
3	95.0	95.0	65.0	610.2
4	95.0	95.0	51.9	-
5	95.0	95.0	65.0	619.6
6	95.0	95.0	25.7	-
7	95.0	95.0	38.8	-
8	95.0	95.0	51.9	-
9	95.0	95.0	65.0	-

5 References