

# NanoPower TSP-45W

## Datasheet

Document name: NanoPower TSP-45W DataSheet

Document No.: 1038993

Revision: 3.3

Author: RABN

Verified by: FCO

Verification date: 24-04-2024

## Confidentiality Notice

This document is submitted for a specific purpose as agreed in writing and contains information, which is confidential and proprietary. The recipient agrees by accepting this document, that this material will not be used, transferred, reproduced, modified, copied or disclosed in whole or in part, in any manner or to any third party, except own staff to meet the purpose for which it was submitted without prior written consent.

GomSpace © 2024

### CHANGE LOG

Revision	Date	Initials	Description
3.0	01-02-2023	RABN	Major document revision
3.1	09-10-2023	RABN	Corrected HDRM PCB connector designation. Update qualification table.
3.2	25-04-2024	PHK	Deleted Qualification table section 8, as redundant with QTCT
3.3	24-05-2024	LOJE	Updated section 5 (delete note)

# 1. Table of Contents

<b>1.</b>	<b>TABLE OF CONTENTS</b> .....	<b>3</b>
<b>2.</b>	<b>OVERVIEW</b> .....	<b>6</b>
1.1	Highlighted Features.....	8
1.2	Available ordering option .....	9
1.3	Supporting documentation .....	9
<b>3.</b>	<b>WARNINGS</b> .....	<b>10</b>
<b>4.</b>	<b>DETAILED PART DESCRIPTION</b> .....	<b>11</b>
1.1	Solar panel description .....	11
1.1.1	Block diagram – Panel level .....	11
1.1.2	Block diagram – Array level .....	13
1.2	Z-close out covers and connect PCB .....	15
1.2.1	Block diagram - Connect PCB.....	17
1.3	Hold Down Release Mechanism - HDRM .....	19
1.3.1	Release Control PCB Block diagram.....	20
1.3.2	Pinout of Release control PCB .....	21
<b>5.</b>	<b>ABSOLUTE MAXIMUM RATINGS</b> .....	<b>22</b>
1.1	Solar Array performance.....	22
1.2	Release control Board Characteristics .....	22
<b>6.</b>	<b>ELECTRICAL CHARACTERISTICS</b> .....	<b>23</b>
1.1	General grounding diagram .....	23
<b>7.</b>	<b>PHYSICAL CHARACTERISTICS</b> .....	<b>24</b>
<b>8.</b>	<b>DISCLAIMER</b> .....	<b>25</b>
<b>9.</b>	<b>MECHANICAL DRAWINGS</b> .....	<b>26</b>
1.2	Stowed .....	26
1.3	Deployed.....	27
1.4	Mounting to structure .....	27

## List of figures

Figure 2-1: 6U satellite with two deployed NanoPower TSP-45W .....	6
Figure 2-2: Satellite with stowed solar array .....	7
Figure 2-3: Designation of the individual TSP-45W constituents. ....	8
Figure 2-4: Overall block diagram of the power connections of the TSP-45W .....	8
Figure 4-1: Block diagram of Panel .....	11
Figure 4-2: Actual connector placement on panel and pin numbering. ....	12
Figure 4-3: Block diagram of solar array .....	14
Figure 4-4: Solar array connectivity shown on actual geometry. ....	14
Figure 4-5: Designation of Z close out covers. ....	16
Figure 4-6: Physical position of the Connect PCB, FSS, FPP, and GPS. ....	16
Figure 4-7: Left: Bottom view of Connect PCB (interface to EPS and SADA-50) Right: position inside spacecraft .....	17
Figure 4-8: Connect PCB block diagram .....	17
Figure 4-9: Pin numbers for J110 and J111. ....	19
Figure 4-10: Designation of functional parts of HDRM. ....	20
Figure 4-11: <i>Top</i> : HDRM lashed, <i>Bottom</i> : HDRM released. ....	20
Figure 4-12: Release Controller PCB block diagram .....	20
Figure 4-13: Release controller pin numbering .....	21
Figure 6-1 General grounding diagram .....	23
Figure 10-1 Stowed - side view. Protrusion rail shown. The mounting surface is 1mm indented into the cubesat. ....	26
Figure 10-2 Stowed - front view. ....	26
Figure 10-3: Deployed - Top view. ....	27
Figure 10-4: Mounting of cover plate and release device. ....	27
Figure 10-5: Mounting of close out cover. ....	28
Figure 10-6: 8 pcs fixation pins necessary for solar array support for stowed solar array. ....	28

## List of abbreviations

Abbreviation	Explanation
ACU	Array Conditioning Unit
ASD	Acceleration Spectral Density
BOL	Beginning of Life
CTJ	CESI triple junction solar cell
ECSS	European Cooperation for Space Standardization
EPS	Electical Power System
ESCC	European Space Components Coordination
ESD	Electrostatic Discharge
FPP	Flight Preparation Panel
FSS	Fine Sun Sensor
GEVS	General Environmental Verification Standard
GND	Ground
GPS	Global Positioning System
GSSB	GomSpace Signal Bus
HDRM	Hold Down Release Mechanism
LC	Low Cost version of CESI CTJ
NASA	North American Space Agency
PCB	Printed Circuit Board
SAPVPI	Solar Array Photovoltaic ?
SADAPVW	Solar Array Drive AssemblyPhotovoltaic?
SCASA	Solar Cell modelSolar Array
SCLSADA	Serial ClockSolar Array Drive Assembly
SDASCA	Serial DataSolar Cell model
SPSCL	Solar PanelSerial Clock
T <sub>HDRM</sub> SDA	Temperature Hold Down Release Mechanism (HDRM)Serial Data
TIDSP	Total Ionizing DoseSolar Panel
TPT <sub>HDRM</sub>	Test PointTemperature Hold Down Release Mechanism (HDRM)
TSPTID	Tracking Solar PanelsTotal Ionizing Dose
VCCTP	Voltage supplyTest Point
TSP	Tracking Solar Panels
VCC	Voltage supply

## 2. Overview

The NanoPower TSP-45W is a deployable solar array consisting of three panels, each having a 2x3U form factor which makes it integrable on the GomSpace 6U or larger structures. As part of the NanoPower TSP-45W, the SADA-50 enables the sun tracking motion of the solar panels along one body axis. The overall form factor of the product allows two NanoPower TSP-45W products to be mounted on a GomSpace Structure as illustrated in Figure 2-1 on a 6U structure, as an example.

The design consists of a carbon fiber support structure for the slim design and a low mass while maintaining a rigid and strong construction. The wingspan of a single deployed wing is 908 mm when mounted.

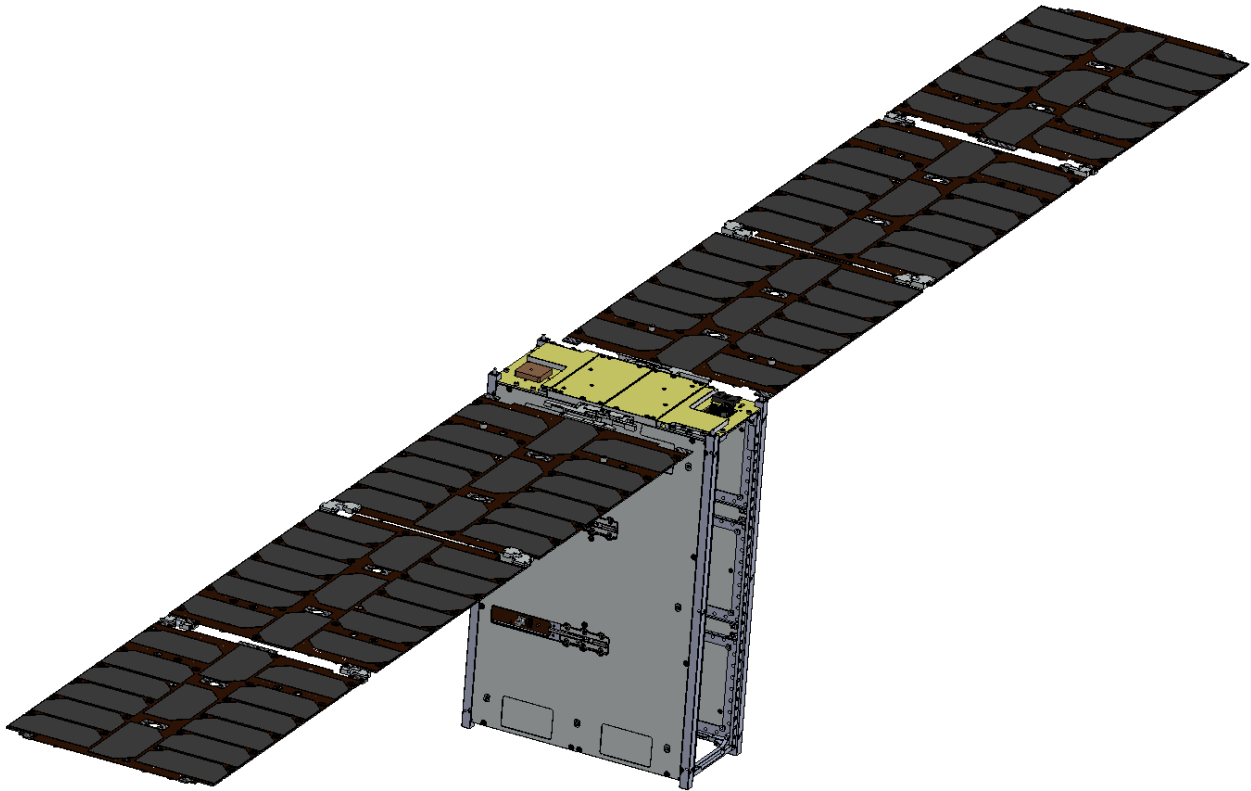

**Figure 2-1: 6U satellite with two deployed NanoPower TSP-45W**

The array stows against the side of the satellite structure during launch and is deployed in orbit – see Figure 2-2. The wing is latched using the Hold Down Release Mechanisms (HDRM) which secures the wing during launch and releases it when commanded. All parts of the HDRM system are also directly integrable on the GomSpace 6U-16U structures portfolio.

While stowed the wing has outwards pointing cells for power production. Each panel holds 15 triple junction solar cells allowing up to 45W power production per wing in nominal conditions (refer to CESI CTJ-LC/SCA-8040 cell datasheet for temperature and aging effect on power generation).

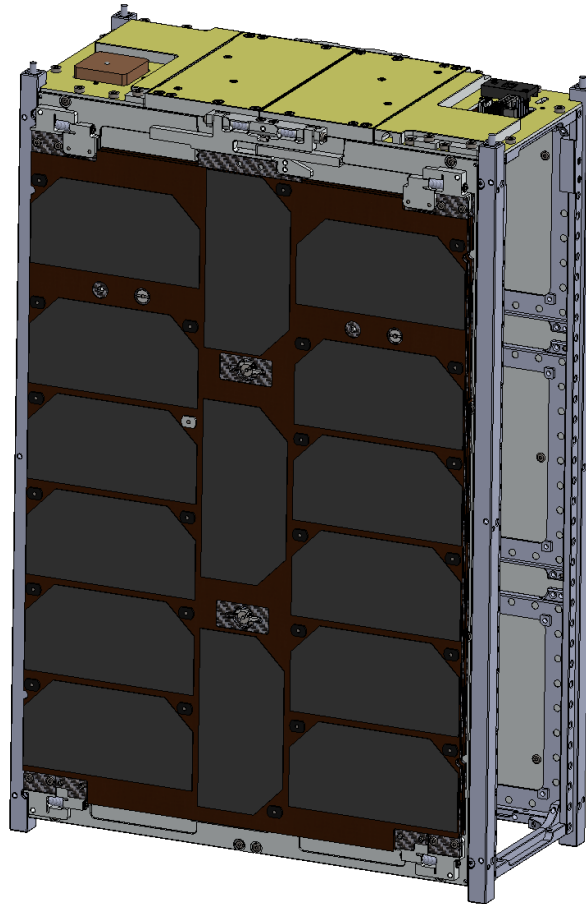

**Figure 2-2: Satellite with stowed solar array**

The product includes the following:

1. Three-panel solar array including:
  - a. Panels
  - b. Cells
  - c. Hinges
  - d. Temperature sensor
  - e. Secondary harnesses for panel-to-panel connection
2. Primary Harness which connects the Solar Array to the Connect PCB
3. SADA-50
4. HDRM: Release Control PCBs and mechanical release devices.
5. Optional and configurable Y-side cover plate for space craft close out, and support and alignment of stowed solar array
6. Z-end cover close out with connect PCB for easy integration and mounting interface for one of the following options:
  - a. Fine Sun Sensor (*FSS*) and Flight Preparation Panel (*FPP*)
  - b. GPS antenna
  - c. Flight Preparation Panel (*FPP*)

Detailed information regarding integration, lashing of HDRMs, software configuration etc, is available in the manuals listed in section 1.3.

An overall block diagram of the TSP-45W (excluding the HDRM parts) is provided in Figure 2-4

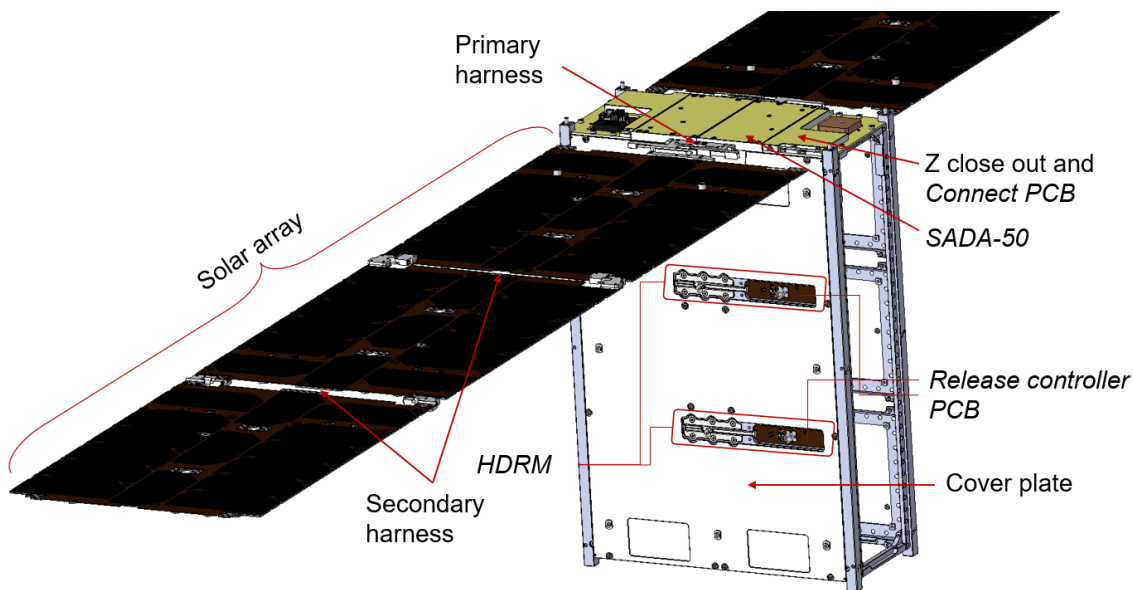

Figure 2-3: Designation of the individual TSP-45W constituents.

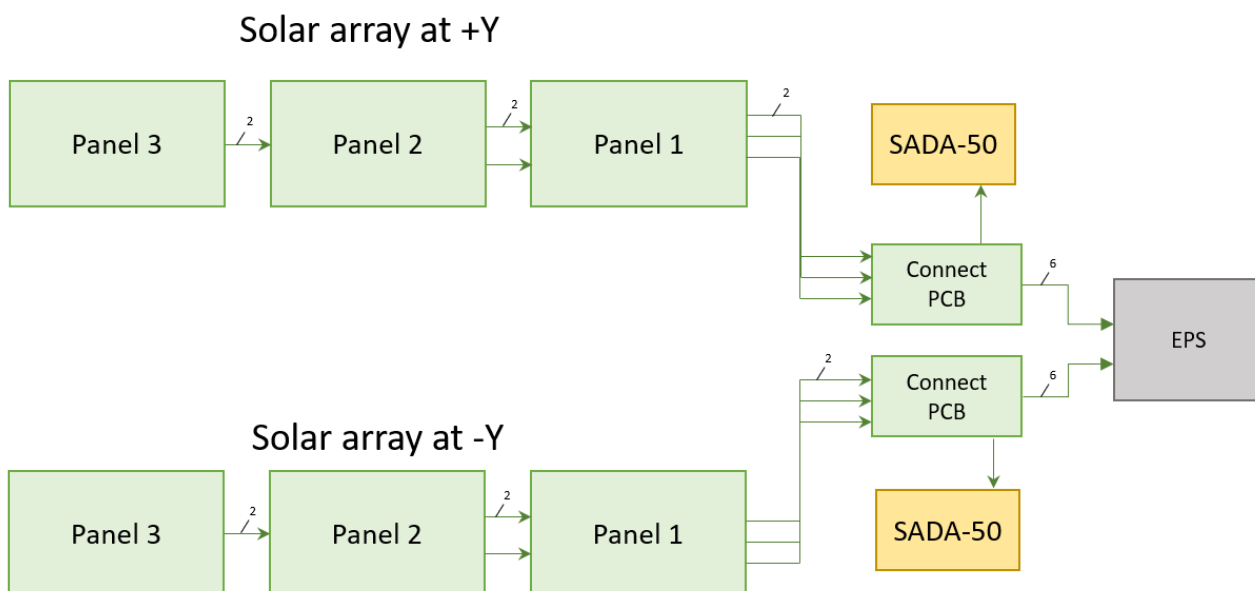

Figure 2-4: Overall block diagram of the power connections of the TSP-45W

### 1.1 Highlighted Features

NanoPower TSP-45W – key features	
<b>Functionality</b>	<ul style="list-style-type: none"> <li>• 15 cells/panel arranged in two strings of 0.5A@16.8V and 0.5A@19.2V, respectively.</li> <li>• Blocking diode on each string (voltage drop 0.85V@25°C)</li> <li>• Bypass diode on each cell</li> <li>• ~1.15 W/cell power production at solar flux of 1367 W/m<sup>2</sup> (BOL and 25°C)</li> <li>• Total power production up to ~45 W/array</li> <li>• Temperature sensor on each wing</li> </ul>



<b>Solar cell</b>	<ul style="list-style-type: none"> <li>• CESI CTJ-LC/SCA-8040</li> <li>• Surface Area: 30.15 cm<sup>2</sup></li> <li>• Efficiency &gt;28% @ AM0, 25°C</li> </ul>
<b>Interfaces</b>	<ul style="list-style-type: none"> <li>• Harwin Gecko connectors for power and data</li> <li>• I<sup>2</sup>C for sensor communication</li> <li>• Pads for release detection available</li> <li>• Interlocking panels in stowed configuration</li> </ul>
<b>Mass and Dimensions</b>	<ul style="list-style-type: none"> <li>• Stowed volume: 330 mm x 208 mm x 9 mm</li> <li>• Deployed length: 930 mm (from rail)</li> <li>• Total mass: 750 g</li> <li>• Deployed mass (i.e., the array): 650 g</li> </ul>

## 1.2 Available ordering option

The options mentioned in Table 1 may be selected independently. When ordering an Option Sheet should be filled out. This could be done in cooperation with GomSpace Sales department.

**Table 1: TSP-45W ordering options.**

Component	Option	Variant
<b>HDRM</b>	Supply voltage	Select between: <b>32 V</b> or <b>5 V</b>
<b>Cover plate</b>	Position of HDRM cut out in cover plate	Select between: <b>Right</b> or <b>Left</b> or <b>None</b> (for no cover plate)
<b>Z close out</b>	Mounting interface for	Select between: <b>FPP+FSS</b> or <b>GPS</b> or <b>FSS</b>

**Important:** The options for the Z-close out only provide the mounting options for the selected components. The components must be ordered separately.

Regarding the cover plate, if the user needs additional customization (e.g., cut outs for star trackers, or similar) a third option is available where the cover plate is not included. In any case the 3D files and mechanical drawings of the cover plate are available on request. In such case it is important to notice that the even a custom cover plate must carry some support parts, to ensure proper fixation of the solar panel when stowed. These are shown in Figure 9-6. Both the fixation pins and mounting screws are included in the even for the no cover plate option.

## 1.3 Supporting documentation

The following documents supporting this datasheet is available:

- NanoPower SADA-50 datasheet
- NanoPower SADA-50 Manual
- NanoPower TSP-45W Manual
- NanoUtil AR6 SW Manual

### 3. Warnings



#### Handling

This product uses advanced solar cells that are fragile. Wear gloves when handling. Do not touch solar cell surface.

**Only handle solar panels without touching solar cells or their tabs**

**Never place anything on the solar cells!**



#### ESD

This product uses semiconductors that can be damaged by electrostatic discharge (ESD). When handling, care must be taken so that the devices are not damaged. Use appropriate precautions.

## 4. Detailed part description

In this section each of the main product components are presented in more detail.

### 1.1 Solar panel description

This section provides more information about the solar panel build up and configurations. In case more information regarding solar cell performance is needed, please see the datasheet for the cell applied.

Each panel consists of 15 solar cells which are configured in strings of 7 and 8 cells, delivering a nominal voltage of 16.8 V and 19.2 V at 0.5 A, respectively.

Each solar string is equipped with a blocking diode in series, to protect partially shaded photovoltaic cells array inside solar panel from the normally operated photovoltaic string if multiple strings are connected in parallel. If multiple strings are connected in parallel, it is important to avoid connecting strings with 7 cells with strings with 8 cells in series. The voltage drop of the blocking diodes are 0.85V@25°C which reduces to about 0.72V@125°C.

All solar cells have a dedicated bypass diode connected in parallel, to ensure that the string is not disconnected in case of a failure of the cell, or if the sunlight is blocked from the spacecraft.

In subsection 1.1.1 the connections on the panel are shown in a bit more detail, and subsection 1.1.2 illustrates how the panel-to-panel connections are arranged. Remark, these details are strictly not necessary since all harness comes pre-installed on the solar array, but just provided for convenience.

#### 1.1.1 Block diagram – Panel level

The diagram in Figure 4-1 a block diagram of a single solar panel with the arrangement of solar panel strings, and feed throughs used for routing through power from neighboring panels, is shown. A temperature sensor is also integrated on the panel closest to the spacecraft, but not shown in the figure for simplicity. Although directional arrows are used in Figure 4-1, the connections are bi-directional electrically.

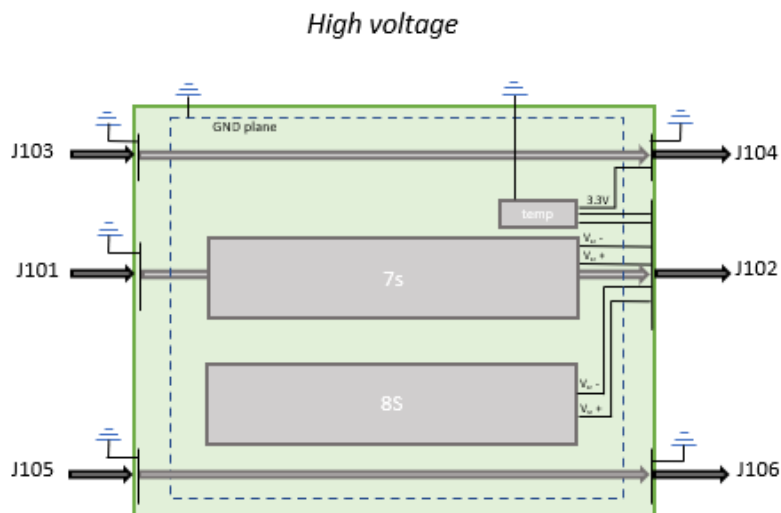

Figure 4-1: Block diagram of Panel

The connectors J101 and J102 are used to connector to the solar cells on the panel itself, whereas the primary functionality of the connections J103 → J104 and J105 → J106 are feed throughs for routing of power from the other panels. The connector type used on panels are *Axon microstrip 6-pin* (Manufacturers part number: P569475).

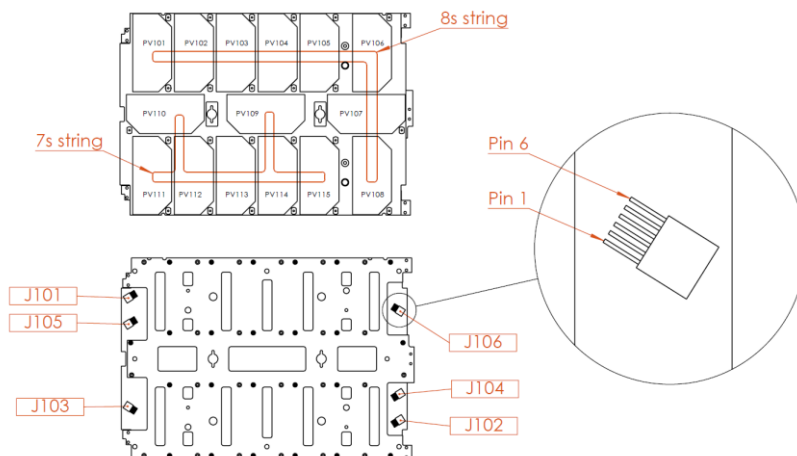

Figure 4-2: Actual connector placement on panel and pin numbering.

**1.1.1.1 Intermediate pinout – Panel level**

The pinout of connectors J101 through J106 are listed below in Table 4-1. Notice that adoption of the terms *positive voltage terminal* ( $V_{sc}$ -positive) and *negative voltage terminal* ( $V_{sc}$ -negative), in place of the terms *cathode* and *anode*.

Table 4-1: Pinout of connectors J101 through J106

J101		
Pin	Name	Connection
1	J101.1	GND
2	J101.2	$V_{sc}$ -positive of 8s string
3	J101.3	$V_{sc}$ -negative of 8s string
4	J101.4	$V_{sc}$ -positive of 7s string
5	J101.5	$V_{sc}$ -negative of 7s string
6	J101.6	GND

J102		
Pin	Name	Connection
1	J102.1	I2C SCL (Pin 1 on Temp sensor)
2	J102.2	$V_{sc}$ -positive of 8s string
3	J102.3	$V_{sc}$ -negative of 8s string
4	J102.4	$V_{sc}$ -positive of 7s string
5	J102.5	$V_{sc}$ -negative of 7s string
6	J102.6	I2C SDA (Pin 6 on Temp sensor)

J103		
Pin	Name	Connection
1	J103.1	GND
2	J103.2	J104.2
3	J103.3	J104.3
4	J103.4	J104.4

<b>5</b>	J103.5	J104.5
<b>6</b>	J103.6	GND

<b>J104</b>		
<b>Pin</b>	<b>Name</b>	<b>Connection</b>
<b>1</b>	J104.1	GND
<b>2</b>	J104.2	J103.2
<b>3</b>	J104.3	J103.3
<b>4</b>	J104.4	J103.4
<b>5</b>	J104.5	J103.5
<b>6</b>	J104.6	3.3V (For temp sensor)

<b>J105</b>		
<b>1</b>	J105.1	GND
<b>2</b>	J105.2	J106.2
<b>3</b>	J105.3	J106.3
<b>4</b>	J105.4	J106.4
<b>5</b>	J105.5	J106.5
<b>6</b>	J105.6	GND

<b>J106</b>		
<b>Pin</b>	<b>Name</b>	<b>Connection</b>
<b>1</b>	J106.1	GND
<b>2</b>	J106.2	J105.2
<b>3</b>	J106.3	J105.3
<b>4</b>	J106.4	J105.4
<b>5</b>	J106.5	J105.5
<b>6</b>	J106.6	GND

### 1.1.2 Block diagram – Array level

Figure 4-3 illustrates how the 3 panels of the solar array is mutually interconnected. Remark that all three panels are identical, but *Panel 2* (the center panel) has the PCB reversed on the panel backplate compared with *Panel 1* and *Panel 3*. An illustration of the array interconnections shown on the actual geometry is found in Figure 4-4.

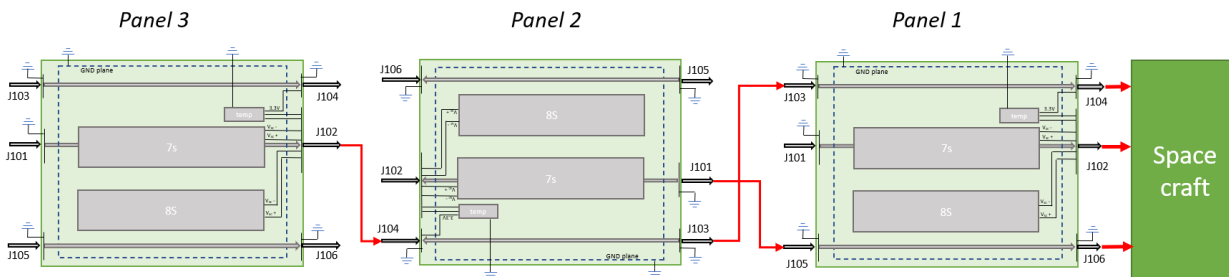

Figure 4-3: Block diagram of solar array

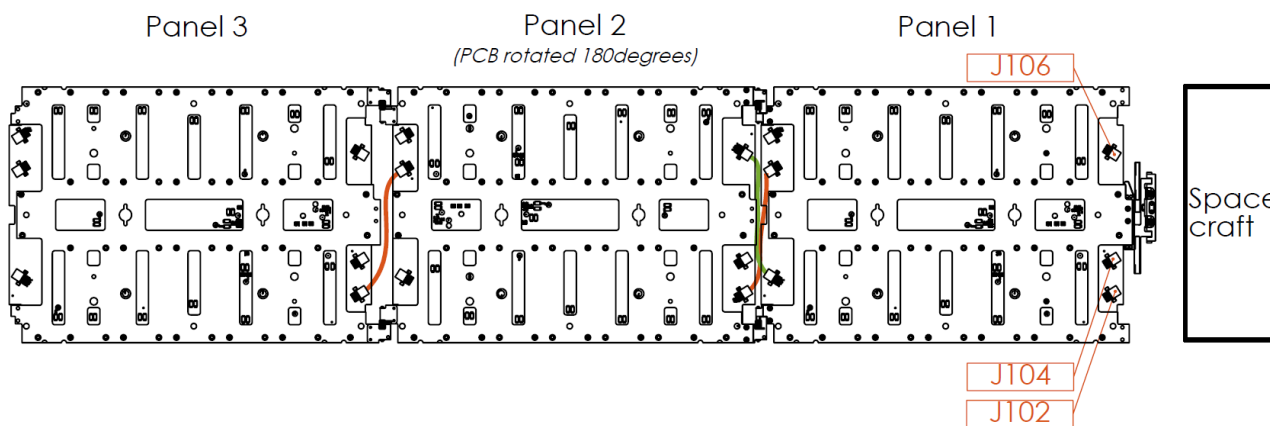

Figure 4-4: Solar array connectivity shown on actual geometry.

1.1.2.1 Intermediate pinout – array level

The corresponding pinout of the connectors J102, J104, and J106 on panel 1 is provided in Table 2. This pinout is for reference only the, as the final interface point for the product is the connect PCB.

Table 2: Pinout at array level before connect PCB

J102 (on panel 1)		
Pin	Name	Connection
1	J102.1	I2C_SCL (Temp sensor)
2	J102.2	$V_{sc}$ -positive: 8s string of <b>Panel 1</b>
3	J102.3	$V_{sc}$ -negative: 8s string of <b>Panel 1</b>
4	J102.4	$V_{sc}$ -positive: 7s string of <b>Panel 1</b>
5	J102.5	$V_{sc}$ -negative: 7s string of <b>Panel 1</b>
6	J102.6	I2C_SDA (Temp sensor)
J104 (on panel 1)		
Pin	Name	Connection
1	J104.1	GND
2	J104.2	$V_{sc}$ -positive: 8s string of <b>Panel 3</b>
3	J104.3	$V_{sc}$ -negative: 8s string of <b>Panel 3</b>
4	J104.4	$V_{sc}$ -positive: 7s string of <b>Panel 3</b>
5	J104.5	$V_{sc}$ -negative: 7s string of <b>Panel 3</b>

<b>6</b>	J104.6	3.3V (Temp sensor)
<b>J106 (on panel 1)</b>		
<b>Pin</b>	<b>Name</b>	<b>Connection</b>
<b>1</b>	J106.1	GND
<b>2</b>	J106.2	<i>V<sub>sc-positive</sub>: 8s string of <b>Panel 2</b></i>
<b>3</b>	J106.3	<i>V<sub>sc-negative</sub>: 8s string of <b>Panel 2</b></i>
<b>4</b>	J106.4	<i>V<sub>sc-positive</sub>: 7s string of <b>Panel 2</b></i>
<b>5</b>	J106.5	<i>V<sub>sc-negative</sub>: 7s string of <b>Panel 2</b></i>
<b>6</b>	J106.6	GND

## 1.2 Z-close out covers and connect PCB

The Z-close out cover consists of the *Z bottom cover* and the *Z top cover* shown in Figure 4-5. The various ordering options for *Z-close out* allows for placing GPS antennas, Fine Sun Sensors (FSS), and a Flight Preparation Panel (FPP) next to the SADA-50 and connect PCB. These options are exemplified in Figure 4-6.

The connect PCB is basically just a pass-through board between the pre-integrated solar array harness (on the outside of the satellite) and the harness to the power supply (on the inside of spacecraft). The position of the connect PCB is also shown in Figure 9-6. It is emphasized that the harness from the connect PCB the power supply is not included.

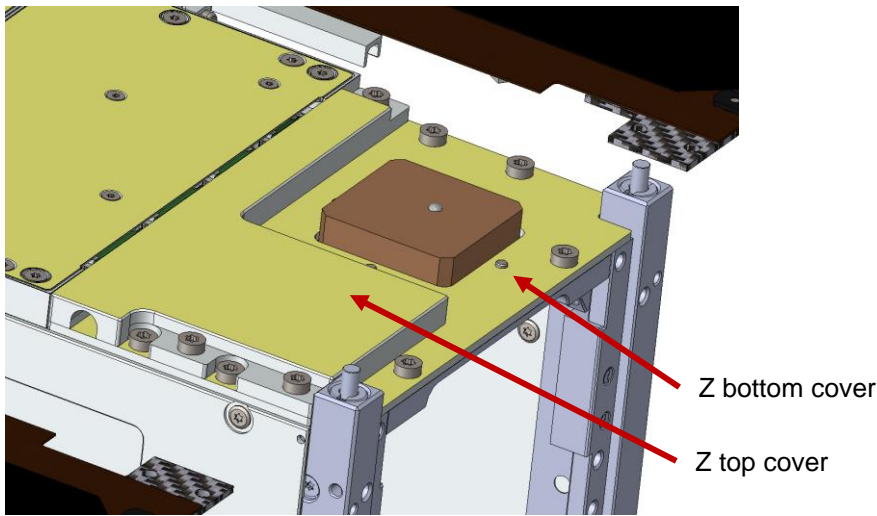

Figure 4-5: Designation of Z close out covers.

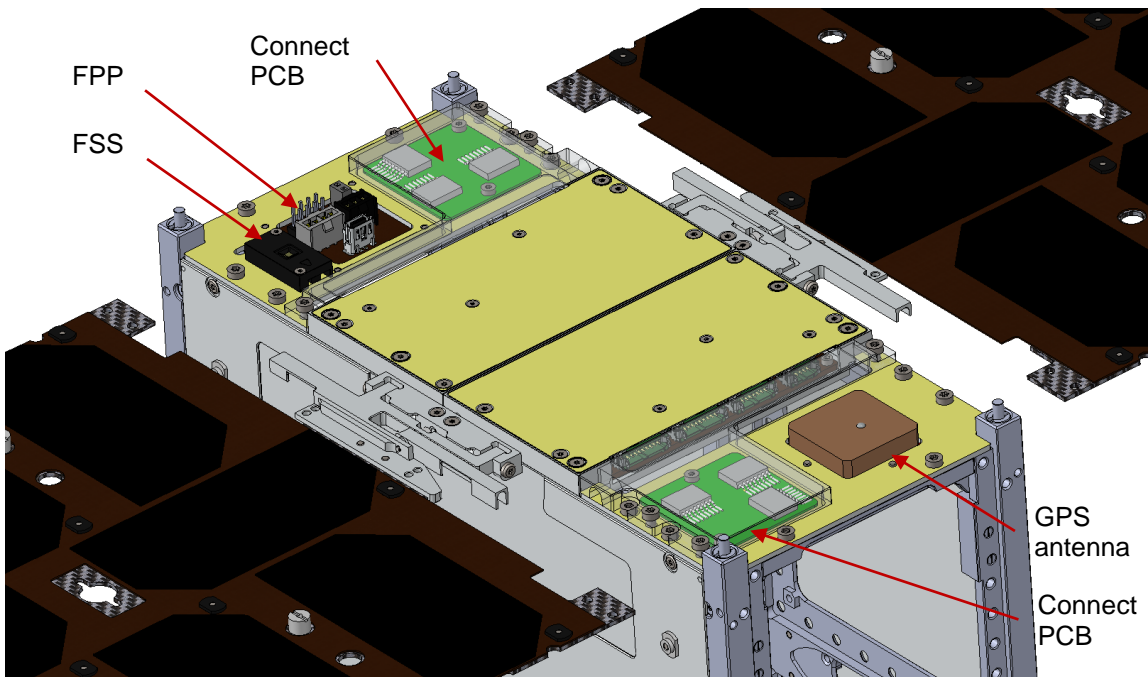

Figure 4-6: Physical position of the Connect PCB, FSS, FPP, and GPS.

The bottom of the connect PCB, see Figure 4-7, is equipped with a 10-pin Harwin Gecko G125-FS11005L0R connector (J111) which is used for telemetry (from the temperature sensor) from the solar array to the SADA-50, and a 26-pin Harwin Gecko G125-FS12605L0P connector (J110) that delivers power to the EPS. The option for using the array temperature sensor is completely voluntary and for that reason harness between J111 and the SADA-50 is not included.



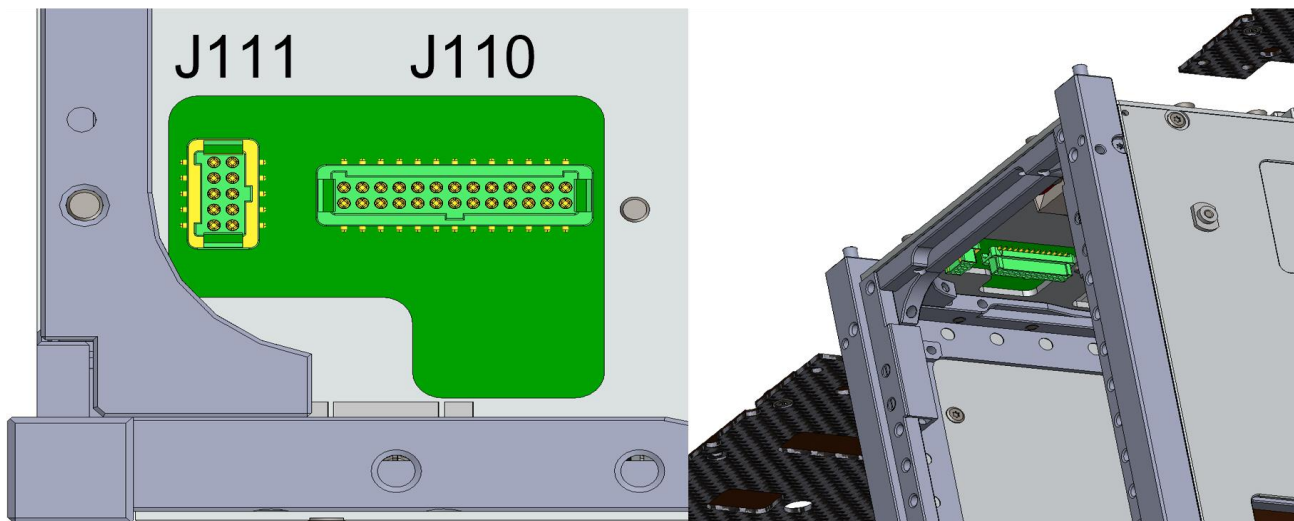

Figure 4-7: Left: Bottom view of Connect PCB (interface to EPS and SADA-50) Right: position inside spacecraft

### 1.2.1 Block diagram - Connect PCB

A block diagram of the Connect PCB is shown in Figure 4-8. The voltage from the 3 solar panels is present at the three connectors J102, J104 and J106. Connections are then routed through the connect PCB to J110 which is the final interface point to the satellite EPS. On the connect PCB all  $V_{sc}$  – negative are connected to a common GND. The I<sup>2</sup>C communication lines of the temperature sensor on the solar panel are connected from J102 to J111. The supply voltage for the temperature sensor is connected from J104 to J111.

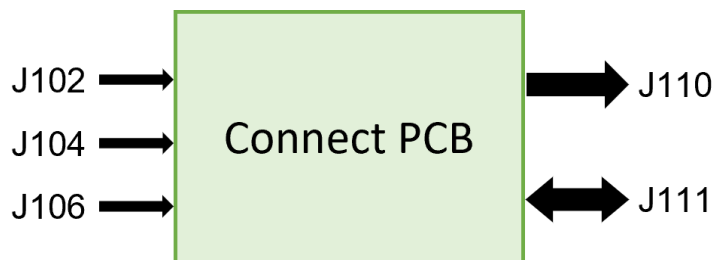

Figure 4-8: Connect PCB block diagram

#### 1.2.1.1 Final Pinout – Connect PCB

The primary harness which is pre-mounted on the solar array shall be connected to the connect PCB during integration. The connectors on the primary harness are labelled J102, J104, and J106, and shall be connected to J102, J104, and J106, respectively on the connect PCB. Detailed instructions are available in the manual. Pinouts of J110 and J111 are provided in Table 4-3 and Table 4-4, and the pin numbers are provided in Figure 4-9.

Table 4-3: Pinout of J110.  
 Harwin Gecko - G125-FS12605L0P

Pin	String and panel designation
1	$V_{sc}$ -positive: 8s string of <b>Panel 1</b> (J102.2)
2	
3	GND
4	
5	$V_{sc}$ -positive: 7s string of <b>Panel 1</b> (J102.4)
6	

7	GND
8	
9	<i>V<sub>sc</sub>-positive: 8s string of <b>Panel 3</b> (J104.2)</i>
10	
11	GND
12	
13	<i>V<sub>sc</sub>-positive: 7s string of <b>Panel 3</b> (J104.4)</i>
14	
15	GND
16	
17	<i>V<sub>sc</sub>-positive: 8s string of <b>Panel 2</b> (J106.2)</i>
18	
19	GND
20	
21	<i>V<sub>sc</sub>-positive: 7s string of <b>Panel 2</b> (J106.4)</i>
22	
23	GND
24	
25	GND
26	

**Table 4-4: Pinout of J111**  
**Harwin Gecko - G125- FS11005L0R**

Pin	Name	Connection
1	GND	GND
2	GND	GND
3	PVPI_GSSB_I2C_SCL	Pin 1 on J102
4	PVPI_GSSB_I2C_SCL	Pin 1 on J102
5	VCC_PVW (3.3V)	Pin 6 on J104
6	VCC_PVW (3.3V)	Pin 6 on J104
7	PVPI_GSSB_I2C_SDA	Pin 6 on J102
8	PVPI_GSSB_I2C_SDA	Pin 6 on J102
9	GND	GND
10	GND	GND

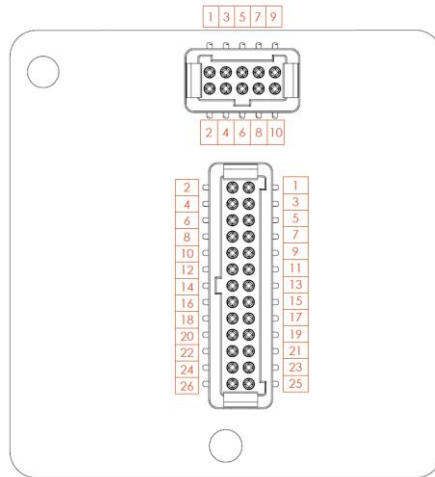

**Figure 4-9: Pin numbers for J110 and J111.**

### 1.3 Hold Down Release Mechanism - HDRM

The *Hold Down and Release Devices* (HDRM) are based on a burn wire principle, where the sleigh of the mechanical release device is lashed with a burn wire, which runs over two burn resistors, and is locked below a clamp plate. The burn wire can be ruptured by activation of the resistors, which allows the sleigh to move sideways and release the solar array. In Figure 4-10 the HDRM is shown with designations of various functional parts, and in Figure 4-11, the HDRM is shown in locked and in release state.

For more details of the functional principles of the release controller PCB, available telemetry etc, please see the NanoUtil AR6 SW Manual.

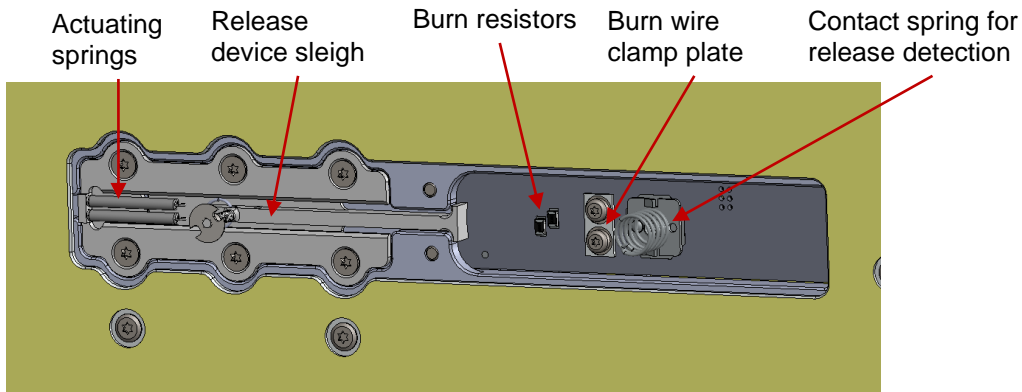

Figure 4-10: Designation of functional parts of HDRM.

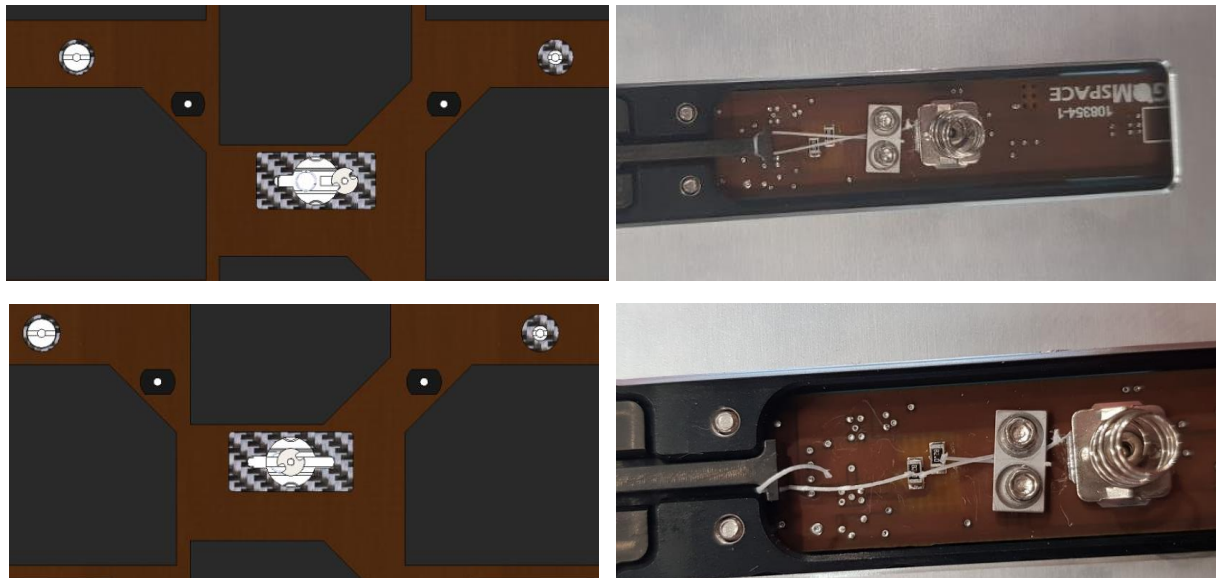

Figure 4-11: *Top*: HDRM lashed, *Bottom*: HDRM released.

Two HDRM devices are used for each solar array and are integrated directly in the GomSpace structure as seen in Figure 2-3. The contact spring, shown in Figure 4-10, is in contact with GND on the first solar panel and thereby detects if the solar array has release successfully.

### 1.3.1 Release Control PCB Block diagram

The block diagram for the of the Release Control PCB is shown in Figure 4-12. Two separate power connections are required as shown in Figure 4-13, i.e. supply voltage for the Release Controller PCB itself, and supply

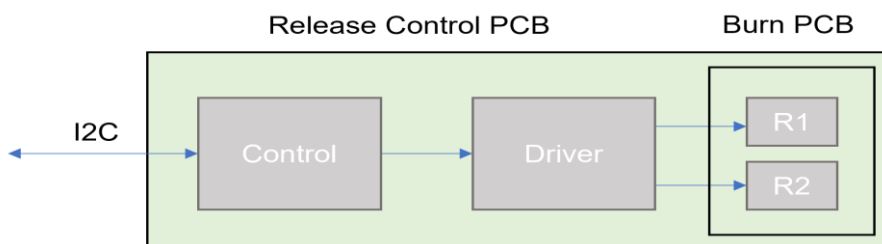

Figure 4-12: Release Controller PCB block diagram

voltage for the burn resistors. Several Release Control PCBs may be daisy chained by the connectors *J1* and *J2* (see section 1.3.2).

**1.3.1.1 Cross burn (Redundancy feature)**

For redundancy purposes an optional *cross burn functionality* is included in the Release Control PCB. This is found in connect *J3* (see section 1.3.2). By connecting *J3* from one Release Controller PCB to *J3* on another Release Control PCB it is possible to do a burn on one Release Control PCB, using the control and driver on the other Release Control PCB, and vice versa.

**1.3.2 Pinout of Release control PCB**

Connectors *J1* and *J2* are connected and carry the burn signal to the resistors as well as data and supply lines. *J3* is used for cross burn functionality.

**IMPORTANT:** Note that the *J1*/*J2* pins are flipped, and extra care must be paid to polarity!

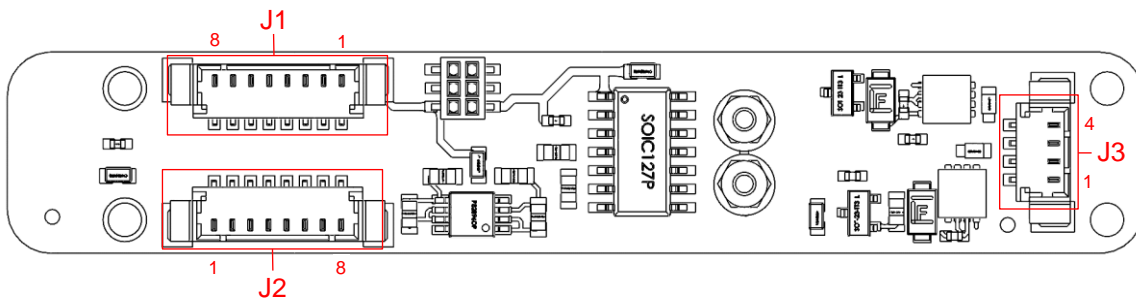

Figure 4-13: Release controller pin numbering

Table 5: Release controller pinout.

J1			J2			J3		
Pin	Name	Connection	Pin	Name	Connection	Pin	Name	Connection
1	GSSB_SDA	SDA	1	GND	GND	1	GND	GND
2	GSSB_SCK	SCK	2	GND	GND	2	B1_OUT	cross burn
3	GSSB_VCC	GSSB_VCC	3	BURN_B1	V_Burn	3	B1_OUT	cross burn
4	GND	GND	4	BURN_B1	V_Burn	4	GND	GND
5	BURN_B1	V_Burn	5	GND	GND			
6	BURN_B1	V_Burn	6	GSSB_VCC	GSSB_VCC			
7	GND	GND	7	GSSD_SCK	SCK			
8	GND	GND	8	GSSB_SDA	SDA			

## 5. Absolute Maximum Ratings

Stresses above those listed under Absolute Maximum Rating may cause permanent damage to the TSP. Exposure to absolute maximum rating conditions for extended periods may affect reliability.

	Description	Min.	Max.	Unit
<b>T<sub>operation</sub></b>	Operating Temperature on the panels that are deployed	-101	+101	°C
<b>T<sub>HDRM</sub></b>	Temperatures during usage of HDRM device.	-40	80	°C

### 1.1 Solar Array performance

The following table gives an overview of some key parameters of the solar cells. More specific information can be found in the datasheets, if required.

	Description	Min.	Typ.	Max.	Unit
<b>CESI cells</b>	String current	0.49	0.50	0.510	A
<b>CESI cells loaded</b>	String voltage 7 cells		15.82		V
	String voltage 8 cells		18.08		V
<b>CESI cells open circuit</b>	String voltage 7 cells		18.20		V
	String voltage 8 cells		20.80		V

### 1.2 Release control Board Characteristics

Numbers are provided for a single Release Control PCB

	Description	Min.	Typ.	Max.	Unit
<b>Release current (5V)</b>	Supply current		650		mA
<b>Release Voltage (5V)*</b>	Release Voltage 5V		5		V
<b>Release current (32V)</b>	Supply current	78	96	104	mA
<b>Release Voltage (32V)</b>	Release Voltage 32V	26	32	33.2	V

\*The 5V release bus is always a regulated voltage at Gomspace, and for that reason min/max is not specified.

## 6. Electrical Characteristics

### 1.1 General grounding diagram

A general grounding diagram of the NanoPower TSP-45W is shown below in Figure 6-1. Bonding impedances shown in the diagram may be provided upon request.

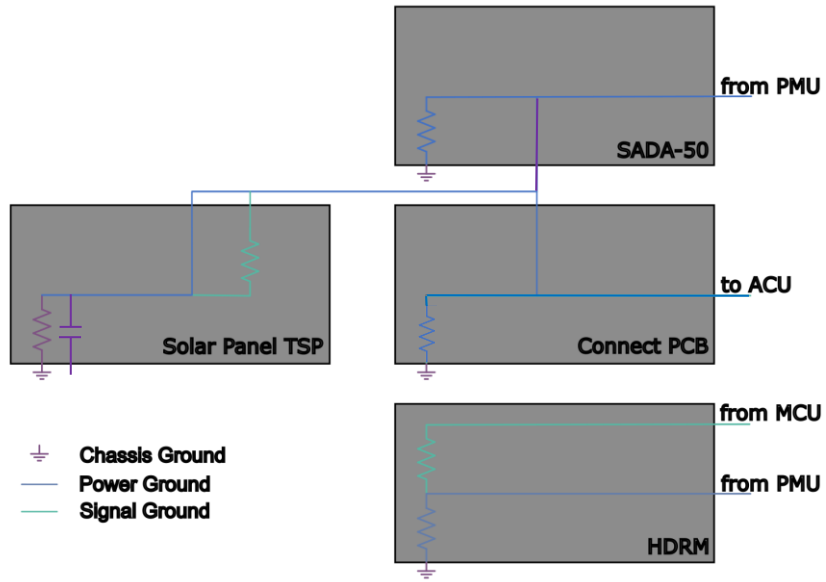

Figure 6-1 General grounding diagram

## 7. Physical Characteristics

Description	Value	Unit
<b>Total Mass</b>	885	g
<b>Mass breakdown</b>	Deployed mass (i.e., the array): 650g HDRM parts: 30g Cover plate: 165 g Z cover close out parts: 40g	G
<b>Size</b>	<i>View Mechanical drawings in section 9</i>	



## 8. Disclaimer

The information in this document is subject to change without notice and should not be construed as a commitment by GomSpace. GomSpace assumes no responsibility for any errors that may appear in this document.

In no event shall GomSpace be liable for incidental or consequential damages arising from use of this document or the software and hardware described in this document.

## 9. Mechanical Drawings

All dimensions in mm.

### 1.2 Stowed

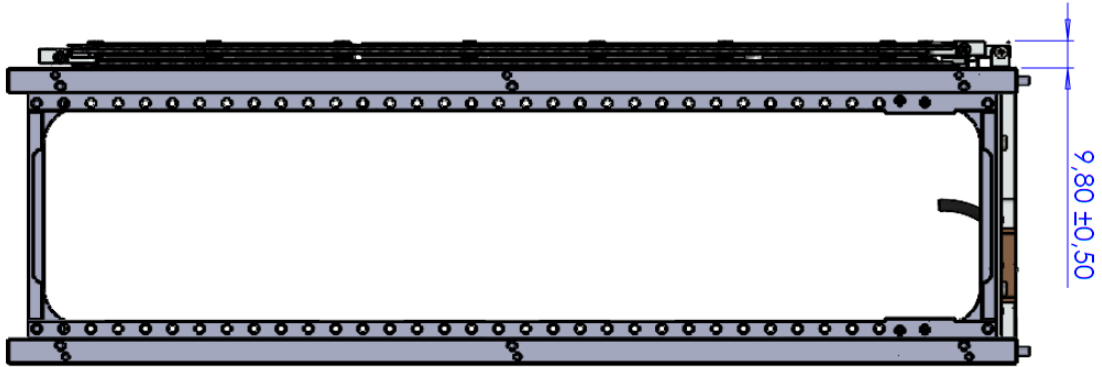

Figure 9-1 Stowed - side view. Protrusion rail shown. The mounting surface is 1mm indented into the cubesat.

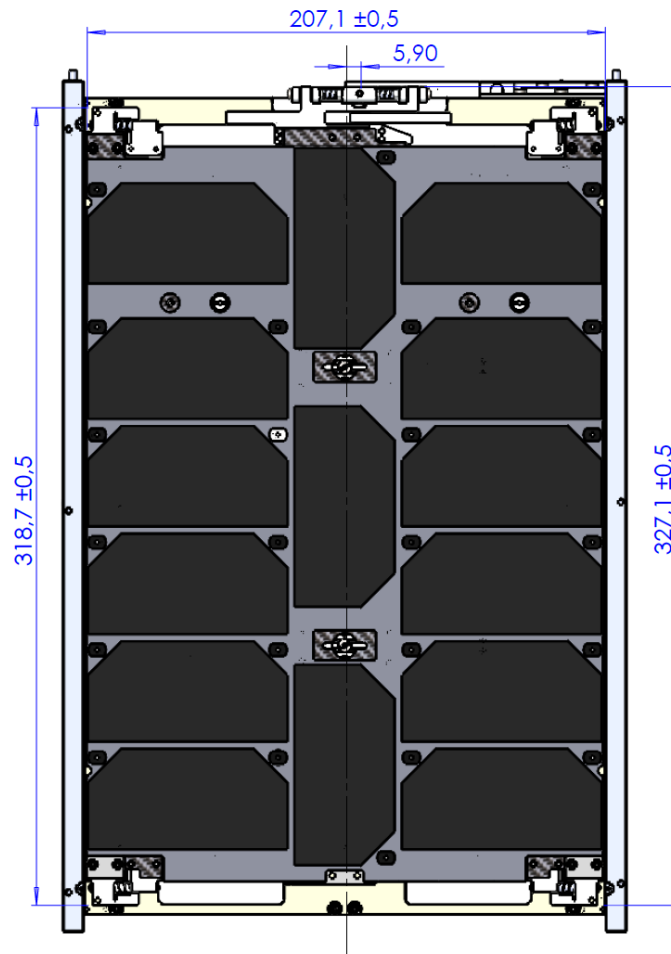

Figure 9-2 Stowed - front view

### 1.3 Deployed

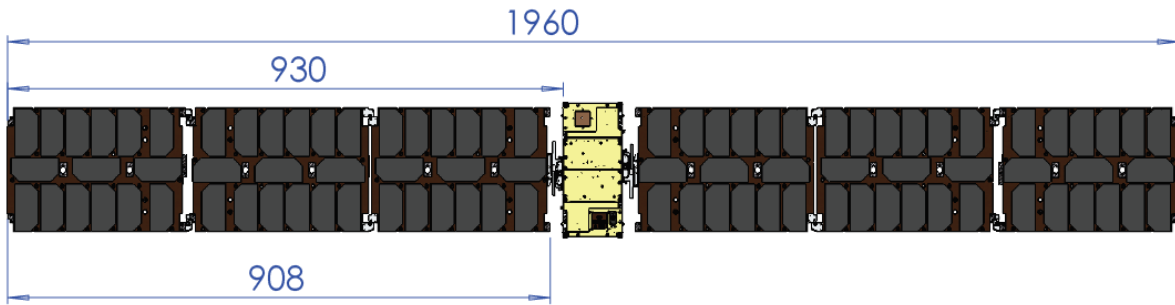

Figure 9-3: Deployed - Top view.

### 1.4 Mounting to structure

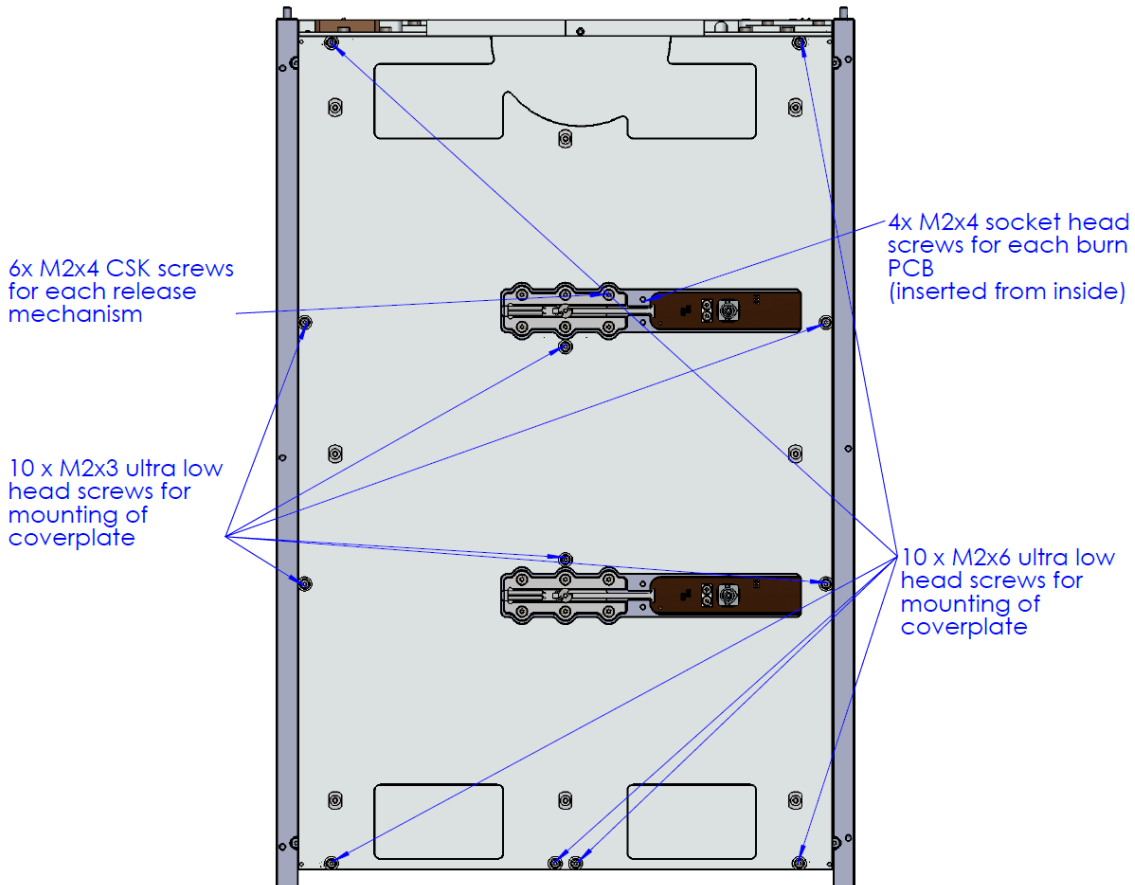

Figure 9-4: Mounting of cover plate and release device.

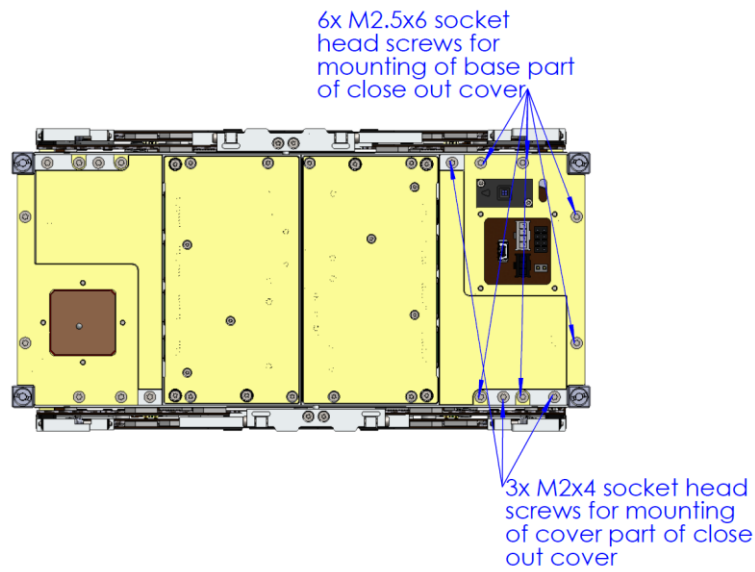

Figure 9-5: Mounting of close out cover.

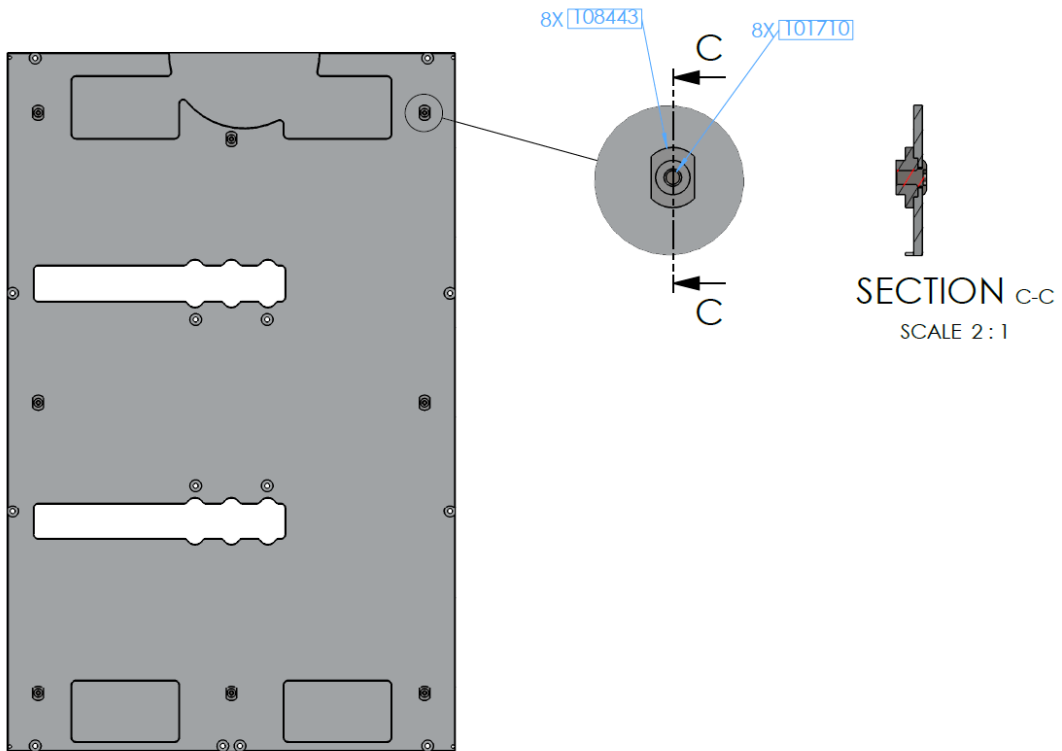

Figure 9-6: 8 pcs fixation pins necessary for solar array support for stowed solar array.