



NanoCam C1U

Datasheet

Camera payload for nano-satellites

Product name: NanoCam C1U

Document No.: 1010105

Revision:1.8

Author:KLK

Approved by: LMR

Approval date: 12 July 2018

Confidentiality Notice

This document is submitted for a specific purpose as agreed in writing and contains information which is confidential and proprietary. The recipient agrees by accepting this document, that this material will not be used, transferred, reproduced, modified, copied or disclosed in whole or in part, in any manner or to any third party, except own staff to meet the purpose for which it was submitted without prior written consent.

GomSpace © 2018

1 Table of Contents

1	Table of Contents	3
2	Overview	4
	2.1 HIGHLIGHTED FEATURES	4
	2.2 CONFIGURATION	5
	2.3 LENS TABLE	5
	2.4 BLOCK DIAGRAM	6
	2.4.1 Processor	6
	2.4.2 Storage	7
	2.4.3 Image sensor.....	7
	2.4.4 F-RAM & RTC	7
	2.4.5 Interfaces.....	7
	2.4.6 GOSH.....	7
	2.4.7 Sensors	7
	2.5 LENSES	8
3	Hardware Layout	9
	3.1 J1: USB CONNECTOR.....	9
	3.2 J2: GOSH CONNECTOR.....	10
	3.3 J3: MAIN CONNECTOR	10
4	Data Interface	11
	4.1 CAN	11
	4.2 I²C	11
	4.3 RS-422.....	11
	4.4 SERIAL PORT.....	11
5	Absolute Maximum Ratings	12
6	Electrical Characteristics	12
	6.1 POWER USAGE	12
7	Physical Characteristics.....	12
8	Mechanical Drawing	13
	8.1 70 MM	13
	8.2 35 MM - 1U VERSION	14

2 Overview

The NanoCam C1U system is a flexible and modular system to rapidly implement tailored imaging systems based on customer requirements. It is an off-the-shelf configuration consisting of: lens, lens table, image acquisition, processing board, and software.

NanoCam C1U has been designed to be implementable in a standard 1U CubeSat structure together with GomSpace's on-board computers, attitude control system, radio transceiver and power products to allow low cost Earth observation using CubeSats.

This is the new upgraded version of the GomSpace NanoCam C1U, with upgraded image processing capabilities.

2.1 Highlighted Features

Integrated System:

- Industrial Lens
- 3-megapixel color sensor
- Capable data processing and storage on-board

Image Acquisition:

- 1/2" (4:3) format color CMOS sensor
- 2048 x 1536 pixels
- 10-bit RRGB Bayer pattern

Lens Performance:

- Three high-end industrial lenses
 - 8 mm f/1.4
 - 35 mm f/1.9
 - 70 mm f/2.2
- 8 mm lens: <260 m/pixel from 650 km
- 35 mm lens: <60 m/pixel from 650 km
- 70 mm lens: <30 m/pixel from 650 km
- 400-750 nm spectral transmission

Data Processing:

- High-performance ARM processor
- 512 MB on-board DDR2 RAM
- 2 GB solid state image storage
- RAW, BMP and JPEG output formats

Interface:

- CSP-enabled CAN, I²C, RS-422 and TTL level serial interfaces
- Serial port with text-based console

Quality:

- Glass/Polyimide IPC 6012C cl. 3/A
- IPC-A-610 Class 3 assembly

2.2 Configuration

The C1U is based on an industrial compact C-mount optical system from Schneider Optics. The lens mounts in the lens table, which is the main load bearing part of the system. The image sensor is located at the topside of the camera printed circuit board, beneath the lens table and interfaces to the image processor and memory components on the bottom side of the board. A heat and EMI shield covers the bottom side of the camera PCB.

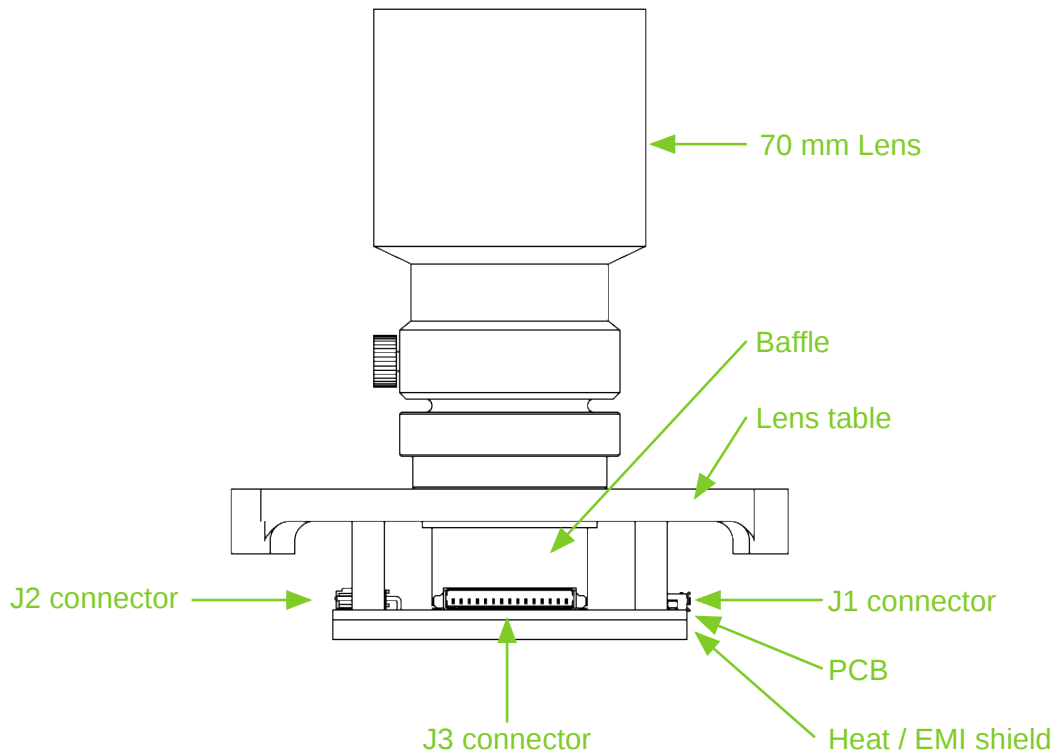

2.3 Lens Table

The lens table can be mounted either pointing up or down (like in the drawing above). It is per default mounted pointing down, except if it is to be mounted in a 1U satellite.

2.4 Block Diagram

Figure 1 shows a block diagram of the main hardware components in the NanoCam C1U.

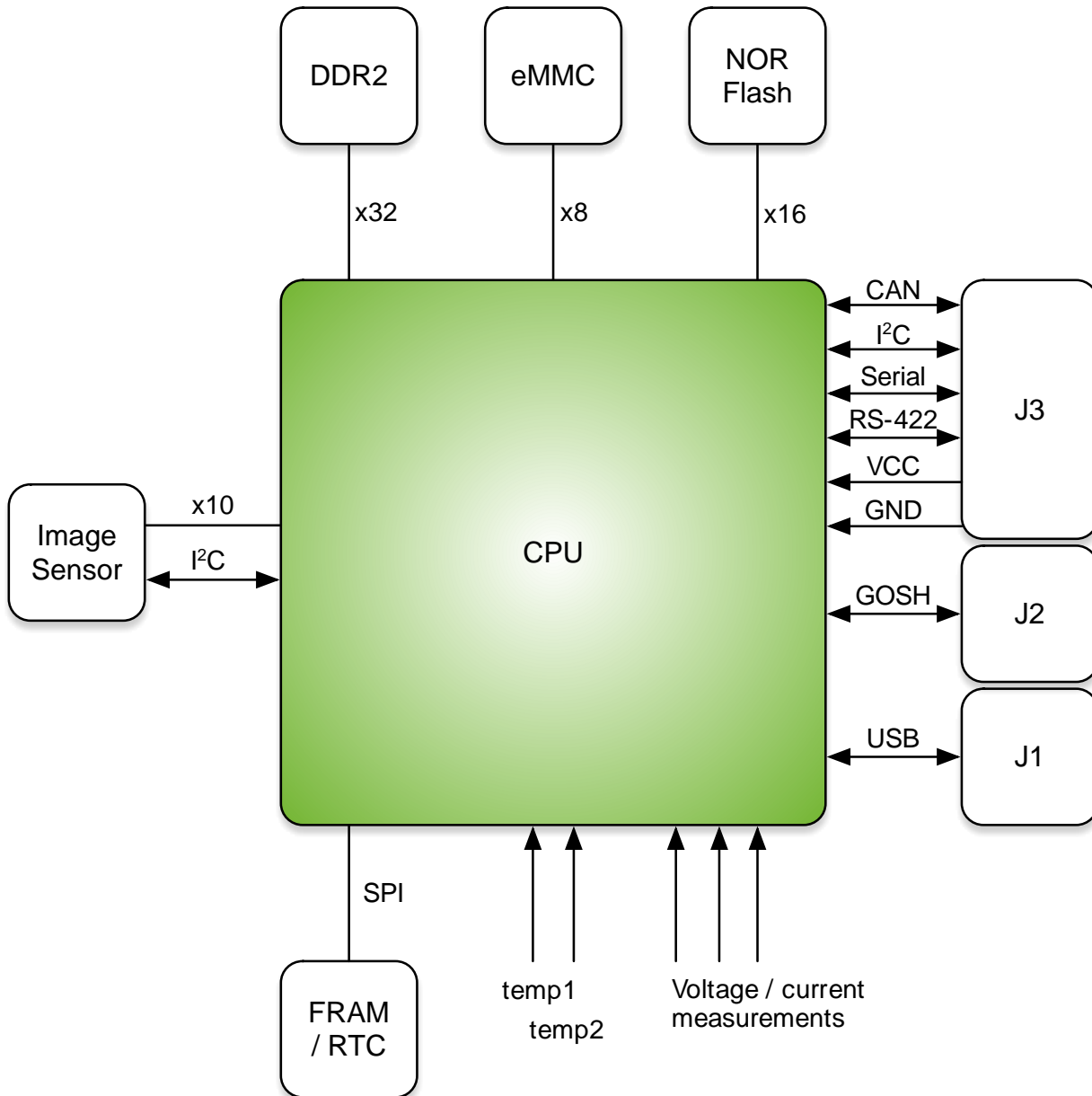

Figure 1 Block diagram for the C1U.

2.4.1 Processor

The NanoCam C1U is based on an Atmel SAMA5D35 processor. This is a high-performance, power-efficient ARM Cortex-A5 CPU with integrated floating-point unit. The NanoCam application runs on a customized embedded Linux platform (GomSpace Linux).

2.4.2 Storage

The board includes 512 MB DDR2 memory for image storage and processing. A 4 GB eMMC flash is used for the root file system and for persistent storage of captured images. 2 GB of the flash is available for image storage. The system boots from a dedicated 64 MB NOR flash attached to the processors external bus interface.

2.4.3 Image sensor

A key component of the NanoCam is the Aptina MT9T031 digital image sensor. This 1/2" CMOS sensor produces color images up to 2048x1536 pixels resolution with 10-bit per pixel ADC resolution. It is connected to the main processor with a 10-bit parallel interface for data and I²C for control of image parameters.

2.4.4 F-RAM & RTC

For storage of non-volatile configuration and telemetry data, the C1U board includes a 32 kB Ferroelectric RAM (F-RAM) from Cypress Semiconductor. The stored data is accessible through the GomSpace parameter system. The F-RAM provides virtually unlimited write-erase cycles and also includes a built-in capacitor-backed Real-Time Clock (RTC) that is used to maintain system time across reboots and short periods without power.

2.4.5 Interfaces

The camera is controlled using the Cubesat Space Protocol (CSP) via CAN, I²C, RS-422 or TTL level serial port. Multiple interfaces can be enabled simultaneously to use different interfaces to communicate with different subsystems on the satellite bus.

2.4.6 GOSH

A serial console provides access to operation and debugging commands through the GomSpace shell (GOSH). The serial console also allows access to the standard Linux shell.

2.4.7 Sensors

The NanoCam includes two analog temperature sensors, plus voltage and current sensors on the 3.3 V (VCC), 1.8 V (DDR2) and 1.2 V (CPU) power rails. These values can be read through the parameter system.

2.5 Lenses

The C1U is designed to accommodate any lens that conforms to the C-mount interface. It has been tested with the Schneider Optics Industrial Ruggedized 2/3" format lenses. The following features apply to all these lenses:

- 2/3" format
- 11 mm image circle
- 400-750 nm pass band
- Corrected and broadband coated
- Robust metal body
- Precise focusing via fine internal thread
- Unique, robust focus lock
- Click-stop free iris setting / Iris lock
- Integrated front thread to accept SN2 mount filters

The C1U is supplied with a (removable) Schneider Kreuznach BP 540-300 (486) HT UV/IR cut filter, that blocks UV light below 390 nm and IR above 690 nm. Other filter options are available on request.

The following standard lenses from Schneider Optics have been tested with the C1U:

Cinegon 1.4/8-0902

F-number: 1.4
Focal length: 8,2 mm
Length from flange: 32.4 mm
Filter thread: M30.5x0.5
Mass: 90 g

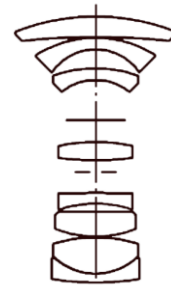

XENOPLAN 1.9/35MM COMPACT

F-number: 1.9
Focal length: 34.9 mm
Length from flange: 34.7 mm
Filter thread: M30.5x0.5
Mass: 92 g

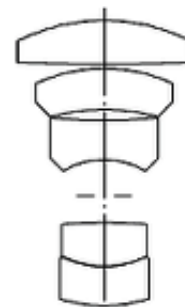

TELE-XENAR 2.2/70MM COMPACT

F-number: 2.2
Focal length: 70.5 mm
Length from flange: 74.0 mm
Filter thread: M40.5x0.5
Mass: 200 g

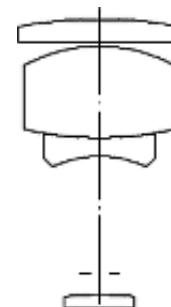

3 Hardware Layout

The NanoCam C1U has three connectors on the topside of the PCB, labeled J1, J2, and J3. The connector locations are highlighted in the figure below.

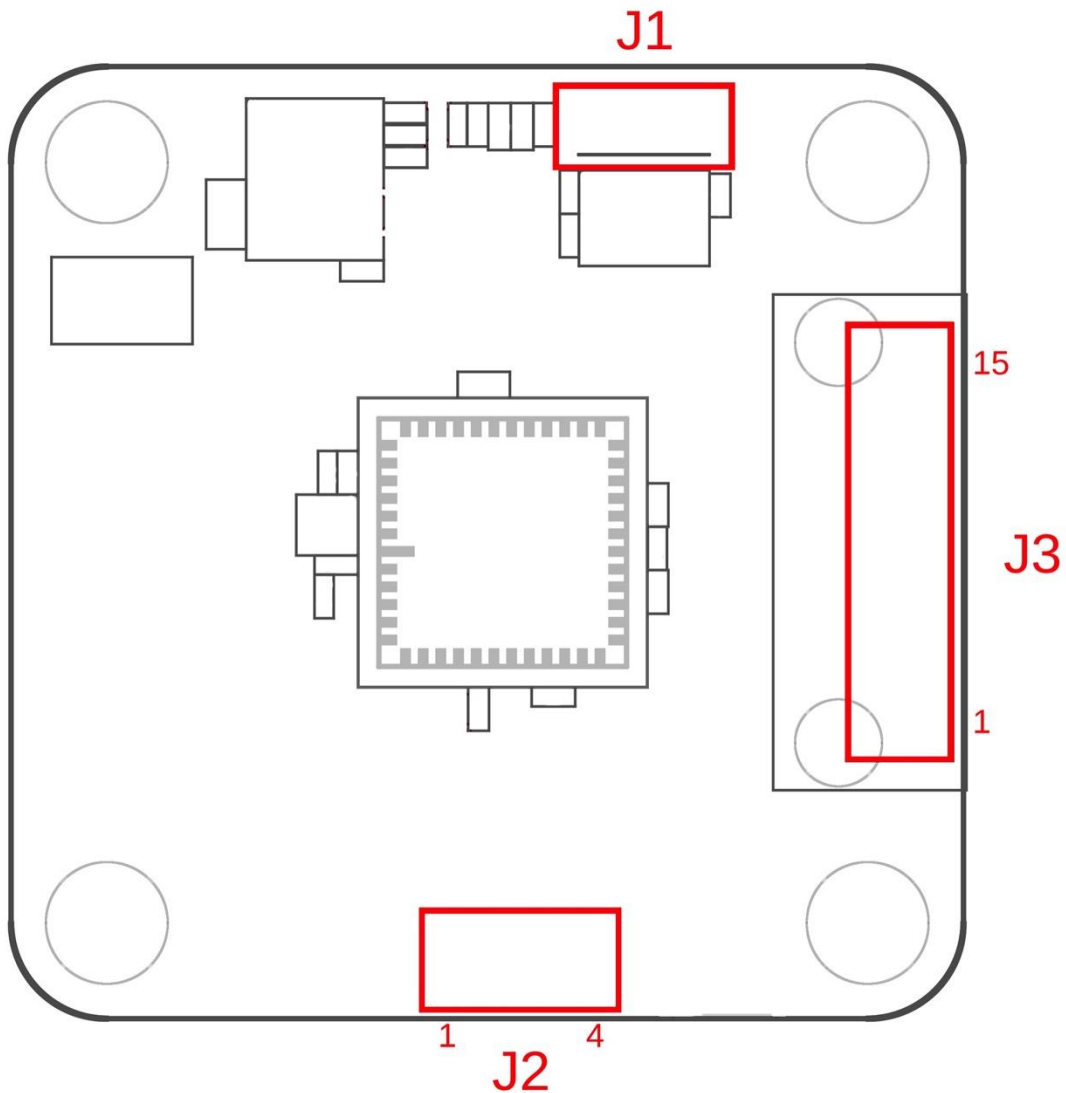

Figure 2 Topside hardware layout with connectors and pin numbers.

3.1 J1: USB Connector

J1 is a standard USB Micro-B connector used for production and update of the system firmware. It is not possible to use USB for general operation of the NanoCam.

3.2 J2: GOSH Connector

Picoblade. Right angle. Molex 53261-0471

J2 provides access to the GomSpace Shell (GOSH), which is used for integration and debugging purposes. The interface uses 3.3 V UART levels.

Pin	Description
1	GND
2	Not Connected
3	DRXD
4	DTXD

3.3 J3: Main Connector

Picoblade. Right angle. Molex 53261-1571

This connector is used for supplying power to the C1U and for interfacing with other subsystems.

Pin	Description
1	GND
2	I ² C SCL (CSP I ² C Clock)
3	I ² C SDA (CSP I ² C Data)
4	VCC (3.3 V)
5	CANL (CSP CAN Low)
6	CANH (CSP CAN High)
7	VCC (3.3 V)
8	UART-TXD0 (CSP via TTL Serial)
9	UART-RXD0 (CSP via TTL serial)
10	GND
11	RX P (CSP RS-422, positive receive)
12	TX N (CSP RS-422, negative transmit)
13	TX P (CSP RS-422, positive transmit)
14	RX N (CSP RS-422, negative receive)
15	GND

4 Data Interface

The NanoCam C1U uses the CubeSat Space Protocol (CSP) to transfer data to and from other CSP nodes on the main system bus. CSP is a routed network protocol that can be used to transmit data packets between individual subsystems on the satellite bus and between the satellite and ground station. For more information about CSP please read the documentation on <http://www.libcsp.org> and on Wikipedia: http://en.wikipedia.org/wiki/Cubesat_Space_Protocol

The camera can be operated via CSP on four interfaces: CAN, I²C, RS422 and TTL level serial port. It is possible to enable multiple interfaces simultaneously and use different interfaces for different subsystems on the satellite bus.

4.1 CAN

The CAN interface to the C1U can be used together with CAN Fragmentation Protocol (CFP), a data-link layer protocol specially developed for CSP. CFP is a simple method to make CSP packets of up to 256 bytes span multiple CAN frames of up to 8 bytes each. The CAN rate is configured to 1 Mb/s.

4.2 I²C

The NanoCam can also be operated over multi-master I²C. The C1U uses the same I²C address as the CSP network address per default. Please note that since the CSP router sends out an I²C message automatically when data is ready for a subsystem residing on the I²C bus, the bus must be operated in I²C multi-master mode. I²C slave mode is thus not supported. The I²C rate is set to 400 kb/s.

4.3 RS-422

The NanoCam also supports CSP over a RS-422 serial port using the KISS framing protocol. The default serial port rate is 500 kb/s. (Note RS-422 and TTL level serial port cannot be used simultaneously)

4.4 Serial Port

The NanoCam also supports CSP over TTL level serial port using the KISS framing protocol. The default serial port rate is 500 kb/s. (Note RS-422 and TTL level serial port cannot be used simultaneously)

5 Absolute Maximum Ratings

Stresses above those listed under Absolute Maximum Ratings may cause permanent damage to the C1U. Exposure to absolute maximum rating conditions for extended periods may affect the reliability.

Symbol	Description	Min.	Typ.	Max.	Unit
T _{amb}	Operating Temperature	0		60	°C
T _{stg}	Storage Temperature	-40		85	°C
V _{io}	Voltage on I ² C/serial ports	2.7	3.3	3.6	V

6 Electrical Characteristics

Symbol	Description	Min.	Typ.	Max.	Unit
VCC	Supply voltage	3.2	3.3	3.6	V
I	Supply current			500	mA

6.1 Power Usage

Parameter	Condition	Min	Typical	Max	Unit
Idle			380		mW
Image acquisition	< 5 s per operation		800		mW
Image processing	< 10 s per operation		800		mW
System boot	< 15 s		1300		mW

7 Physical Characteristics

Mass of system without optics: 77 g

8 mm lens

Description	Value	Unit
Mass	167	g
Size	86.0 x 91.7 x 55.1	mm

35 mm lens

Description	Value	Unit
Mass	169	g
Size	86.0 x 91.7 x 57.9	mm

70 mm lens

Description	Value	Unit
Mass	277	g
Size	86.0 x 91.7 x 97.2	mm

8.2 35 mm - 1U version

