



NanoCom AX2150

Datasheet

Software configurable S-band TMTC radio

Product name: NanoCom AX2150

Document No.: 1028153

Revision: 2.2

Confidentiality Notice

This document is submitted for a specific purpose as agreed in writing and contains information, which is confidential and proprietary. The recipient agrees by accepting this document, that this material will not be used, transferred, reproduced, modified, copied or disclosed in whole or in part, in any manner or to any third party, except own staff to meet the purpose for which it was submitted without prior written consent.

GomSpace © 2025

1 Contents

2	Overview	4
2.1	Highlighted Features	5
2.2	Block Diagram.....	6
2.3	Functional Description.....	6
3	Hardware Layout, Connectors and Pin Out	8
3.1	Top Board View	8
3.1.1	J101 - Picoblade Debug Connector	8
3.1.2	ANT 1 - MCX RF Connectors.....	9
3.2	Bottom Board View	10
3.2.1	J105 - FSI Main Connector	10
4	Data Interface.....	11
4.1	I ² C/TWI	11
4.2	KISS	11
4.3	CAN-BUS / CFP.....	12
5	Manual	12
6	Debug Interface	12
7	Absolute Maximum Ratings.....	13
8	Electrical Characteristics	13
9	Physical Characteristics	13
10	RF Characteristics	14
10.1	Transmitter.....	14
10.2	Receiver.....	15
10.2.1	Automatic Frequency Compensation (AFC) performance	16
10.2.2	Occupied bandwidth	16
10.2.3	Suppression of unwanted RF signal (RX filtering).....	17
11	Environment Testing	19
12	Thermal Interfaces.....	19
13	Mechanical Information.....	20
14	Mounting	20

2 Overview

The NanoCom AX2150 is a half-duplex software configurable radio transceiver specifically designed for Telemetry and Telecommand (TMTC) in the S-band. The combination of Forward Error Correction (FEC), Automatic Frequency Control (AFC) and digital channel filter results in a high sensitivity receiver, without sacrificing flexibility. The radio module supports full in-flight reconfiguration of the carrier and intermediate frequencies, symbol rate, framing and encoding options, and channel-filter bandwidth. Smart CSMA/CA (listen before talk) medium access control combined with a small RX/TX switching duration gives a short satellite ping time, thus effectively removing the need for full-duplex radios.

The integrated design of microcontroller, peripherals, transceiver, and RF front-end results in a compact PCB module that fits up to four times onto a CubeSat PCB (stack board). Software and multiple hardware components are based on the NanoCom AX100, which has extended flight heritage by GomSpace customers worldwide since 2014.

The NanoCom AX-Softmodem application is built to serve as the ground-side equivalent to the NanoCom AX2150. The application implements the same datalink and network layer protocols and is built to work with commercial ground station provider systems. More information on the NanoCom AX-Softmodem is available on the GomSpace website or by request.

2.1 Highlighted Features

- Advanced high-performance narrow-band transceiver for S-band TMTC operation.
- Built to be used in combination with the GomSpace NanoCom AX-Softmodem application.
- Compatible with the KSAT KSATLite ground station network (within a subset of configurations).
 - Support from firmware version 3.0.0 and above
 - Compatible configuration description is delivered with the unit or available on request.
- Frequency range: 2025-2110 MHz (uplink) / 2200-2290 MHz (downlink)
- GMSK modulation, BT = 0.5
- Configurable symbol rate from 9.6 kBd to 96 kBd.
- RF carrier frequency and modulation frequency deviation programmable in 1 Hz steps
- Transmitter with adjustable output power (20 mW to 800 mW) in eight predefined steps.
- Automatic frequency control (AFC)
- Raised-cosine pulse shaping
- Frame encapsulation: 32-bit ASM + Golay encoded variable length field.
- Framing options:
 - Reed-Solomon FEC (223,255)
 - CRC32
 - CCSDS Randomization
 - HMAC (authentication)
- Multiple CSP data interfaces: I²C, UART, CAN
- 32 kB FRAM for persistent configuration storage
- RTC clock
- Temperature monitoring and adjustable over-temperature protection
- Brown-out protection
- Current monitoring
- Received Signal Strength Indication (RSSI)
- RX front-end protection against high-power RF signals up to +21 dBm
- MCX antenna connector
- Compact daughter-board form-factor (compatible with GomSpace NanoDock DMC-3)
- ESD protected UART/GOSH console interface for easy use in lab setup
- Operational temperature: -40 °C to +75 °C
- Verified to 20 kRad(Si) unshielded PCBA level
- Mass: less than 32 gram including aluminum shield and cooling block
- PCB material: Glass/Polyimide IPC-4101/40
- IPC-A-610 Class 3 assembly
- An example link budget template is available on request from GomSpace A/S.

2.2 Block Diagram

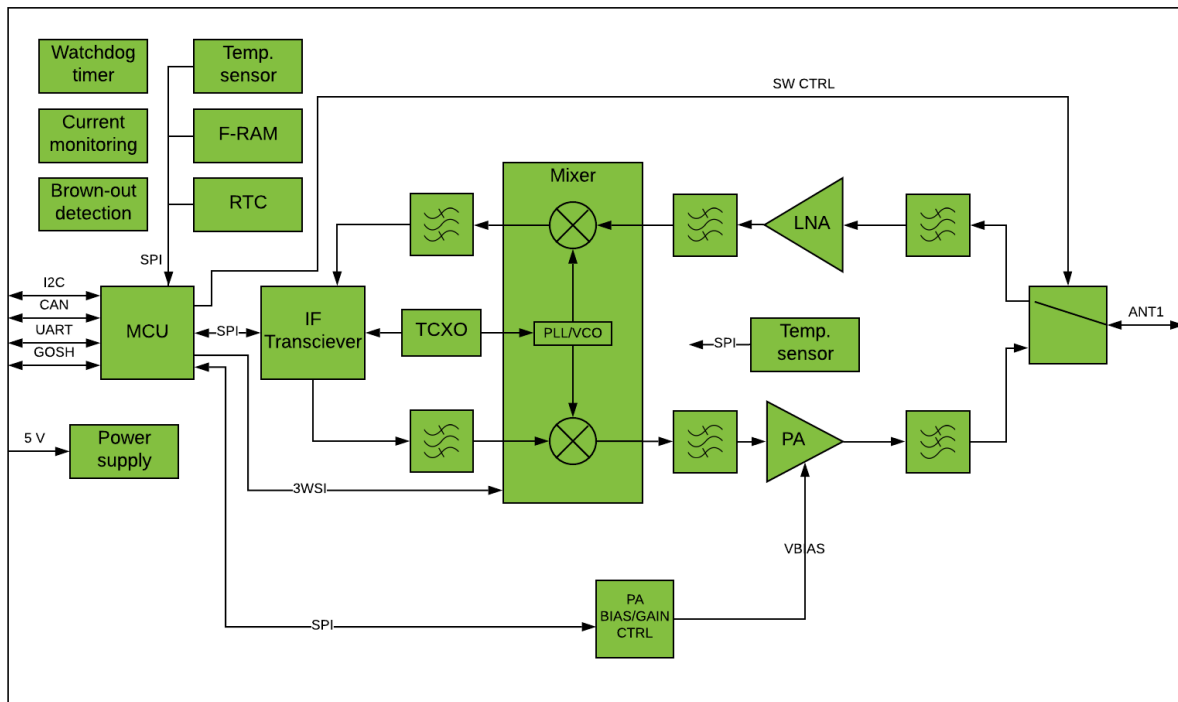

Figure 2-1. NanoCom AX2150 block diagram

The NanoCom AX2150 TMTTC radio consists of a microcontroller, several supporting ICs, an IF transceiver and RF hardware: mixers, filters and amplifiers.

The design is built around space proven components; the MCU, IF transceiver and peripheral interfaces are proven components from previous GomSpace products.

2.3 Functional Description

The microcontroller controls and configures the radio hardware as well as handling routing of data and configuration packets between any of the four interfaces: RF, CAN, I2C and UART.

The microcontroller is supported by several ICs for temperature monitoring, clock and time keeping, system state monitoring and robust, radiation-resistant storage for configuration and telemetry.

The configuration parameters and radio telemetry are collected into a single parameter system which can be accessed from all the interfaces. This allows logging of radio telemetry and reconfiguration of radio parameters, both from ground and other on-board devices.

The radio hardware design is based on the *Superheterodyne radio* concept.

The basic architecture consists of an IF half-duplex transceiver stage –common for RX and TX– followed by an integrated mixer and PLL/VCO section for up/down conversion to the S-band. The RF front-end section is an LNA stage and band filtering. Likewise, the RF front-end in the TX chain comprises band filtering and a PA section with adjustable gain.

The IF transceiver consists of a fully integrated frequency synthesizer with VCO, modulator, demodulator, and base band data processing. The advanced architecture of the synthesizer enables carrier frequency resolutions of 1 Hz, as well as fast settling times of 5 – 50 μ s. Fast settling times mean fast start-up and fast RX/TX switching, enabling low-power system design.

The frequency down/up conversion is carried out by means of a frequency conversion chip with integrated local oscillator generation and a pair of RF mixers. Mixer inputs and outputs are adequately filtered to minimize non-linear intermodulation products such as the image frequency.

The PA section consist of a TX pre-amplifier and a PA with bias power control. Nominal maximum TX output is 0.7 W (28.5 dBm).

A temperature sensor placed on the bottom side of the module monitors the PA temperature. A software programmable maximum temperature can be set, at which point the microcontroller immediately will turn off the transmitter.

An aluminum cooling unit is attached to the NanoCom AX2150 below the TX PA and is connected to the NanoDock DMC-3 board and the satellite ring structure to divert the generated heat of the Nanocom AX2150 to a satellite structure.

The LNA section consist of two stages. The design is based on two RF Low Noise bipolar transistors with a noise figure of 1.5 dB. The LNA input is internal protected against unwanted RF signals up to + 21 dBm. Between the antenna RX/TX switch and the LNA input there is a discrete band pass filter. Between the LNA and the down conversion mixer the design has a SAW filter to filter out image frequencies.

The TCXO has a frequency stability of ± 0.5 ppm over the entire temperature range and removes the need to do frequency-offset calibration after satellite deployment. Initial frequency error is calibrated and compensated as part of the GomSpace production test and calibration. The built-in AFC will correct for any minor frequency variations up to +/- one quarter of the IF transceiver RX bandwidth.

	Frequency range supported
NanoCom AX2150	RX: 2025 – 2110 MHz TX: 2200 – 2290 MHz

3 Hardware Layout, Connectors and Pin Out

3.1 Top Board View



Figure 3-1. Nanocom AX2150 debug connector

3.1.1 J101 - Picoblade Debug Connector

The Picoblade Debug connector GOSH USART interface.

The debug USART is designed for easy access to the NanoCom AX2150 configuration and makes it possible to do factory checkout of standalone modules.

The NanoCom AX2150 module will be shipped with firmware pre-installed. Uploading new firmware will void the factory checkout.

Note: user will have to use this interface to save the default spacecraft configuration into the FRAM write protected area.

Note: it is not recommended to use this interface for flight operations. Use the Main Connector J105 instead.

Serial port settings are 500000 baud and 8n1.

All pins are ESD protected with TVS diode (type WE-824015) ±12 kV contact discharge.

Pin	Name	Description
1	Reserved	JTAG
2	Reserved	JTAG
3	Reserved	JTAG
4	Reserved	JTAG
5	Reserved	JTAG
6	Reserved	JTAG
7	Reserved	JTAG
8	USART_RX (GOSH) ¹⁾	USART RX (Data to NanoCom AX2150)
9	USART_TX (GOSH)	USART TX (Data from NanoCom AX2150)
10	GND	GND
11	Reserved	Reserved
12	Reserved	Reserved
13	GND	GND

¹⁾ Logic level on USART RX input (master TX) must be low or floating when +5V supply is off to avoid back powering as leakage through the ESD protection diodes. The system may end up in an undefined state when +5V is turned on if the TX side of the USART remains active high.

3.1.2 ANT 1 - MCX RF Connectors

The RF connector is 50 Ω MCX. Type Samtec MCX-J-P-H-ST-EM1.

Connector	Name	Description
J102	ANT 1	Antenna connector



Figure 3-2. Examples of MCX connector and cables

Warning: Do not transmit without a proper 50 Ω termination. This will reflect the TX power back into the transmitter and may cause damage to the RX/TX switch and the power amplifier.

3.2 Bottom Board View

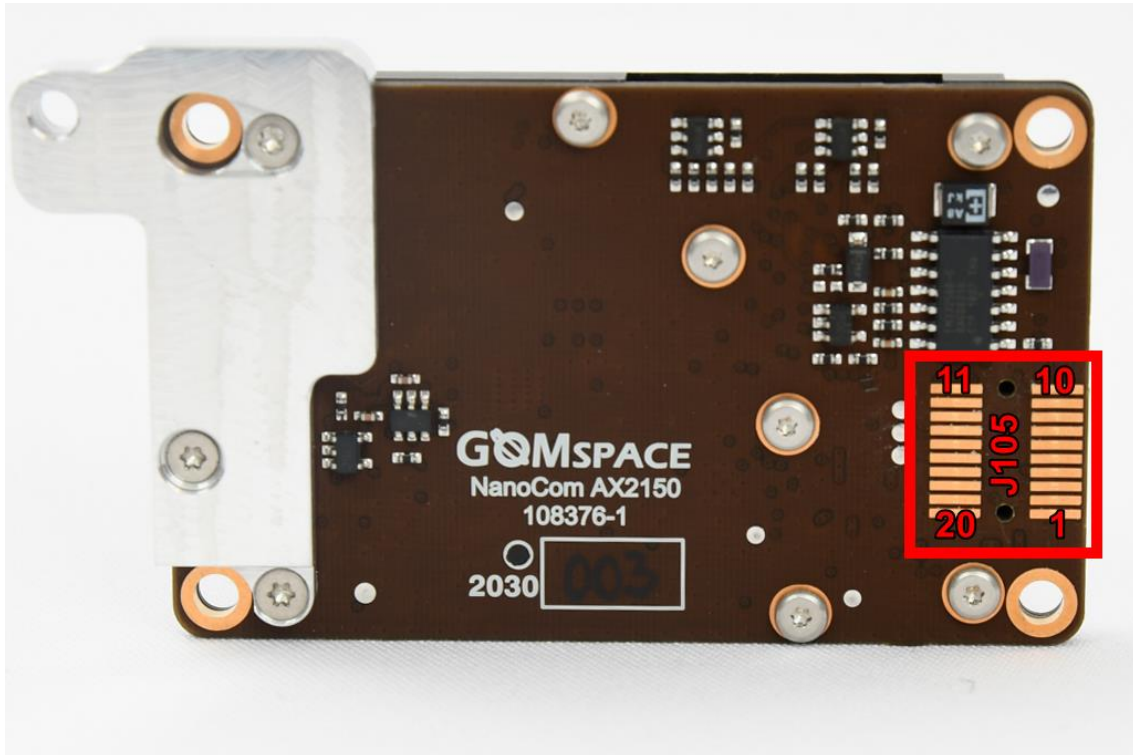

Figure 3-3. Bottom board view

3.2.1 J105 - FSI Main Connector

The main connector is built into the PCB as a 20-position hard-gold plated FSI one-piece connector. The mating part SAMTEC-FSI-110-D is placed at the NanoDock. The module is connected to the NanoDock PCB by fastening it with 4 screws. The alignment is done with two plastic pins that fit in two holes on the NanoCom AX2150 module. The overall stacking height between the NanoDock and the NanoCom AX2150 module's backside is 3.0 mm.

Pin	Description	Pin	Description
1	GND	20	GND
2	GND	19	GND
3	VCC +5.0 V	18	VCC +5.0 V
4	VCC +5.0 V	17	VCC +5.0 V
5	I ² C SCL	16	Not connected
6	I ² C SDA	15	Not connected
7	CAN high line	14	Not connected
8	CAN low line	13	Not connected
9	USART0 RX (data to NanoCom AX2150)	12	Reserved
10	USART0 TX (data from NanoCom AX2150)	11	Reserved

ESD protection on communication pins:

I²C via bus buffer (LTC4303) ±15 kV human body model.

CAN via CAN Transceiver (LTC2875) ±25 kV

USART pins are directly connected to MCU. No extra ESD protection.

Logic level on USART RX input (master TX) must be low or floating when +5V supply is off to avoid back powering as leakage through the ESD protection diodes inside the MCU. The system may end up in an undefined state when +5V is turned on if the TX side of the USART remains active high.

GND pins and chassis are interconnected. All gold plated through holes on the AX2150 PCB are connected to GND. Meaning the cooling unit, anodized aluminum shield and corner mounting holes and MCX outer contact ring are all electrically equivalent to GND.

4 Data Interface

The NanoCom AX2150 uses the CubeSat Space Protocol (CSP) to transfer data to and from CSP nodes on-board the main system bus. CSP is a routed network protocol that can be used to transmit data packets between individual subsystems on the satellite bus and between the satellite and ground station. For more information about CSP please read the documentation on libcsp.org and on Wikipedia: http://en.wikipedia.org/wiki/Cubesat_Space_Protocol

The CSP network layer protocol spans multiple data-link layer protocols, such as KISS, I²C and Can Fragmentation Protocol (CFP).



4.1 I²C/TWI

The standard method to communicate with the NanoCom AX2150 radio is over multi-master I²C/TWI. Please note that since the CSP router sends out an I²C message automatically when data is ready for a subsystem residing on the I²C bus. The bus needs to be operated in I²C multi-master mode. Currently there is no support for I²C slave mode.

The NanoCom AX2150 uses the same I²C address as the CSP network address per default. This means that if a message is sent from the radio link to a network node called 1, the NanoCom AX2150 will route this message to the I²C interface with the I²C destination address 1.

The NanoCom AX2150's own I²C address is 0x05 per default.

4.2 KISS

The KISS protocol uses special framing characters to identify a data-packet on a serial connection. It is designed to be easy to implement in simple embedded devices, which are capable of asynchronous serial communications. [http://en.wikipedia.org/wiki/KISS_\(TNC\)](http://en.wikipedia.org/wiki/KISS_(TNC))

It is possible to communicate with the NanoCom AX2150 over a serial connection using USART0 in the main FSI connector or on the debug output. *Note: Please be aware that the debug USART is also used for debugging messages so it is not recommended for the main data interface for the NanoCom AX2150. Because debug messages and KISS data frames can collide and thereby corrupt a message.*

4.3 CAN-BUS / CFP

The CAN interface can be used together with CAN Fragmentation Protocol (CFP), a data-link layer protocol specially developed for CSP. CFP is a simple method to make CSP packets of up to 256 bytes, span multiple CAN messages of up to 8 bytes each. The easiest way to implement CSP/CFP over CAN is to download the CSP source code from <http://libcsp.org> and compile the CFP code directly into your own embedded system.

5 Manual

To obtain more information about how to control and program the NanoCom AX2150 it is recommended to find information in the NanoCom AX2150 manual (gs-man-nanocom-ax2150) Available on request from GomSpace A/S.

6 Debug Interface

The debug interface is a USART that uses the GomSpace Shell (GOSH) to present a console-like interface to the user. GOSH is a general feature present on all GomSpace products. To read more about GOSH please check <https://gomspace.com/home.aspx>

The console is used during checkout of the NanoCom AX2150 to send commands and parameter settings. During integration into the satellite, the debug interface can be used to evaluate and see incoming and outgoing traffic through the NanoCom AX2150 radio. Telemetry and housekeeping parameters can also be monitored. Here is a short list of features of the debug interface:

- Inspect CSP traffic (incoming and outgoing)
- Inspect runtime performance
- Run tests (ping, BER, etc.)
- Modify routing table
- Modify, save, and restore default parameters
- Set Frequency, Symbol rate, Bandwidth, Transmit power etc.

7 Absolute Maximum Ratings

Stresses above those listed under Absolute Maximum Ratings may cause permanent damage to the NanoCom AX2150. Exposure to absolute maximum rating conditions for extended periods may affect reliability.

Symbol	Description	Min.	Max.	Unit
V _{CC}	Supply voltage	-	+5.5	V
I	Supply current draw	-	1.0	A
P _{in}	Absolute maximum input power at receiver input ¹⁾		+21	dBm
T _{operation}	Operating Temperature	-40	+75	°C
T _{storage}	Storage Temperature	-40	+85	°C
V _{io}	Voltage on I ² C / USART	-0.3	+3.6	V
V _{SVR}	Output Load VSWR		10:1	

8 Electrical Characteristics

Symbol	Description	Min.	Typ.	Max.	Unit
V _{CC}	Supply voltage	4.8	5.0	5.3	V
I _{RX}	RX current consumption		108	115	mA
I _{TX}	TX current consumption ²⁾		650	850	mA

Typical AX2150 TX output power and current consumption.

TX Power level	Min P _{out}	Max P _{out}	Unit	Min I _{TX}	Max I _{TX}	Unit
tx_pwr = 0	27.5	30.0	dBm	550	850	mA
tx_pwr = 1	27.0	29.5	dBm	500	720	mA
tx_pwr = 2	25.7	28.5	dBm	450	680	mA
tx_pwr = 3	23.0	27.0	dBm	400	575	mA
tx_pwr = 4	21.0	25.0	dBm	300	500	mA
tx_pwr = 5	17.5	22.5	dBm	220	450	mA
tx_pwr = 6	14.5	19.0	dBm	200	350	mA
tx_pwr = 7	10.5	15.5	dBm	175	300	mA

P_{out} is with reference to ANT 1 connector J102 when terminated with 50ohm load impedance.

9 Physical Characteristics

Description	Value	Unit
Mass	32	g
Size (including cooling unit) ³⁾	43 x 75 x 9.0	mm

¹⁾ To prevent the RX LNA it is vital that precautions is taken to evaluate the coupling from other transmission system on a spacecraft to the NanoCom AX2150 RF connector. Maximum unwanted RF level is to be below the specified value.

²⁾ Current is dependent on TX output power setting and ANT 1 load impedance. The listed figure is applicable for tx_pwr = 0 and 50ohm load impedance.

³⁾ For detailed mechanical measures, please see the 2d cad drawing for the Nanocom AX2150 or the 3D model. Both will be available on request to GomSpace A/S

10 RF Characteristics

10.1 Transmitter

Symbol	Description	Min.	Typ.	Max.	Unit
f_{TX}	TX frequency range	2200		2290	MHz
$f_{TX, IF}$	TX Intermediate frequency	462	465 ¹⁾	468	MHz
$f_{TX, LO}$	TX Local Oscillator	1735 ²⁾		1825 ²⁾	MHz
P_{out}	Output power at RF connector @ max power setting.	+27.5	+28.5	+30	dBm
P_{out}	Adjustable TX power range ³⁾	13		28.5	dBm
H_2	2 nd harmonic @ max tx power		-30	-25	dBm
H_3	3 rd harmonic @ max tx power		-40	-25	dBm
H_5	5 th harmonic @ max tx power		-35	-25	dBm
SBR_{TX}	Symbol rate	9.6		96.0 ⁴⁾	kBd
$F_{stability}$	Frequency stability [-40, +85 °C]		± 0.3 ⁵⁾	± 0.5	PPM
P_{no}	Phase noise, 1 MHz offset	-100	-105		dBc/Hz
F_{step}	Programmable Frequency Step		1		Hz
T_{start}	Synthesizer start up time	5	20	25	ms
P_{adj}	Adjacent channel power, 9.6 kbps, 50kHz channel spacing		-38	-33	dBc

- 1) It is recommended to use the typical value when possible. In case other value of the Intermediate Frequency is needed, it is recommended to stay well within the boundary of the TX Intermediate frequency to secure no issues with IF SAW pass band as function of temperature changes.
- 2) With $f_{TX, IF} = 465$ MHz.
- 3) TX output power is adjustable in 8 predefined power levels at the RF connector.

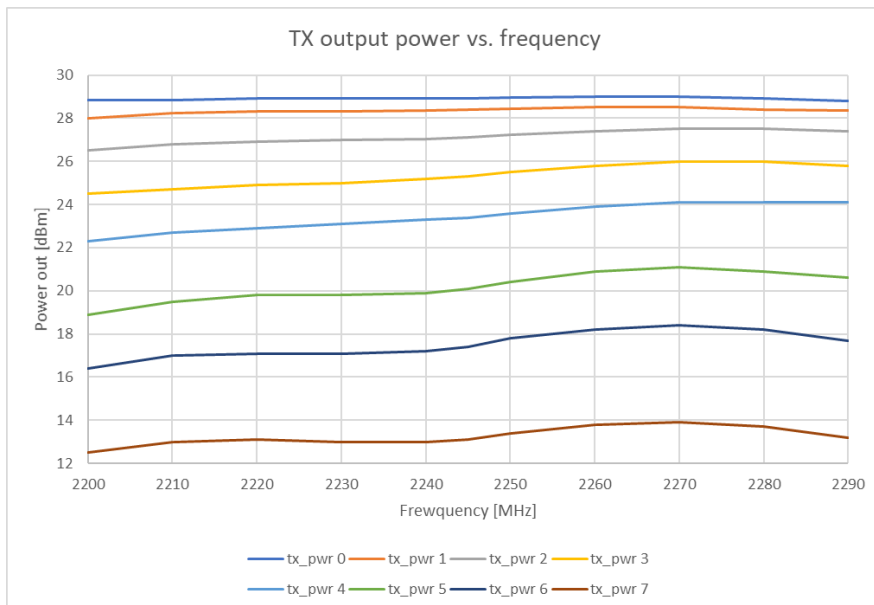

Figure 10-1. Typical TX output power vs. frequency @ RF connector

- 4) TX power setting must be adjusted accordingly to SBR to full fill the ITU Regulations for maximum power flux density on the earth surface.
- 5) The frequency stability specification is specified for the temperature impact. Aging is not included. Initial frequency tolerance is calibrated and compensated during GomSpace factory testing and calibration.

10.2 Receiver

Symbol	Description	Min.	Typ.	Max.	Unit
f_{RX}	RX frequency range	2025		2110	MHz
$f_{RX, IF}$	RX Intermediate frequency	452	455 ¹⁾	458	MHz
$f_{RX, LO}$	RX Local Oscillator	1570 ²⁾		1655 ²⁾	MHz
RX system NF	RX Noise Figure at RF connector	1.8	2.1	2.5	dB
Sens_{9600,NO-FEC}	Sensitivity 9600 baud wo/ FEC. BER = 10^{-6}		-113		dBm
Sens_{19200,NO-FEC}	Sensitivity 19200 baud wo/ FEC BER = 10^{-6}		-111		dBm
Sens_{38400,NO-FEC}	Sensitivity 38400 baud wo/ FEC BER = 10^{-6}		-108		dBm
SBR_{RX}	Symbol rate	9.6		96.0	kBd
R_{AFC}	AFC pull-in range		25		% IF BW
R_{DROFF}	Data rate pull-in range		10		%

- 1) It is recommended to use the typical value when possible. In case other value of the Intermediate Frequency is needed, it is recommended to stay well within the boundary of the RX Intermediate frequency to secure no issues with IF SAW pass band as function of temperature changes.
- 2) with $f_{RX, IF}=455$ MHz.

The figure below shows the typical sensitivity as a function of received signal strength at different bitrates. It is shown as raw bitrate without any bit correction coding for a repeating bitstream of binary 01010101.

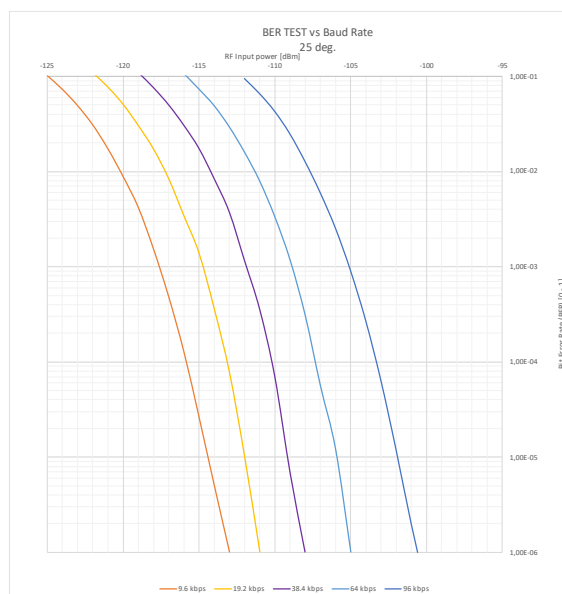

Figure 10-2.Receiver sensitivity. Typical BER vs. RF input power

10.2.1 Automatic Frequency Compensation (AFC) performance

The receiver has an AFC tracking function. The following graph shows that there is no AFC performance penalty until the boundary for the AFC tracking is met at $\pm 25\%$ of the IF Receiver filter bandwidth.

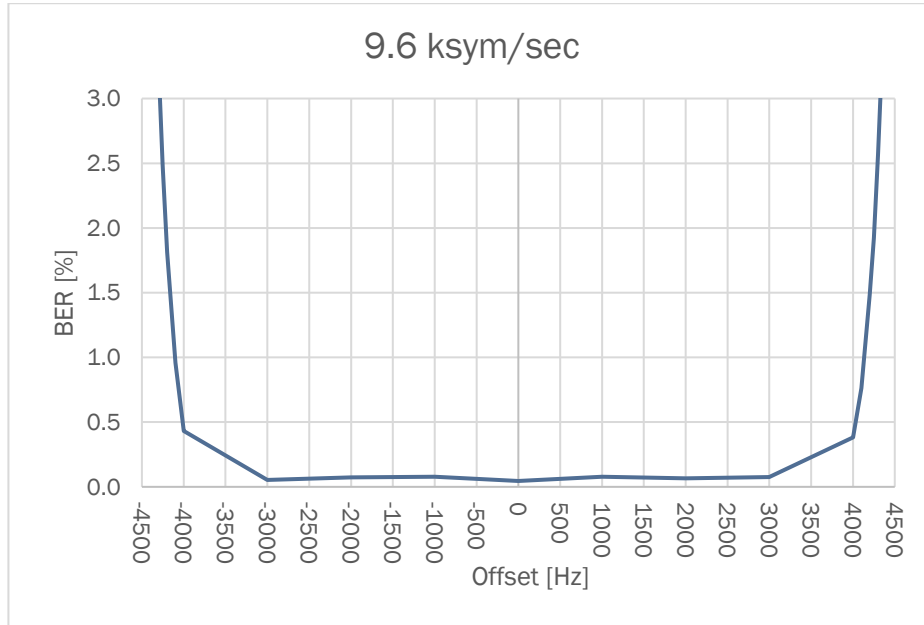

Figure 10-3. AFC performance at 9k6 baud

10.2.2 Occupied bandwidth

The measured 99% occupied bandwidth is shown in Figure 10-4.

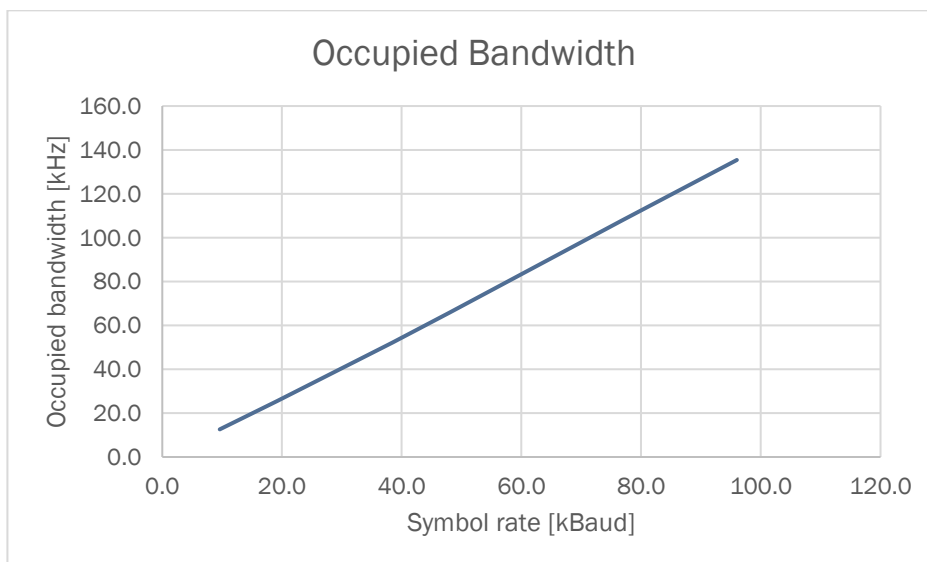

Figure 10-4 Occupied bandwidth as a function of symbol rate

10.2.3 Suppression of unwanted RF signal (RX filtering).

The NanoCom AX2150 achieves high channel selectivity in the receiver using built-in filtering.

Figure 10-4 shows the setup used to test the suppression levels and Figure 10-6 shows the maximum level for an unwanted blocking RF signal.

Wanted signal level is 3 dB above sensitivity level for 1% BER.

Unwanted signal is injected and increased until 1% BER is measured.

The result is shown for an unwanted CW signal and for a QPSK signal with 1 Msymb/sec.

The wanted signal is fixed in level and frequency. The unwanted signal is changed in level for each test frequency until 1% BER level is measured.

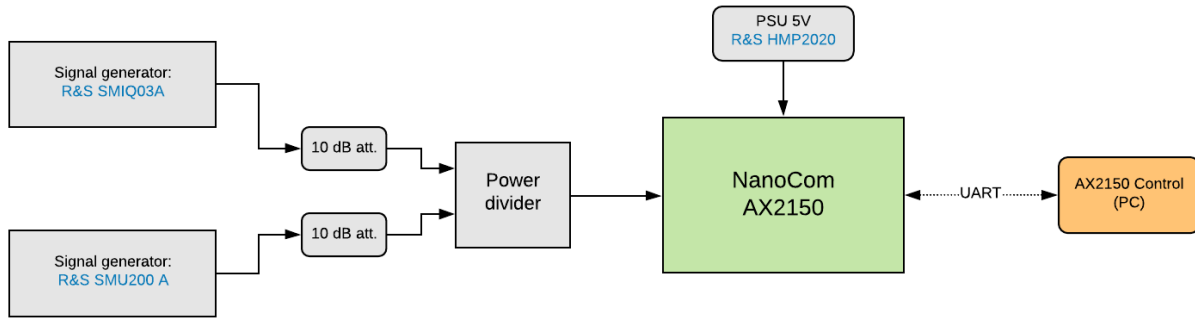

Figure 10-5. Blocking verification setup

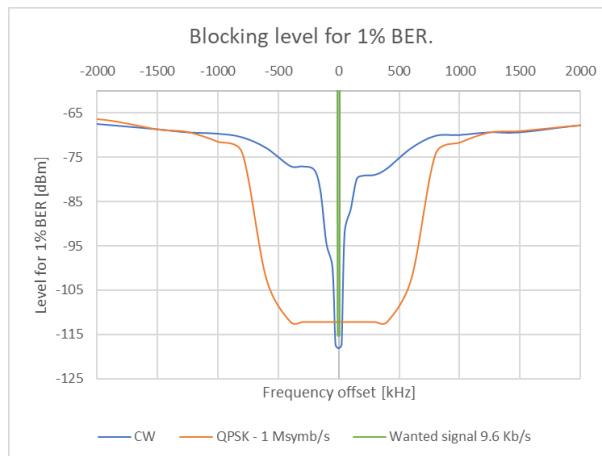

Figure 10-6. Wanted signal 3 dB above 1% BER level.
 Typical max level for unwanted signal ± 2 MHz from wanted carrier

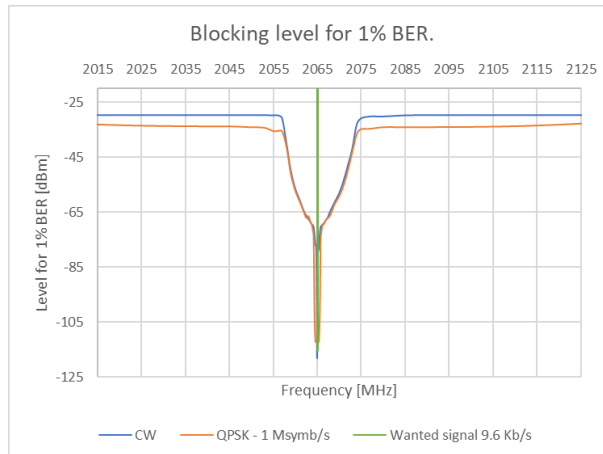

Figure 10-7. Wanted signal 3 dB above 1% BER level.

Typical max level for unwanted signal inside S-Band.

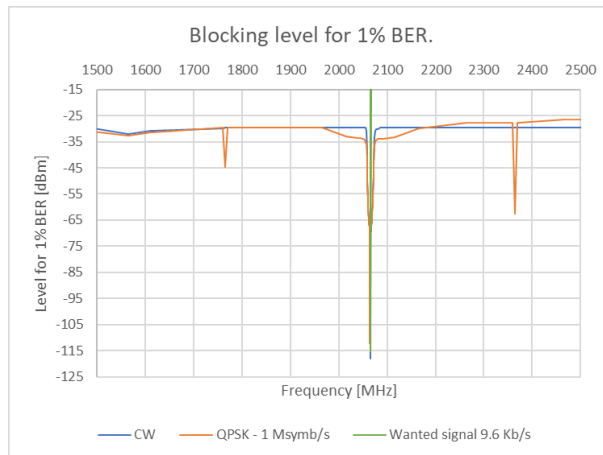

Figure 10-8. Wanted signal 3 dB above 1% BER level.

Typical max level for unwanted signal from 1.5 GHz to 2.5 GHz

11 Environment Testing

To qualify that the NanoCom AX2150 is able survive the harsh conditions of launch and space, the NanoCom AX2150 has been exposed to a number of environment tests according to the GomSpace standard product qualification test procedure. For detailed information about the tests please contact GomSpace A/S.

12 Thermal Interfaces

The thermal interface of the unit is defined on the face marked with red in Figure 12-1, being the “mounting ring bracket” interface typically used for mounting the unit in a standard structure. Note that this bracket (part no. 104603) is not a part of the standard AX2150 product but can be ordered separately from GomSpace in case your selected satellite structure does not come with such ring brackets already.

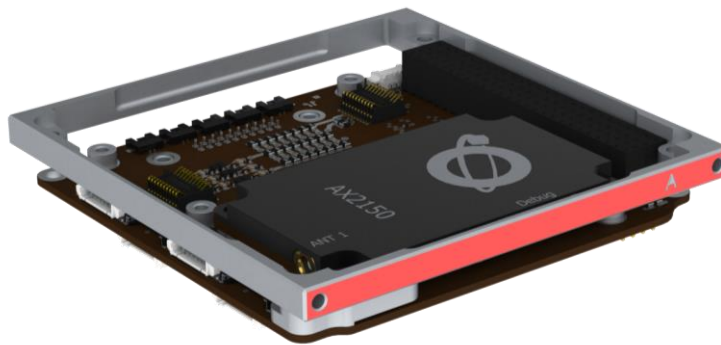

Figure 12-1: Thermal Interface

To predict the critical component temperature (the PA) the following first order lumped parameter model (LPM) can be utilized:

$$T_{PA}(t) = R \left(1 - e^{-\frac{t}{R \cdot C}} \right) P_{DC}(t) + T_{IF}(t)$$

, where T_{PA} is the predicted temperature for the critical component (PA), T_{IF} is the thermal interface temperature as a function of time, P_{DC} is the DC power consumption of the module as a function of time, R is the thermal resistance at T_{IF} , C is the heat capacity of the AX2150 module and t is the time. Model parameters based on TVAC measurement data can be found in Table 12-1.

Table 12-1: Thermal LPM parameters

Parameter	Description	Typical Value	Recommend operating range
R	Thermal Resistance	4.53K/W	
C	Heat Capacity	8.15 J/K	
T_{IF}	Interface temperature	55°C	-40°C to 65°C
t	Time in seconds		0 to 15minutes
P_{DC}	DC power consumption during TX/RX	2W	0.5W to 2.2W
T_{PA}	Predicted PA temperature	64°C	-40°C to 75°C

13 Mechanical Information

2D and 3D CAD models of AX2150 are available for download at www.gomspace.com.

To retrieve models:

- Go to the [GomSpace Customer Portal](#)
- Create a user login.
- Browse to Products > Communication Systems > NanoCom AX2150.
- AX2150 CAD models can be downloaded via CAD link under Technical Documents.

14 Mounting

The NanoCom AX2150 module should be placed on a NanoDock that can provide the physical interface to the PC-104 sub-system stack.

A piece of THERM-A-GAP filler is included with AX2150 to minimize the thermal resistance between AX2150 and NanoDock. Figure 14-1 illustrates where the filler is to be fitted.

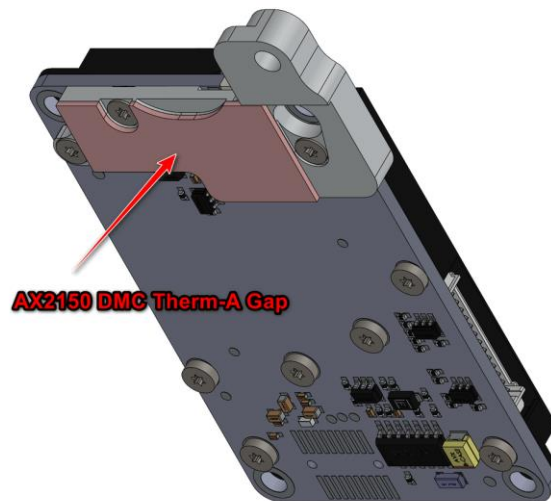

Figure 14-1: AX2150 DMC Therm-A Gap filler placement.