

NanoPower P110

Datasheet

High efficient solar panel for nano-satellite with integrated coarse sun sensor, magnetorquer and thermistor.

Product name: NanoPower P110

Document No.: 1014192

Revision: 2.10

Author: KLK

Approved by: MB

Approval date: 22 October 2018

Confidentiality Notice

This document is submitted for a specific purpose as agreed in writing and contains information, which is confidential and proprietary. The recipient agrees by accepting this document, that this material will not be used, transferred, reproduced, modified, copied or disclosed in whole or in part, in any manner or to any third party, except own staff to meet the purpose for which it was submitted without prior written consent.

GomSpace © 2018

1 Table of Contents

2	OVERVIEW	4
2.1	Highlighted Features.....	5
2.2	Warnings.....	5
2.3	Configurations.....	6
3	HARDWARE LAYOUT	8
3.1	Connector Location.....	8
3.2	H1 - Solar Cell Output.....	8
3.3	H2 - Solar Cell Chain (only on 'S' models)	8
3.4	H3 - ADCS	9
4	ELECTRICAL CHARACTERISTICS	9
5	PROTOCOLS.....	9
6	P110UC-SUN	10
7	CUSTOM PANELS	11
7.1	Case.....	11
8	MECHANICAL DRAWING.....	12
8.1	P110A	12
8.2	P110B	13
8.3	P110C.....	14
8.4	P110UC-SUN	15
9	DISCLAIMER	16

2 Overview

The NanoPower P110 (P110) solar panels are designed and built to the highest standards for a maximum reliability power plant for any nano-satellite. Reliability and performance are combined into a highly efficient panel that offers both energy production and means of attitude determination and control.

P110 Series solar panels is an integrated side panel solution for nano-satellites which provides both solar cells, magnetorquer, sun sensor and temperature sensor all on a single PCB 1.6 mm thick.

The photovoltaic string consists of two series-connected AzurSpace 3G30A space qualified triple junction solar cell assemblies with CMX 100 cover glass. The cells are interconnected by three welded, silver plated kovar interconnectors, and the same type of interconnectors are used to connect the anode and cathode to 70 μm copper tracks on the panel front. The interconnectors are welded to the top of the cells by the manufacturer of the cells (AzurSpace) using a classified process, and the welds are covered by adhesive and cover glass.

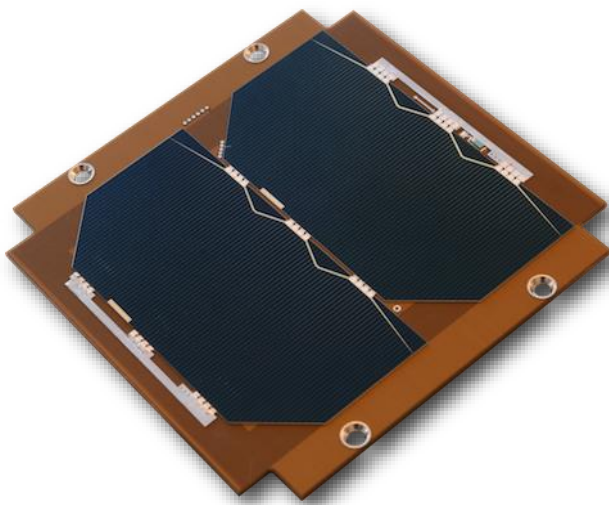

Figure 1 P110C top

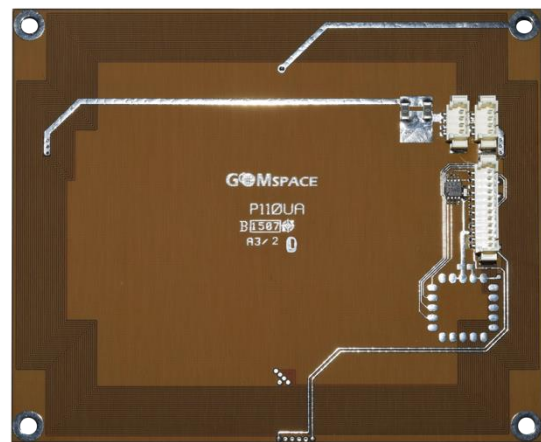

Figure 2 P110UAS bottom

The rear-side welds are performed by GomSpace using an ultra-sonic heavy-bonder applying 12 welds per interconnector.

The anode of the PV string is routed on the rear side of the panel and connected to a Schottky blocking diode which allows parallel-connection of multiple P110 panels. It is also possible to omit the blocking diode and mount an extra connector to enable series connection of P110 panels.

On "U"-models a magnetorquer is integrated into the PCB in 10 internal layers thus taking up no extra space inside the spacecraft, and with an effective area of 1.55 m².

To assist in attitude determination, the panel also features a photo diode to be used as a coarse sun sensor. A temperature sensor is mounted close to the diode to enable compensation for its temperature drift.

2.1 Highlighted Features

- 30% efficiency
- Up to 2.3 W in LEO
- Two series-connected AzurSpace 3G30A space qualified triple junction solar cell assemblies
- CMX 100 cover glass – 100 μm
- 60.36 cm^2 effective cell area
- Cell base material: GaInP/GaAs/Ge on Ge substrate
- Panel base material: Space qualified glass/polyimide laminate with 2 internal 70 μm copper ground planes (10 planes in panels with magnetorquer)
- Cell bonding substrate: 1mil polyimide film with silicone pressure sensitive adhesive
- Plated, countersunk mounting holes with ground connection
- Silver-plated kovar interconnectors - 3 parallel interconnectors per string
- Integrated magnetorquer of 1.55 m^2
- Coarse sun sensor
- Temperature sensor
- Operational temperature: -40 $^{\circ}\text{C}$ to +85 $^{\circ}\text{C}$
- Available in 10 variants

2.2 Warnings



Handling

This product uses advanced solar cells that are fragile. Do not touch solar cells.

Only handle solar panels by touching PCB edges!

Never place anything on solar cells!



ESD

This product uses semiconductors that can be damaged by electrostatic discharge (ESD). When handling, care must be taken so that the devices are not damaged. Use appropriate precautions.



Use

This is a highly advanced product. Make sure to read and understand product documentation before taking it into use.

2.3 Configurations

The NanoPower P110 comes in 10 standard configurations. The A, B and C models have different profile and screw hole positions. The "U"-models, have ADCS capabilities (integrated magnetorquer and coarse sun sensor). The S version is used as an intermediate solar panel in a 2U or larger nano-satellite for serial connecting panels.

P110A	P110UA
P110B	P110UB
P110C	P110UC
P110AS	P110UAS
P110BS	P110UBS

Legend	
A/B/C	Model
U	Internal Coil (magnetorquer)
S	Serial connectable (two 4 pin picoblade)

If larger solar panels are needed, either use a custom solar panel (see chapter 7) or use GomSpace Interstages (see datasheet).

Below is an example of a 3U setup.

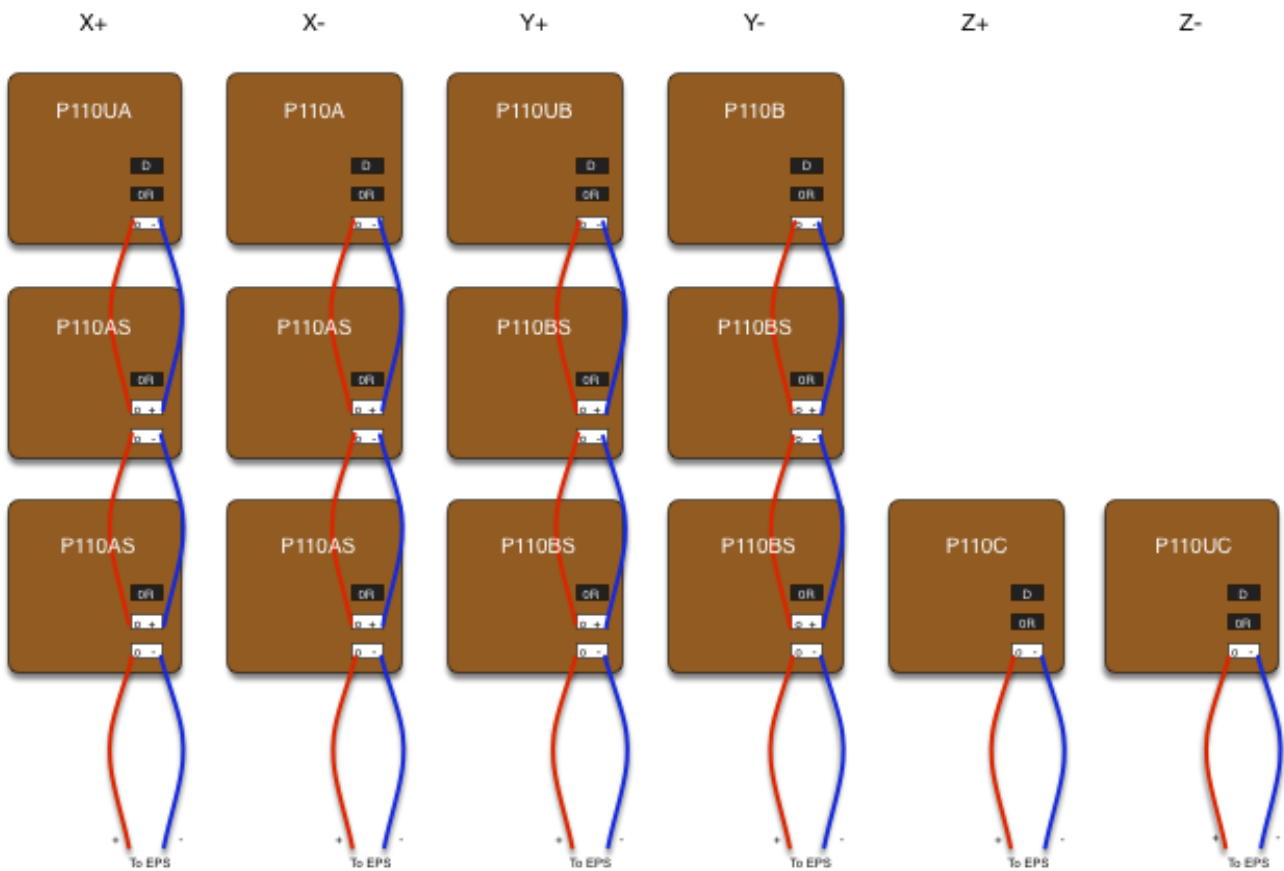

Figure 3 Example of 3U solar panel setup

Below is shown the different profiles and the difference in mass and thickness. Notice the shape and hole positions.

Panel Models		
<p>P110A 2 pcs. 3G30A SCA Blocking diode Coarse Sun sensor Temperature sensor Mass: 26 g PCB thickness: 1.1 mm</p>	<p>P110UA 2 pcs. 3G30A SCA Blocking diode Magnetorquer Coarse Sun sensor Temperature sensor Mass: 57 g PCB thickness: 1.6 mm</p>	
<p>P110B 2 pcs. 3G30A SCA Blocking diode Coarse Sun sensor Temperature sensor Mass: 26 g PCB thickness: 1.1 mm</p>	<p>P110UB 2 pcs. 3G30A SCA Blocking diode Magnetorquer Coarse Sun sensor Temperature sensor Mass: 57 g PCB thickness: 1.6 mm</p>	
<p>P110C 2 pcs. 3G30A SCA Blocking diode Coarse Sun sensor Temperature sensor Mass: 29 g PCB thickness: 1.1 mm</p>	<p>P110UC 2 pcs. 3G30A SCA Blocking diode Magnetorquer Coarse Sun sensor Temperature sensor Mass: 65 g PCB thickness: 1.6 mm</p>	

3 Hardware Layout

The layout of connectors is the same independently of model.

3.1 Connector Location

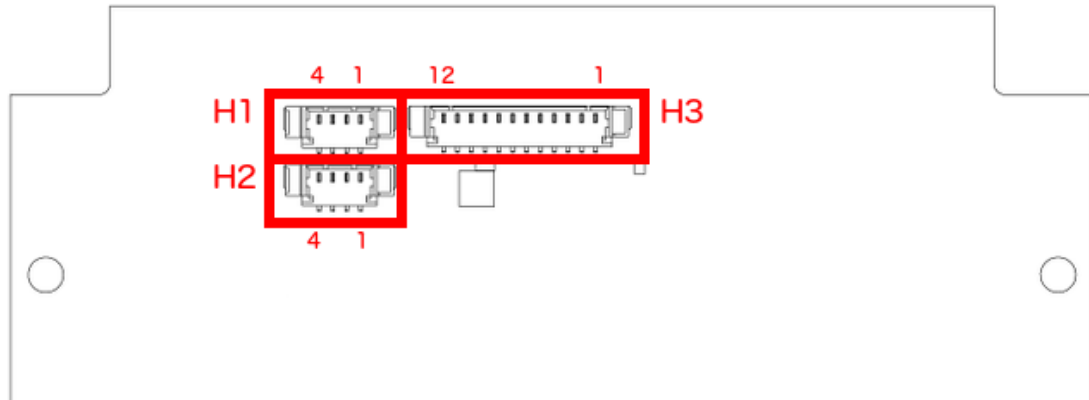

Figure 4 Connectors and pins

3.2 H1 - Solar Cell Output

Molex PicoBlade 53398-0471

Pin	Description
1	Positive
2	Positive
3	Negative
4	Negative

3.3 H2 - Solar Cell Chain (only on 'S' models)

Molex PicoBlade 53398-0471

Pin	Description
1	Negative
2	Negative
3	Positive
4	Positive

3.4 H3 - ADCS

Molex PicoBlade 53398-1271

Pin	Description
1	Magnetorquer +
2	Magnetorquer -
3	Digital ground
4	Not connected
5	Not connected
6	Not connected
7	Sun sensor anode
8	Sun sensor cathode
9	SPI SCLK
10	SPI MISO
11	3.3 V dc digital supply
12	Chip Select temp. sensor (active low)

4 Electrical Characteristics

Parameter	Condition	Min	Typ	Max	Unit
Solar Cell string	Full sunlight in LEO				
• Voltage	Optimal voltage	4.64		4.84	V
• Current	Current at optimal voltage	490		508	mA
• Power	Maximum power	2270		2400	mW
• Efficiency		29.8	30	30.2	%
Course Sun Sensor					
Current	Short current at 1367 W/m ²		930		µA
Cosine error			1.85	3.5	°
Temperature Sensor					
• Range		-55		+150	°C
• Resolution		1.5		3.5	°C
• Vcc			3.3		V
• Current			260	490	µA
• Temperature coefficient		0.21	0.233	0.25	%/°C
Magnetorquer					
• Area			1.55		m ²
• Resistance		120	135	150	Ω
• Current	Absolute maximum rating			1	A
• Dipole momentum	Dipole momentum at 3.3 V	0.034	0.038	0.043	A m ²

5 Protocols

For information regarding the communication protocols for the temperature sensor please refer to the datasheets provided by the manufacturers of these parts.

The temperature sensor is a National Semiconductor LM70

6 P110UC-SUN

A unique P110 has been made for the top or bottom, where the solar panels have been moved to the edge to make room for a GomSpace Fine Sun Sensor in the middle. It still retains its coarse sun sensor, temperature sensor and its magnetorquer.

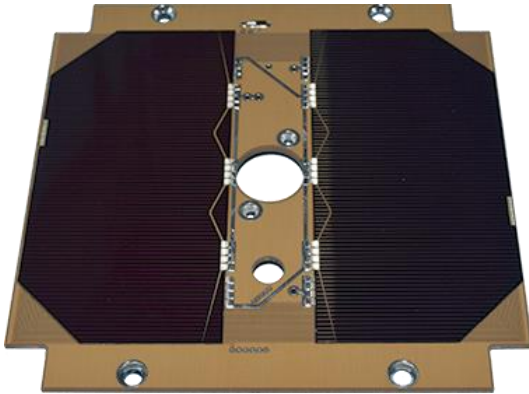

P110UC-SUN seen from the top

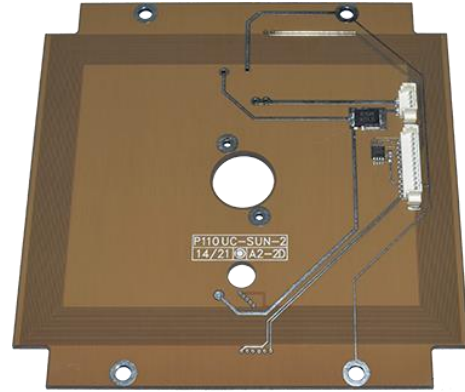

P110UC-SUN seen from the bottom

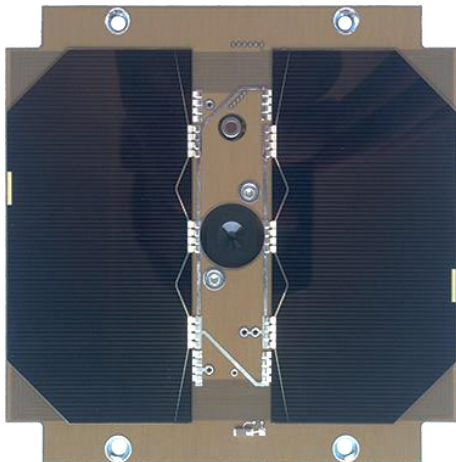

P110UC-SUN with a FSS and a Interstage GSSB C. Seen from the top

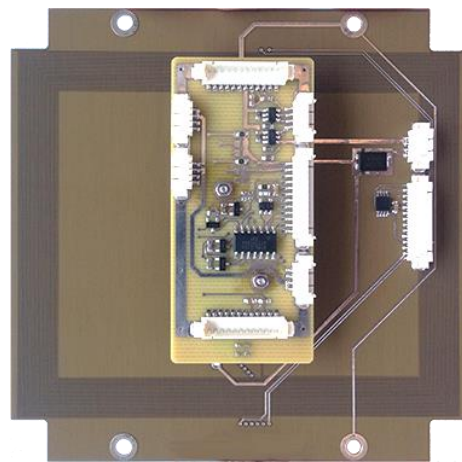

P110UC-SUN with a FSS and a Interstage GSSB C. Seen from the bottom

The GomSpace NanoSense FSS and NanoUtil Interstage GSSB are ordered separately.

7 Custom Panels

In many cases it may be desirable to use a custom structure rather than a standard configuration for a specialized CubeSat, and in these cases, a custom solar panel solution may be required. The design and production process surrounding the NanoPower P110 solar panels allows tailoring of both the form factor and string layout of the panel to meet specific customer requirements. As long as some basic guidelines are met, a custom panel can be designed, produced and qualified in as little as 10 weeks. The cost of a custom panel is very dependent on the requirements, but a price quote can be obtained within a few days of inquiring.

The main guidelines for fast turn-around custom panels are:

1. The cells must be AzurSpace 3G30A SCA. If bypass diodes are required then cost and lead time will increase. Bypass diodes are recommended for strings of more than 3 cells.
2. The panel base material should be same as P110, i.e. glass/polyimide PCB appr. 1 mm thick for panels without magnetorquer and 1.6-1.8 mm thick for panels with magnetorquer.
3. Connectors and sensors should be the same as P110, otherwise extra cost and lead time may be required.

7.1 Case

The photo below shows an example of a completely custom solar panel for a 2-Unit CubeSat. This panel employs two photovoltaic strings with bypass diodes and redundant blocking diodes on both strings. The materials and components are the same as a standard P110 panel.

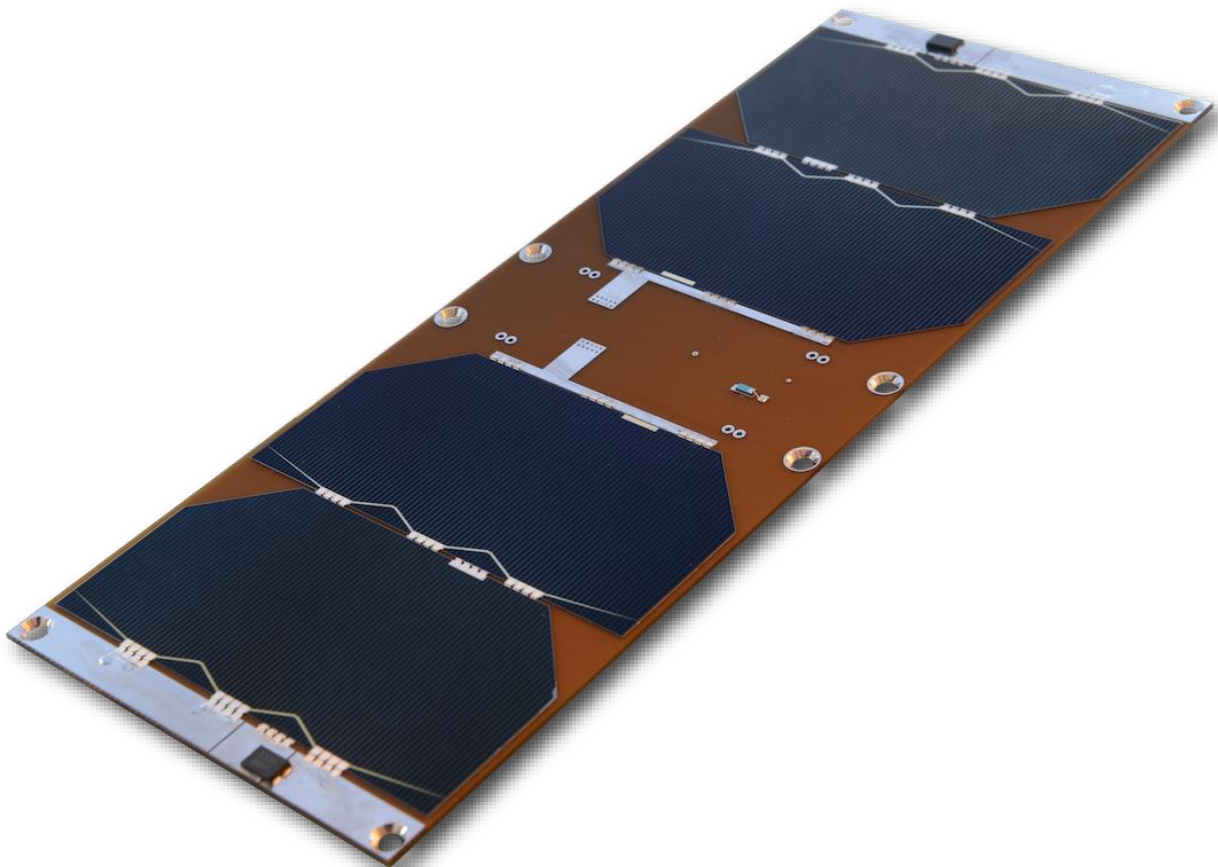
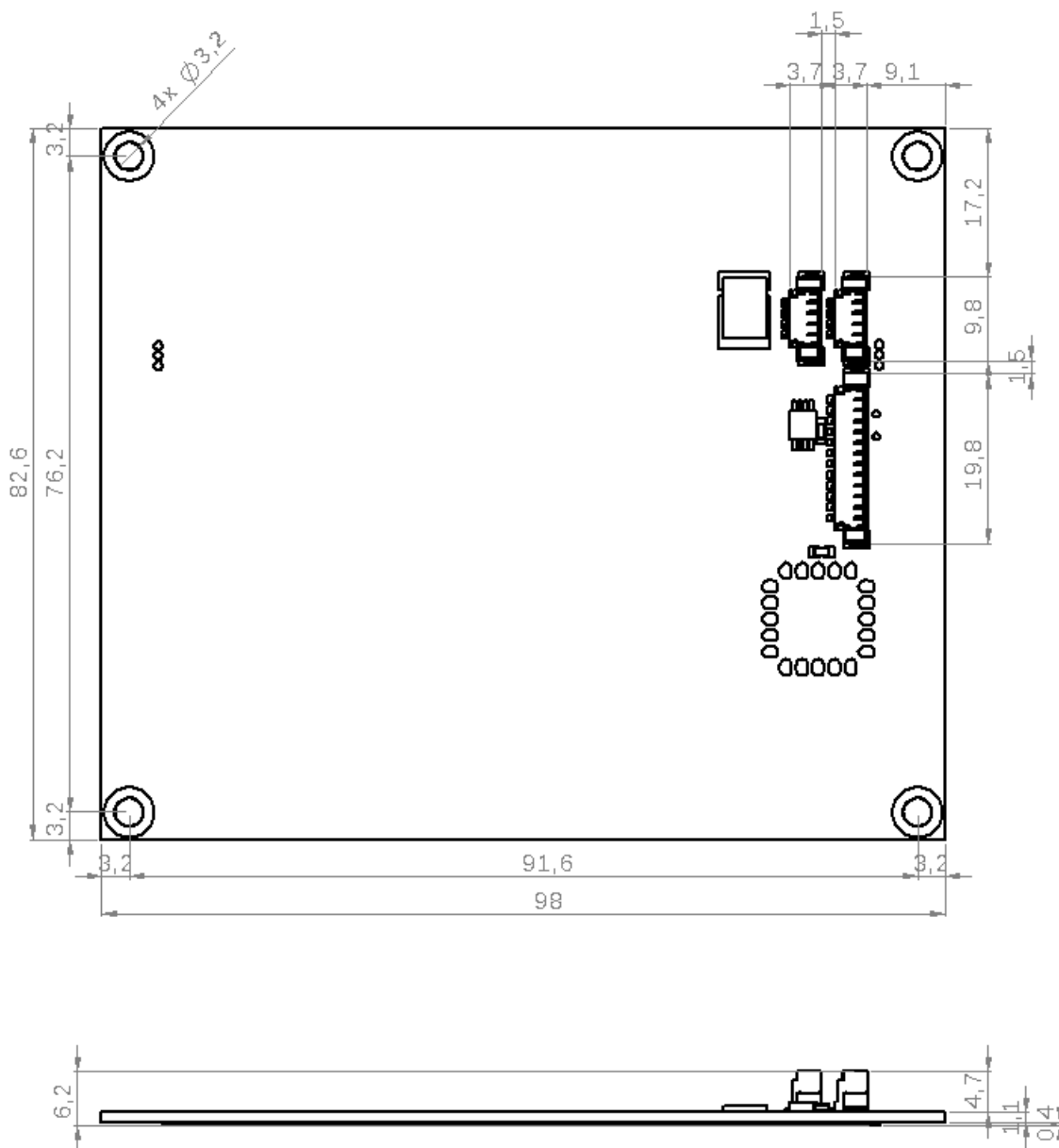

Figure 5 Example of 2U custom panel

8 Mechanical Drawing

All dimensions in mm.

8.1 P110A



8.2 P110B

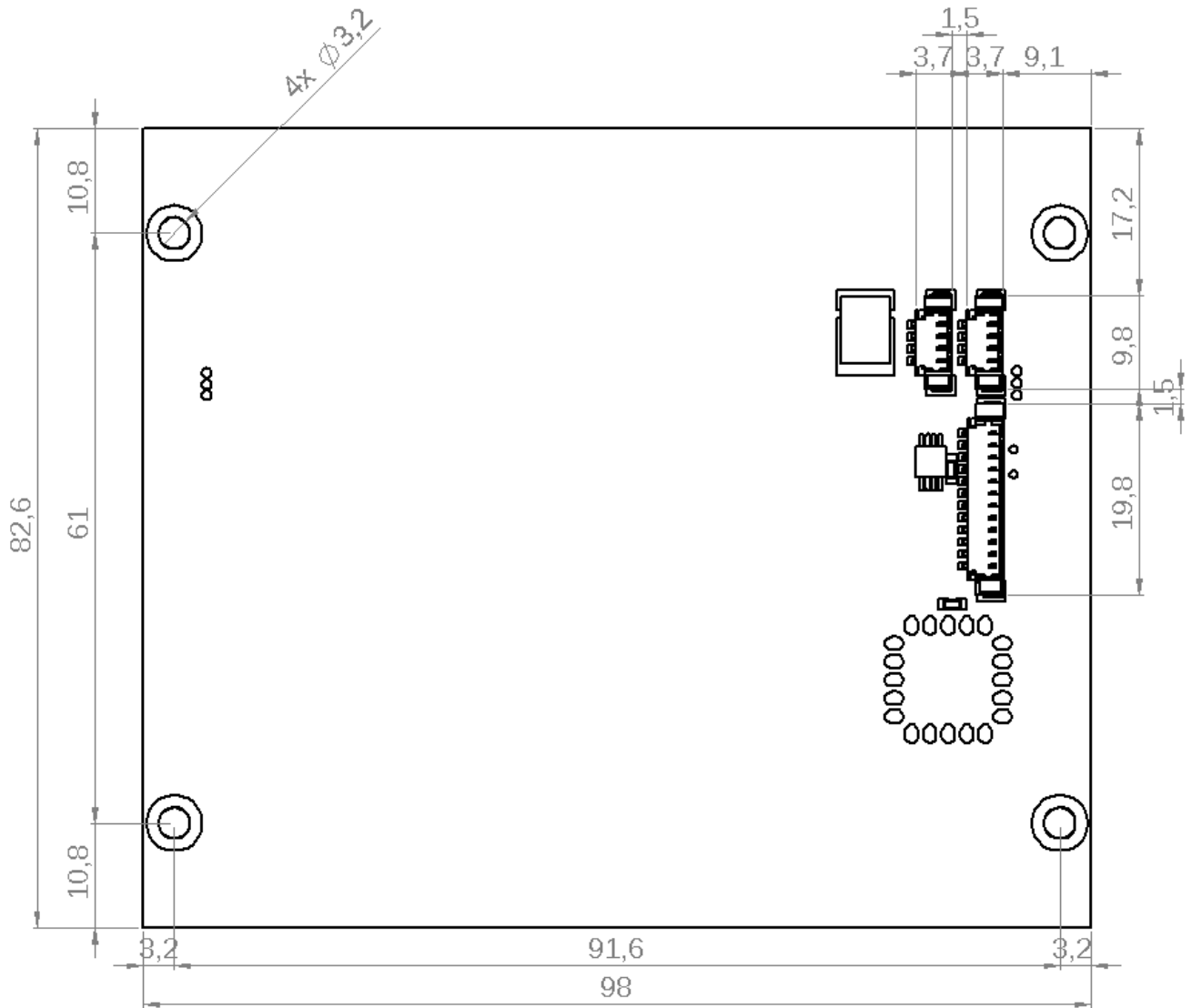

8.3 P110C

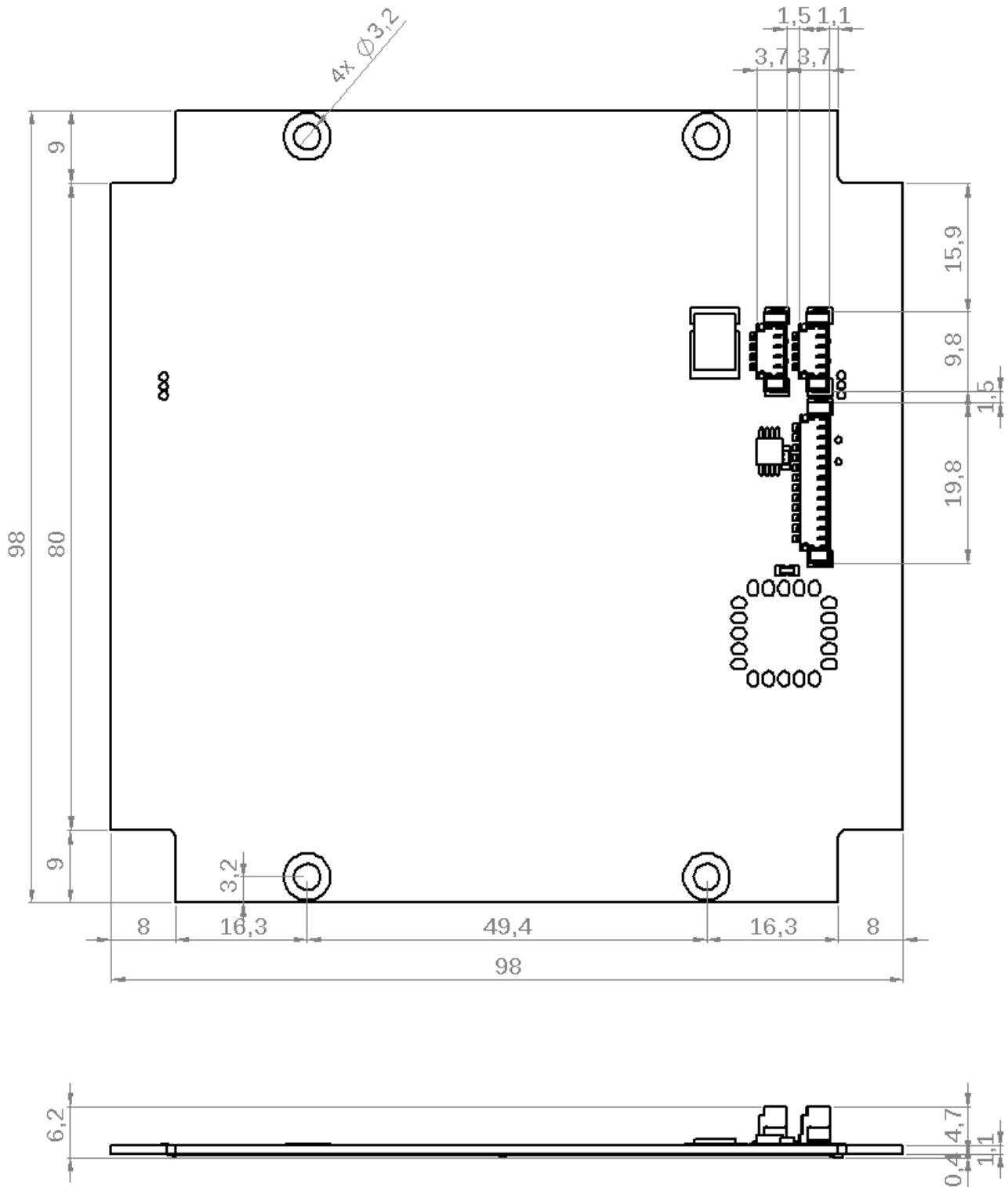

9 Disclaimer

The information in this document is subject to change without notice and should not be construed as a commitment by GomSpace. GomSpace assumes no responsibility for any errors that may appear in this document.

In no event shall GomSpace be liable for incidental or consequential damages arising from use of this document or the software and hardware described in this document.