



© GOM Space A/S 2017

NanoSense Fine Sun Sensor

Datasheet

High Precision and ultra small vector sun sensor with digital interface

Product name: NanoSense Fine Sun Sensor

Document No.: 1018157

Revision: 3.1

Author: PNN

Approved by: JECH

Approval date: 2021

Confidentiality Notice

This document is submitted for a specific purpose as agreed in writing and contains information, which is confidential and proprietary. The recipient agrees by accepting this document, that this material will not be used, transferred, reproduced, modified, copied or disclosed in whole or in part, in any manner or to any third party, except own staff to meet the purpose for which it was submitted without prior written consent.

GomSpace © 2020

1 Table of Contents

2	OVERVIEW	4
2.1	Highlighted Features.....	4
3	HOW IT WORKS.....	4
4	USAGE.....	5
5	HARDWARE LAYOUT	6
5.1	Connector Location.....	6
5.2	P1 – Connector for pin header.....	6
5.3	P2 – Connector for harness.....	7
5.4	P4 – Spring loaded connector	7
6	ABSOLUTE MAXIMUM RATINGS.....	8
7	ELECTRICAL CHARACTERISTICS	8
8	PRODUCT CHARACTERISTICS	8
9	MECHANICAL DRAWING.....	9
9.1	Recommended footprint	9
10	DISCLAIMER	10

2 Overview

The NanoSense FSS is an ultra-compact vector sun-sensor with an I²C interface designed especially for CubeSats with high ADCS requirements. The FSS comes with elevator unit for type P1 & P2, P2

2.1 Highlighted Features

- Small, light, low power
- Digital interface (I²C)
- Wide Field-Of-View
- Integrated temperature sensor
- High temperature range
- Flexible mounting (either rear or front mount)
- Flexible connector (either stack, wire or board to board)
- Delivered with calibration data.
- Mass: 2.2 g
- FSS casing size 22 x 11 x 5 mm
- Elevator size 22 x 11 x 1.3 mm

3 How it Works

The sensor is built around a quadrant diode that measures the incidence angle of the sun through a hole in the housing. The signals are filtered and sampled in a 16-bit ADC. The values are processed in a microcontroller and made available over I²C.

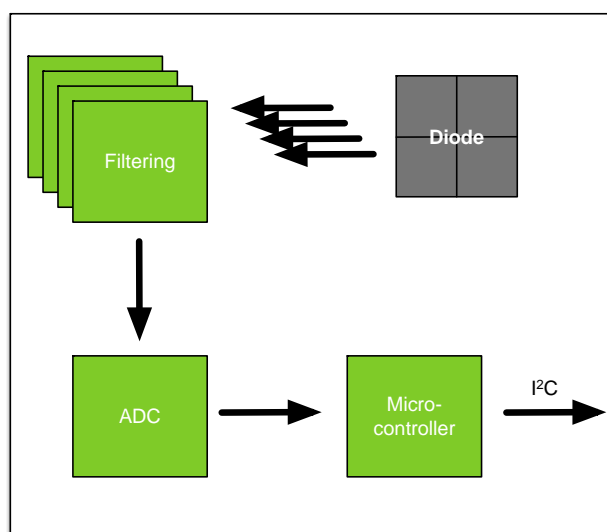

The NanoSense FSS is interfaced through I²C as a slave device. The default address is 0x05 but is configurable by I²C command.

The ADC scaling in the NanoSense FSS has been changed between two product versions. The functionality is the same, but a lower ADC value should be expected when comparing to older products.

4 Usage

Due to its small size and versatile connector system, the NanoSense FSS can be fitted into many locations on a CubeSat.

It is available with elevators that allow access to P1 & P2 connectors. It can be used to raise the sensor up to ensure that the FSS has a clear field of view. The straight elevator is necessary if the sensor is equipped with the P1 header connector as the P1 connector protrudes further out than the sensor housing. If the sensor is chosen to not include the P1 connector, then the sensor can sit flat on a mounting surface.

The FSS can be mounted internally or externally.

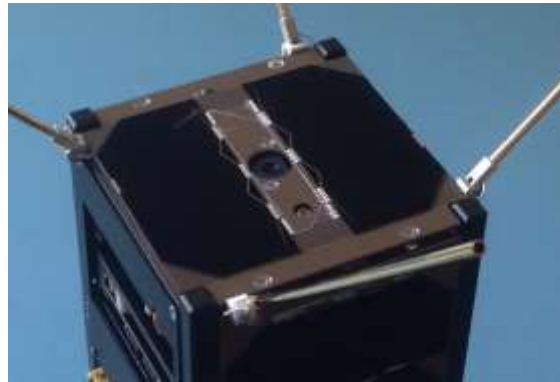

Example of external mounted FSS on an Interstage



CAD of an elevator unit

5 Hardware Layout

5.1 Connector Location

Three connector configurations are available. See the drawings below.

P2:

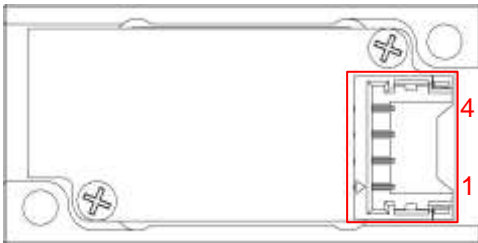

P1 + P2

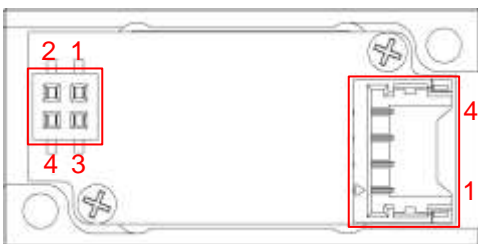

P4 (See chapter 9.1):



5.2 P1 – Connector for pin header

Samtec CLP-102-02-F-D-TR

Pin	Description
1	Vcc
2	GND
3	SDA
4	SCL

The P1 connector is used with a pin header. E.g. on the NanoUtil GSSB-A and B.

5.3 P2 – Connector for harness

Pico-EZmate 78171-0004

Pin	Description
1	Vcc
2	GND
3	SDA
4	SCL

The P2 connector is used with a wire/harness solution.

5.4 P4 – Spring loaded connector (Board to Board)

AVX – BTB00 9188 004 020 062

Pin	Description
1	Vcc
2	GND
3	SDA
4	SCL

The P4 connector is a spring-loaded connector to be used on a custom-made counterpart. See chapter 9.1 for a recommended footprint.

6 Absolute Maximum Ratings

Stresses above those listed under Absolute Maximum Rating may cause permanent damage to the FSS. Exposure to absolute maximum rating conditions for extended periods may effect the reliability.

Parameter	Description	Min	Typ.	Max	Unit
V _{cc}	Maximum supply range	-0.4		3.6	V
V _{io}	Voltage on SDA and SCL	-0.4		3.6	V
T _{op}	Operational temperature range	-40		100	°C
T _{st}	Storage temperature range	-40		125	°C

7 Electrical Characteristics

Parameter	Description	Min	Typ.	Max	Unit
V _{cc}	Supply voltage	3.0	3.3	3.6	V
I _{cc}	Supply current (Not sampling)		8	10	µA
I _{cc}	Supply current (Sampling)		3.5	4	mA
F _{i2c}	I ² C frequency		100	100	kHz

8 Product Characteristics

Parameter	Condition	Value
Accuracy (3-sigma)	FOV < 45°, No albedo*	+/- 0.5°
	FOV < 60°, No albedo*	+/- 2.0°
Sample period	Max	10 ms
Field of view	Half Angle	60°

* Albedo influence will degrade accuracy.

The influence of albedo depends on the orbit and attitude of the satellite but can generate errors >10deg.

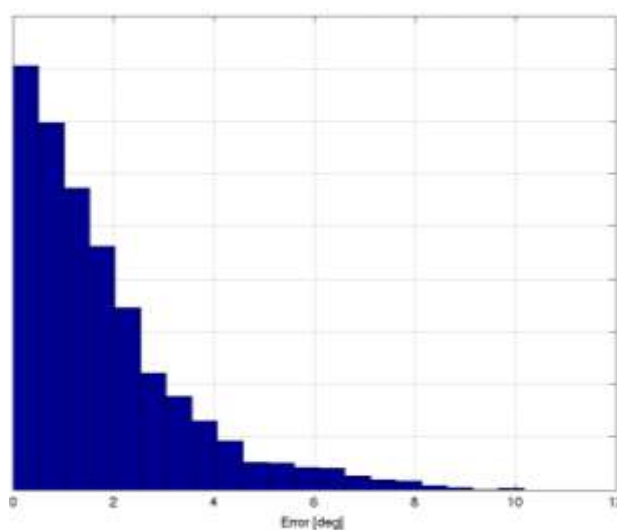
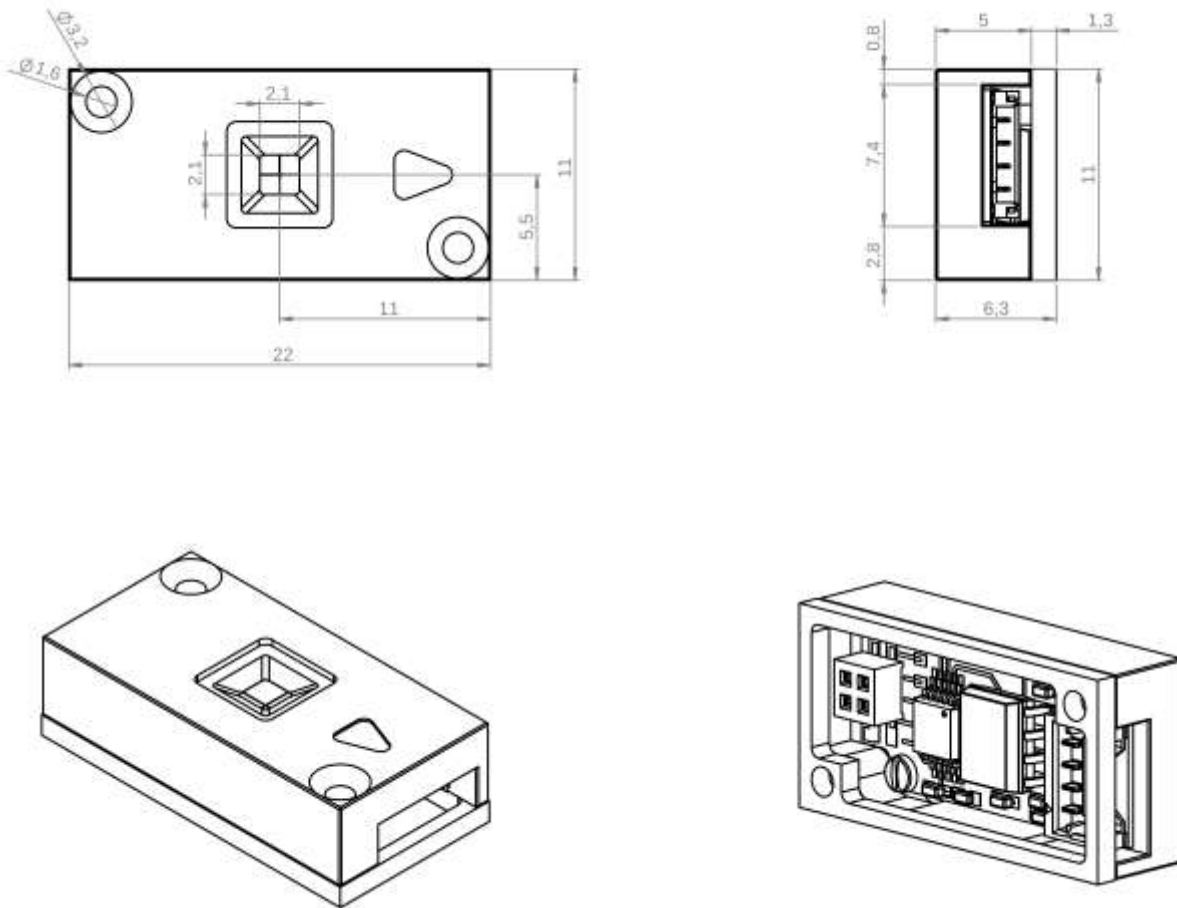

Figure 7 ISS orbit sensor error without albedo correction.

9 Mechanical Drawing

The sensor housing itself measures 22 x 11 x 5 mm with two counter-sunk 1.6 mm non-threaded holes for mounting.

All dimension in mm.



9.1 Recommended footprint

Please see the images below for the recommended footprint of the board to board connection. It is recommended to make the four pins as hard gold surface finish.

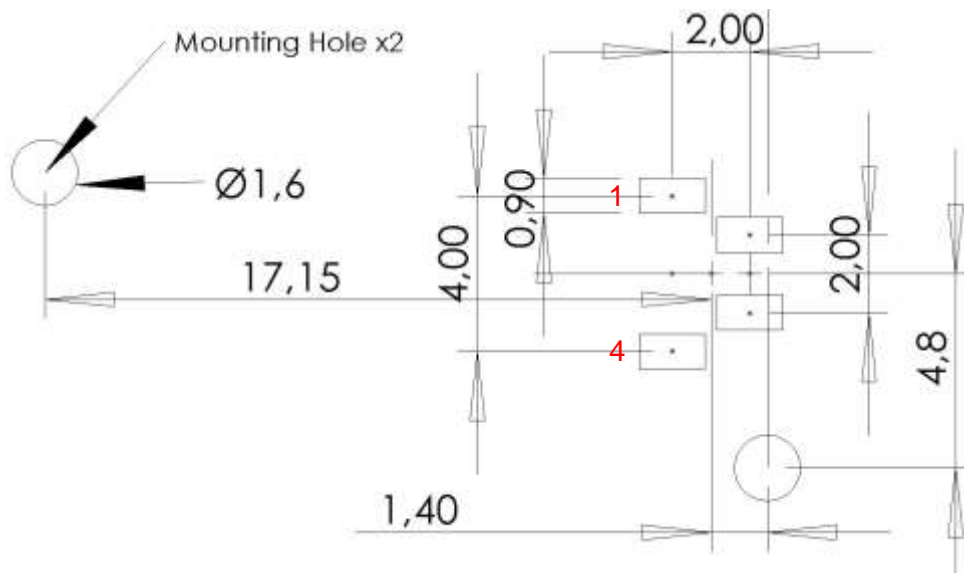

10 Disclaimer

The information in this document is subject to change without notice and should not be construed as a commitment by GomSpace. GomSpace assumes no responsibility for any errors that may appear in this document.

In no event shall GomSpace be liable for incidental or consequential damages arising from use of this document or the software and hardware described in this document.