



NanoTorque GWSW-600

Datasheet

High performance reaction wheel for 6U and 12U nano-satellites

Product name: NanoTorque GSW-600

Document No.: 1013128

Revision: 2.0

Author: KLK

Approved by: RAH

Approval date: 27 September 2018

Confidentiality Notice

This document is submitted for a specific purpose as agreed in writing and contains information, which is confidential and proprietary. The recipient agrees by accepting this document, that this material will not be used, transferred, reproduced, modified, copied or disclosed in whole or in part, in any manner or to any third party, except own staff to meet the purpose for which it was submitted without prior written consent.

GomSpace © 2018

1 Table of Contents

2	OVERVIEW	4
2.1	Highlighted Features.....	4
2.2	Block Diagram	5
3	CONNECTOR PINOUT	6
3.1	Connector Location.....	6
3.2	H1 – GomSpace Debug.....	6
3.3	H2 – Main Connector.....	6
4	ABSOLUTE MAXIMUM RATINGS.....	7
5	ELECTRICAL AND TORQUE CHARACTERISTICS PER WHEEL	7
5.1	Performance	7
5.2	Interface	7
6	PHYSICAL CHARACTERISTICS.....	8
7	MOUNTING	8
7.1	One Wheel.....	8
7.2	Pyramid Bracket Mounting.....	8
8	WHEEL PERFORMANCE	9
8.1	Torque Box	9
8.2	Current vs Speed.....	9
8.3	Dead Zone	10
9	MECHANICAL DRAWING.....	11
9.1	One Wheel.....	11
9.2	Pyramid.....	12
10	THE GSW-600 WITH GOMSPACE PRODUCTS.....	13
11	SAFETY AND PASSIVATION	13
12	DISCLAIMER	13

2 Overview

The GomSpace NanoTorque GSW-600 is a compact and high-performance reaction wheel designed and qualified for an equivalent of 3 years in-orbit operations.

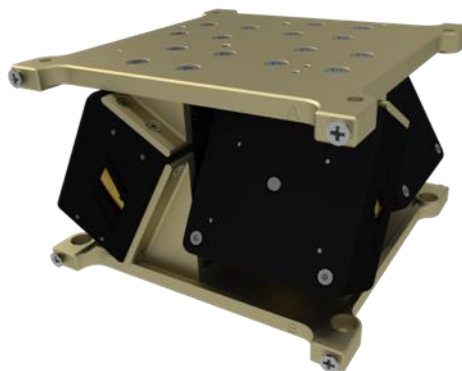
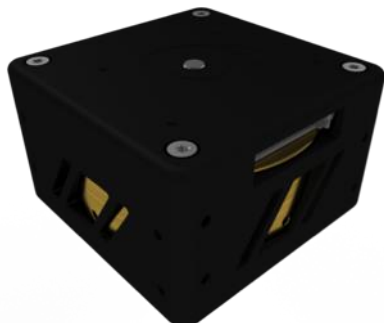

The wheel can be purchased as either single wheel without a mounting bracket or in a 4-wheel pyramid setup within a mounting bracket. The envelope of the reaction wheel is designed for allowing 4 wheels to be placed in a redundant setup within the envelope of a standard CubeSat.

The GSW-600 wheel is available in a version with SPI and I²C interface and one with CAN and I²C interface.

2.1 Highlighted Features

- 3-year design lifetime
- 2 mNm torque
- 19 mNms storage
- Long life hybrid bearings
- Precisely balanced flywheel
- Integrated electronics
- CAN, SPI or I²C interface
- Mounting from 5 sides
- Using balancing standard: ISO1940-1 to Quality G 0,4
- PCB Material: Glass/Polyimide IPC 6012C cl. 3
- IPC-A-610 Class 3 assembly

2.2 Block Diagram

Below is shown the data and power pathways.

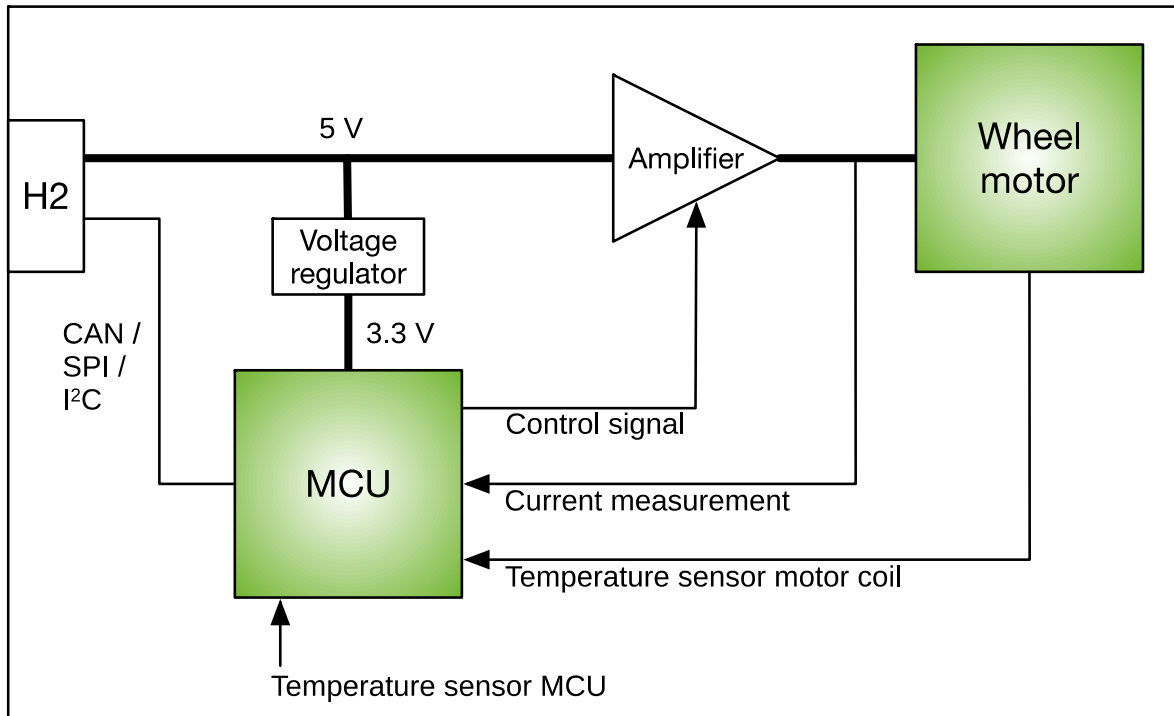

3 Connector Pinout

3.1 Connector Location

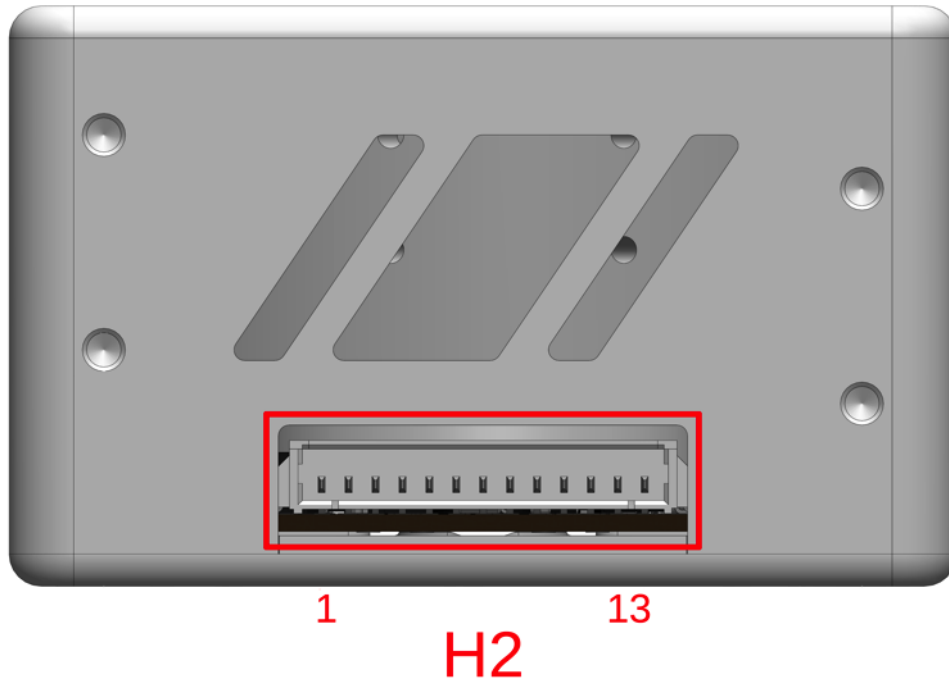

3.2 H1 – GomSpace Debug

The 5-pin connector on the opposite side is for internal use.

3.3 H2 – Main Connector

Molex PicoBlade right angle, 053261-1371

Pin	Description
1	Vcc
2	Vcc
3	GND
4	GND
5	CANH
6	CANL
7	SPI MISO
8	SPI MOSI
9	SPI CS
10	SPI SCK
11	I ² C SDA
12	I ² C SCL
13	GND

*Note that depending on model, either the CAN or the SPI interface can be used.

4 Absolute Maximum Ratings

Stresses above those listed under Absolute Maximum Rating may cause permanent damage to the device. Exposure to absolute maximum rating conditions for extended periods may affect the reliability.

Parameter	Description	Min	Typ.	Max	Unit
V _{cc}	Maximum supply range	-0.3		6.0	V
T _{op}	Operational temperature range	-40		80	°C
T _{st}	Storage temperature range	-40		85	°C

Note: There is no latch up protection in the wheel itself.

5 Electrical and Torque Characteristics per Wheel

5.1 Performance

Parameter	Condition	Min	Typ.	Max	Unit
Torque	Continuous	-1.5		1.5	mNm
Speed	Maximum	-6000		6000	rpm
Speed	At max torque	-3500		3500	rpm
Momentum	At max speed		19		mNms
Supply voltage		4.9	5	5.1	V
Supply current	At maximum torque			500	mA
Supply current	At 4500 rpm (zero torque)		60		mA
Control accuracy	Speed control		0.5		rpm

5.2 Interface

Parameter	Condition	Min	Typ.	Max	Unit
CAN speed				1,000,000	bps
SPI speed				250,000	bps
I ² C speed				400,000	bps
I/O voltage	CAN / I ² C / SPI		3.3	3.4	V
CAN termination			120		Ω
I ² C pull-up			200		kΩ

6 Physical Characteristics

One Wheel

Description	Value	Unit
Mass	180	g
Size	44.0 x44.0 x 27.0	mm
Flywheel inertia	300	gm ²

Pyramid

Mounting bracket and 4 wheels.

Description	Value	Unit
Mass	940	g
Size	95.0 x 95.0 x 61.6	mm

7 Mounting

7.1 One Wheel

On five sides of the casing of one wheel, there are 4 holes that are designed to be used for mounting. Use a M2.0 screw. No screw holes in the lid of the unit.

7.2 Pyramid Bracket Mounting

This bracket is designed for the GomSpace 6U structure, but can be used with other structures. The pyramid comes unassembled, for easy access to the individual wheel connectors.

The bracket can be mounted as part of a PC104 stack (3 mm rods) or directly on the GomSpace 6U structure (2.5 mm screws).

Further holes on the top and bottom can be used for mounting smaller units (2.5 mm screws), like e.g. a gyroscope.

8 Wheel Performance

8.1 Torque Box

The plot shows the wheel performances for different torque levels. The dashed line indicates the dead zone which is shown on its own plot.

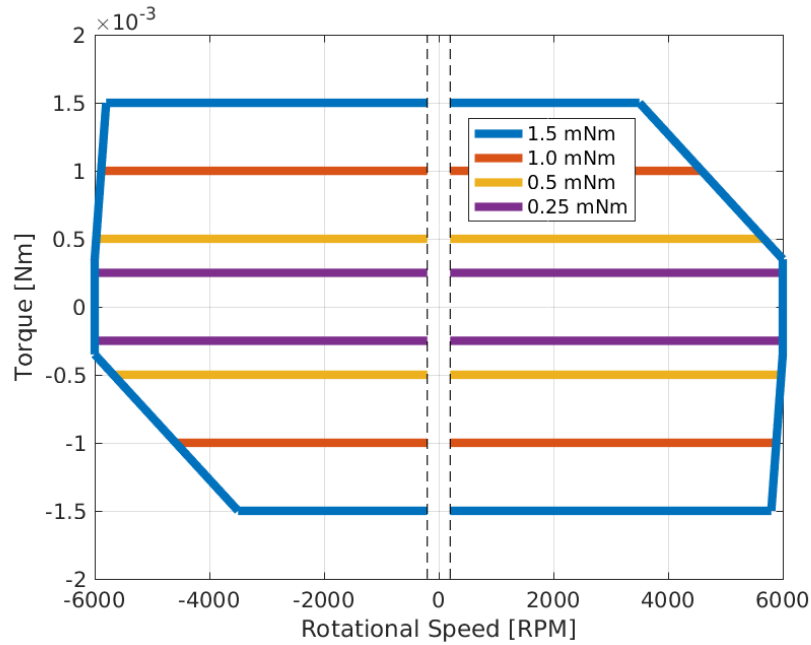

8.2 Current vs Speed

The plot shows the current consumption at different torque levels.

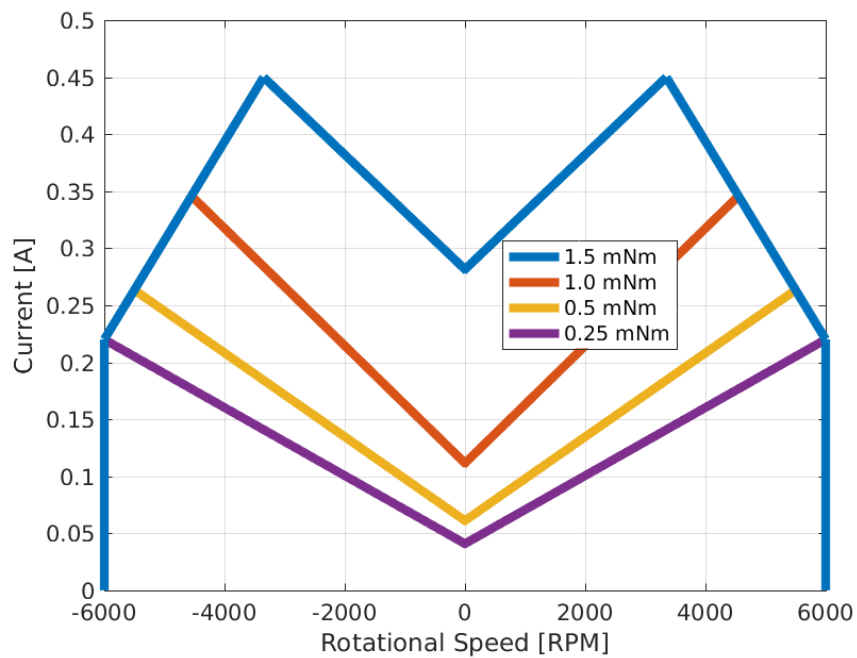

8.3 Dead Zone

The plot below shows the behaviour of the reaction wheel through the dead zone at different torque levels. The dead zone is caused by static friction and is framed by the dashed lines. To ensure proper control it must be avoided to operate the wheel within this zone.

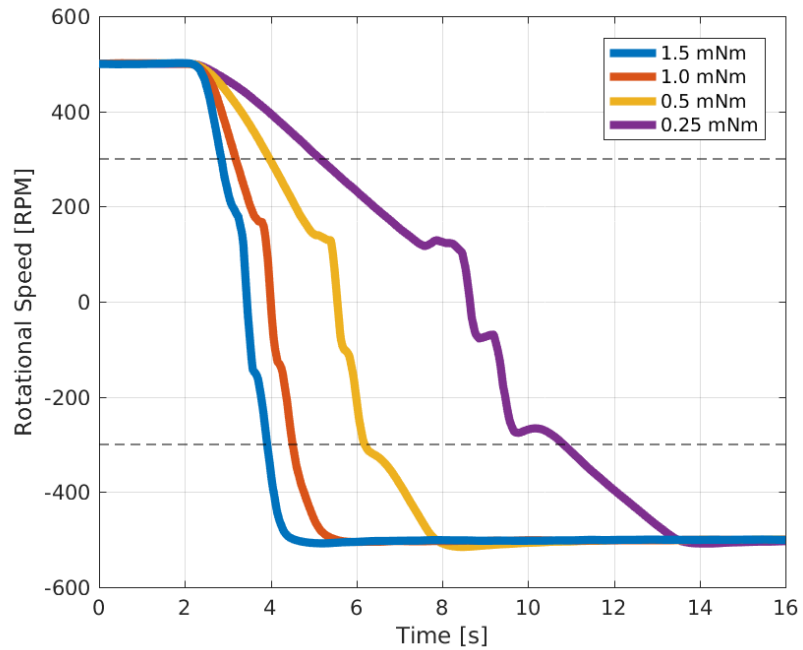

9 Mechanical Drawing

All dimensions in mm.

9.1 One Wheel

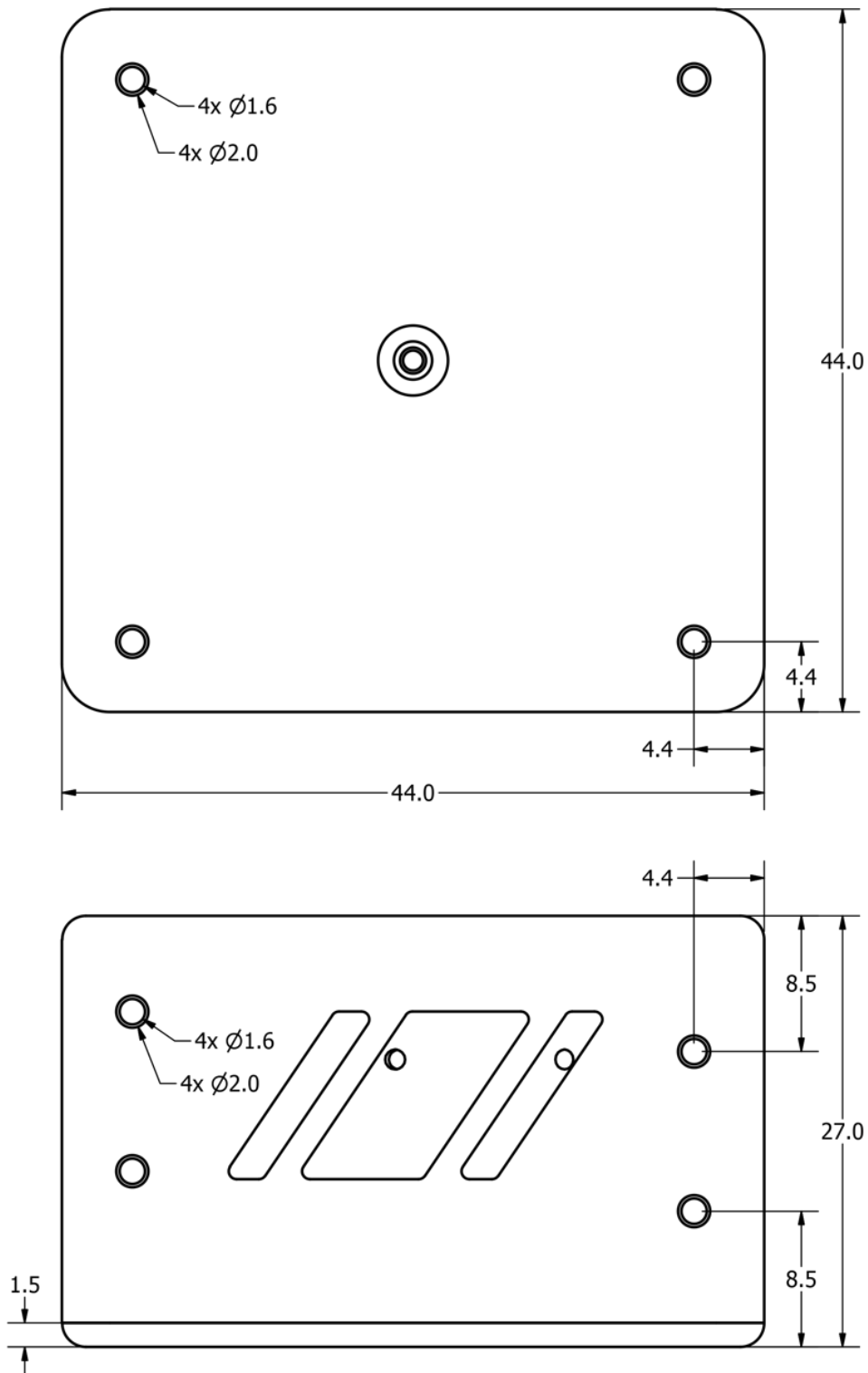

9.2 Pyramid

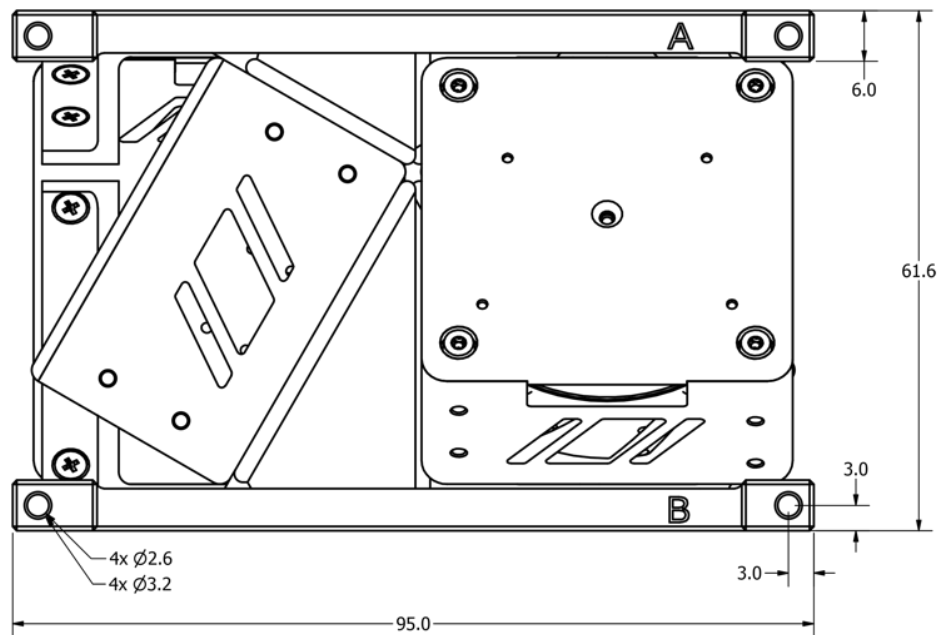
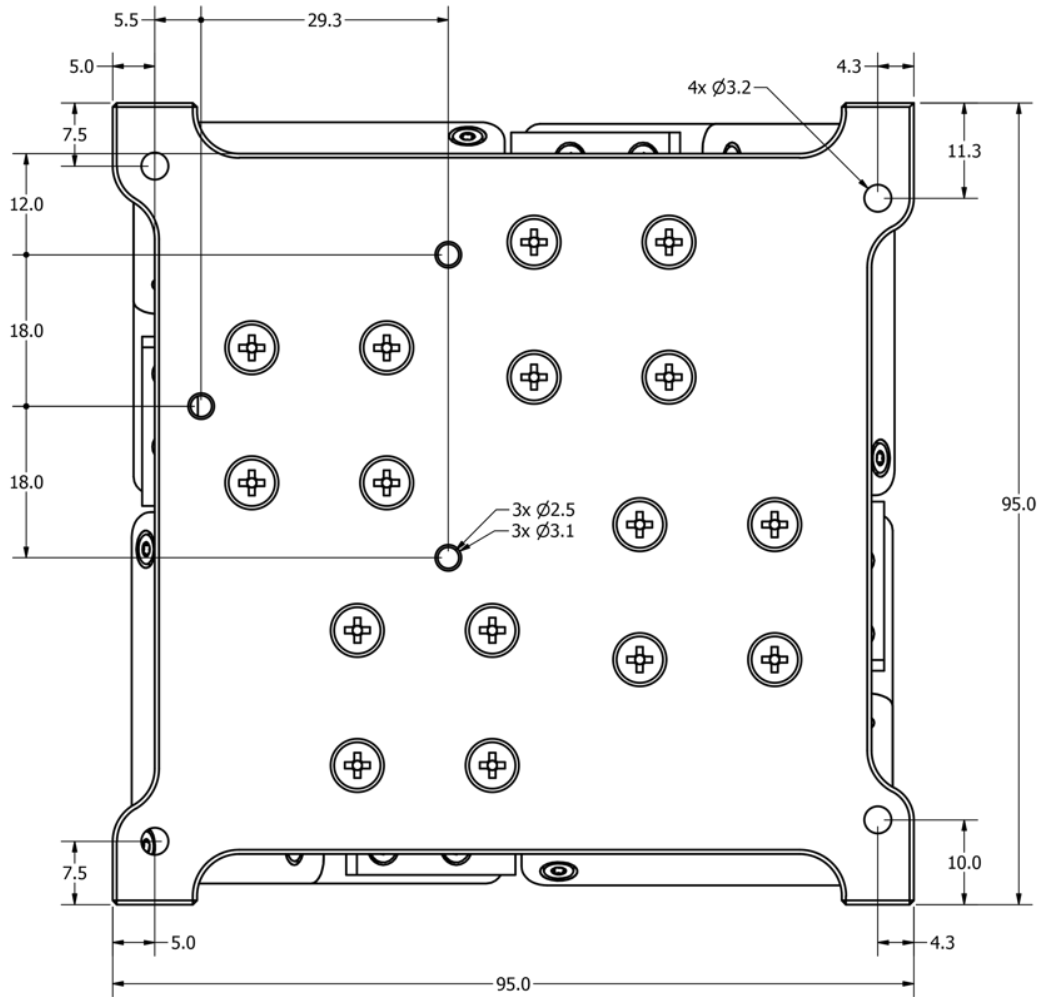

10 The GSW-600 with GomSpace Products

The GSW-600 is part of a GomSpace ADCS solution. The center unit is the NanoDock ADCS-6 PCB mounted with a NanoMind A3200 and a GPS. All peripheral units are connected to the NanoDock.

Below is shown an example with GomSpace products. View the individual datasheets for further info.

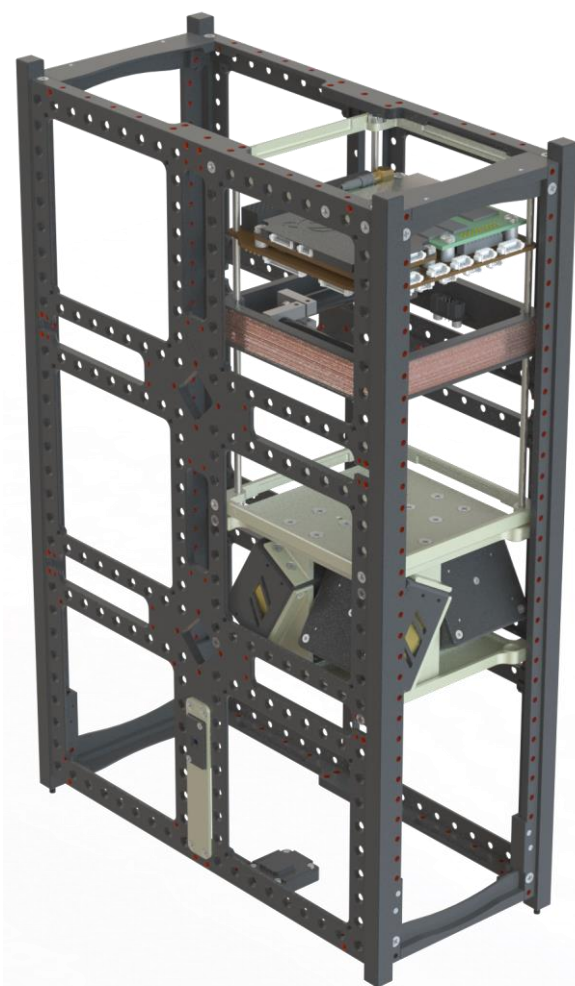

NanoDock ADCS-6 with NanoMind A3200 and GPS

NanoTorque GST-600 magnetorquer

NanoTorque GSW-600 reaction wheel

NanoStructure 6U with a Fine Sun Sensor

NanoSense M315 magnetometer

11 Safety and Passivation

The GSW-600 reaction wheel is designed to be inherently safe and no command or failure can cause a mechanical breakup of it. To passivate the GSW-600 switch off the reaction wheel by removing power from it.

12 Disclaimer

The information in this document is subject to change without notice and should not be construed as a commitment by GomSpace. GomSpace assumes no responsibility for any errors that may appear in this document.

In no event shall GomSpace be liable for incidental or consequential damages arising from use of this document or the software and hardware described in this document.