



NanoMind A3200 (200284)

NanoMind A3200 PWM from VAUX (103409)

Datasheet

On-board Computer System for mission critical space applications

Product name: NanoMind A3200

Document No.: 1006901

Revision: 2.0

Author: PNN

Approved by: TIM

Approval date: 04-04-2025

Confidentiality Notice

This document is submitted for a specific purpose as agreed in writing and contains information, which is confidential and proprietary. The recipient agrees by accepting this document, that this material will not be used, transferred, reproduced, modified, copied or disclosed in whole or in part, in any manner or to any third party, except own staff to meet the purpose for which it was submitted without prior written consent.

GomSpace © 2025

1 Table of Contents

2	OVERVIEW	4
2.1	Highlighted Features.....	4
2.2	Block diagram	5
2.3	Functional Description	5
2.3.1	Microcontroller	5
2.3.2	Two I ² C Interfaces	5
2.3.3	CAN Interface	5
2.3.4	3-Axis Magnetometer and Gyroscope	6
2.3.5	3-PWM Bidirectional Outputs.....	6
2.3.6	Connector for GomSpace Sensor Bus	6
2.3.7	ADC and GPIO Channels	6
2.3.8	RTC with 32 kB Nonvolatile Storage	6
2.3.9	SDRAM	6
2.3.10	PPS.....	6
3	HARDWARE LAYOUT, CONNECTORS AND PIN OUT	7
3.1	A3200 Top	7
3.1.1	P1 - Picoblade USART (debug) Connector	7
3.1.2	P2 - Picoblade Connector for JTAG	8
3.1.3	P6 - Picoblade Connector with PWM outputs.....	8
3.1.4	P7 - Picoblade Connector with I ² C and VBAT	8
3.2	A3200 Bottom	9
3.2.1	X1 and X3 - FSI Main Connectors	9
4	MCU MAPPING	10
5	GENERAL CHARACTERISTICS	11
6	ABSOLUTE MAXIMUM RATINGS.....	12
7	PHYSICAL CHARACTERISTICS.....	12
8	ENVIRONMENT TESTING	12
9	DEBUG INTERFACE.....	13
10	SOFTWARE DEVELOPMENT	13
11	MECHANICAL DRAWING.....	14
12	DISCLAIMER	14

2 Overview

The NanoMind A3200 (A3200) contains three main parts.

- The A3200 on-board computer (OBC) is designed as an efficient system for space applications with limited resources, such as e.g. for CubeSat or nano-satellite missions.
- A 3-Axis magnetometer and coil- drivers that can be used to implement attitude control based on magnetic sensing and actuation.
- A 3-Axis gyroscope used for attitude control.

Its main interface to other subsystems is CAN and I²C. For storage, the board carries a 128 MB NOR serial flash. The RTC chip on the board also functions as a processor companion while 32 kB of FRAM provides non-volatile storage.

Beside the I²C controller for the main bus the board also has an extra I²C controller that can be used to interface to external I²C components. For interfacing with SPI devices, the board has one external connection with three chip selects. Furthermore, it has 8 inputs to an ADC. If needed, the ADC inputs can also be used as GPIO.

The form factor of the A3200 fits on the GomSpace NanoDocks, which makes it possible to fit both the A3200 and another daughterboard next to each other in the same space as a standard OBC would require.

2.1 Highlighted Features

- High-performance AVR32 MCU with advanced power saving features
- Clock frequency from 8 MHz to 64 MHz
- 512 KB build-in flash
- IEEE 754 FPU
- Wide range for clocks speeds with build-in PLL
- Multiple CSP data interfaces: I²C, UART, CAN-Bus
- 128 MB NOR flash (On two dies of 64 MB each)
- 32 kB FRAM for persistent configuration storage
- 32 MB SDRAM
- RTC clock
- On-board temperature sensors
- 8 external ADC channels that also can be used as GPIO
- External SPI with 3 chip selects
- Attitude stabilization system
 - 3-Axis magneto resistive sensor
 - 3-Axis gyroscope
 - 3 bidirectional PWM outputs with current measurement
 - I²C interface for GomSpace Sensor Bus (GSSB)
- New compact daughter-board form-factor (compatible with GomSpace motherboards)
- Operational temperature: -30 °C to +85 °C
- 2 x 20-position hard-gold plated FSI one-piece connector
- UART console interface for easy use in lab setup
- PCB material: Glass/Polyimide 4+4 twin stack ESA ECSS-Q-ST-70-11-C
- IPC-A-610 Class 3 assembly

2.2 Block diagram

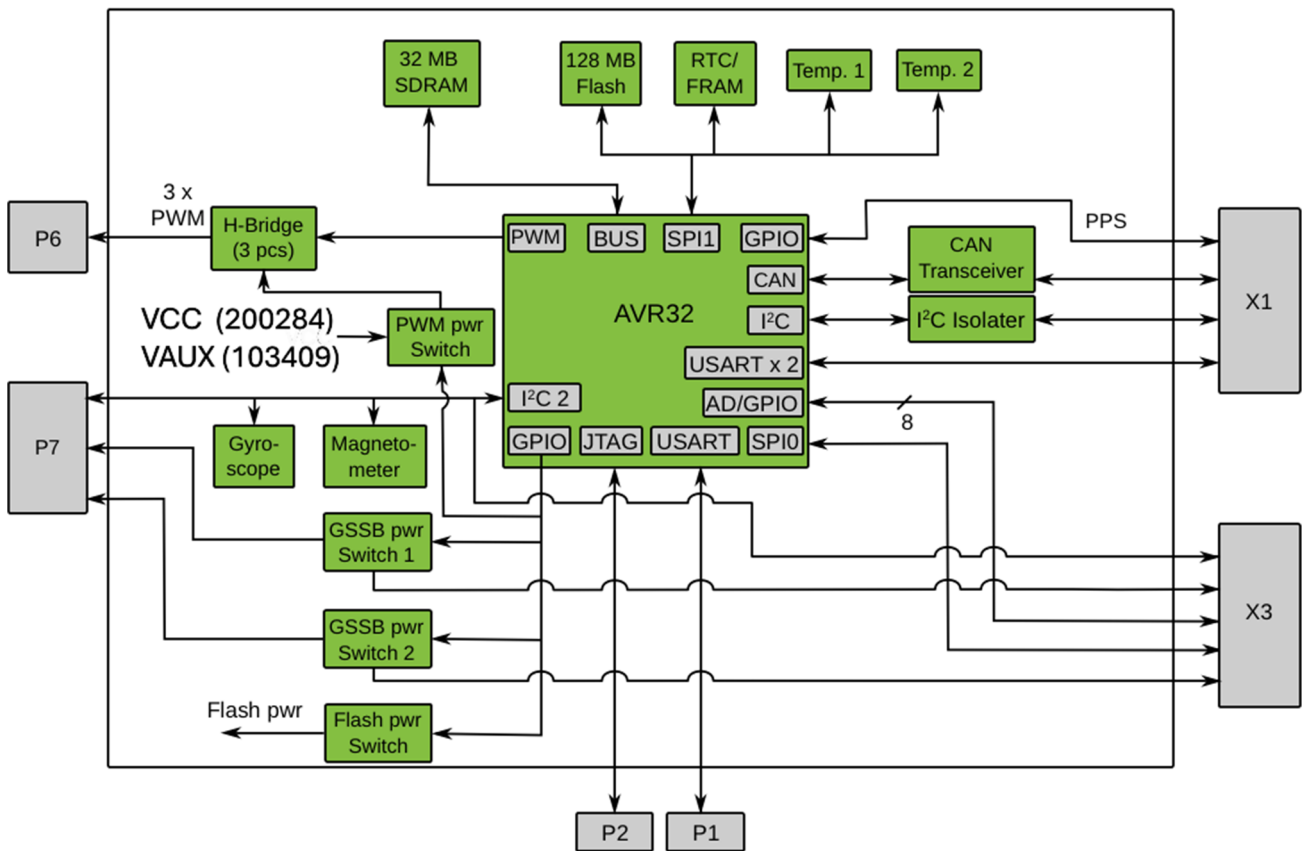

Figure 1: Block diagram of the A3200 board.

2.3 Functional Description

2.3.1 Microcontroller

The A3200 is based on an Atmel AT32UC3C MCU. This is a high performance 32-bit RISC architecture with advanced power saving features to both facilitate tasks with a high computational demand and tasks where the MCU is idle most of the time. For applications as ADCS the MCU has floating point support that is based on IEEE 754 floating point standard.

2.3.2 Two I²C Interfaces

A3200 has two I²C buses supporting bidirectional data transfer between masters and slaves, multi-master bus, arbitration between simultaneously transmitting masters without corruption of serial data on the bus. Serial clock synchronization allows devices with different bit rates to communicate via one serial bus and is used as a handshake mechanism to suspend and resume serial transfer.

2.3.3 CAN Interface

One of the main interfaces of the A3200 to communicate with other subsystem hardware is a CAN bus interface. The Controller Area Network (CAN) is a serial communications protocol that supports distributed real-time control with a high level of security. The maximum bus speed is 1 Mbits/s.

The A3200 uses the SN65HVD230 as a CAN transceiver. Designed for operation in harsh environments, this device features cross-wire protection, loss-of-ground and over-voltage protection, over-temperature protection, as well as wide common mode range. This device provides different modes of operation: high-speed, slope control, and low-power modes.

2.3.4 3-Axis Magnetometer and Gyroscope

The A3200 includes a 3-Axis magnetometer to sense Earth's magnetic field, the HMC5843 from Honeywell. The device is based in the Honeywell's Anisotropic Magnetoresistive (AMR) technology. The sensor features precision in-axis sensitivity and linearity, and its solid-state construction with very low cross-axis sensitivity designed to measure both direction and magnitude of Earth's magnetic field, from 10 micro-gauss to 4 gauss.

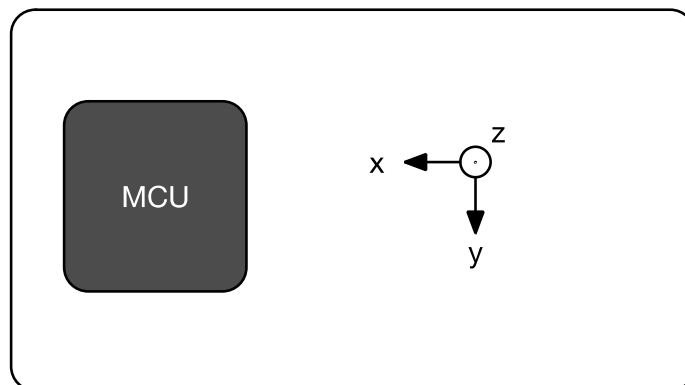

Figure 2 A3200 top view. Magnetometer and gyro directions

Beside the magnetometer the board also includes a 3-Axis gyroscope, the MPU-3300 from InvenSense. This gyro has a low power consumption of less than 10 mW and an operating temperature range of -40 °C to +105 °C. It offers a full-scale range up to ± 450 degrees per second and a bias instability of 15 degrees/hour.

Both the magnetometer and the gyroscope interface to the MCU via the I²C2 bus using a driver included in the software library.

2.3.5 3-PWM Bidirectional Outputs

The A3200 has 3 bidirectional outputs from 3 H-bridge drivers designed to be controlled by a PWM output from the microcontroller. The main purpose of these bidirectional outputs is to be used for external magnetorquers to implement attitude control. It is possible to switch the power to the PWM driver, they also support current measurements. On the A3200 (200284) PWM output are supplied from 3.3v VCC, On the A3200 (103409) PWM output are supplied from VAUX.

2.3.6 Connector for GomSpace Sensor Bus

The A3200 has a connector with switchable power and I²C2 bus which this can be used together with GomSpace sun sensors and interstages panels.

2.3.7 ADC and GPIO Channels

To sample external analog values the board supplies 8 ADC channels in one of the main connectors. These 8 pins can also be configured to be GPIO instead of ADC inputs.

2.3.8 RTC with 32 kB Nonvolatile Storage

For timekeeping and storage of nonvolatile data the board includes a FM33256B processor companion from Cypress. This chip includes RTC, watch dog, brown-out detect and 256 Kb ferroelectric random-access memory (FRAM) which supports 10^{14} read/write cycles.

2.3.9 SDRAM

For applications that need more ram than what is embedded in the MCU the board also has 32 MB of SDRAM connected to the microcontroller.

2.3.10 PPS

A Pulse Per Second (PPS) signal on this input can trigger an event in the processor. This pin can also be configured to a GPIO pin.

3 Hardware Layout, Connectors and Pin Out

3.1 A3200 Top

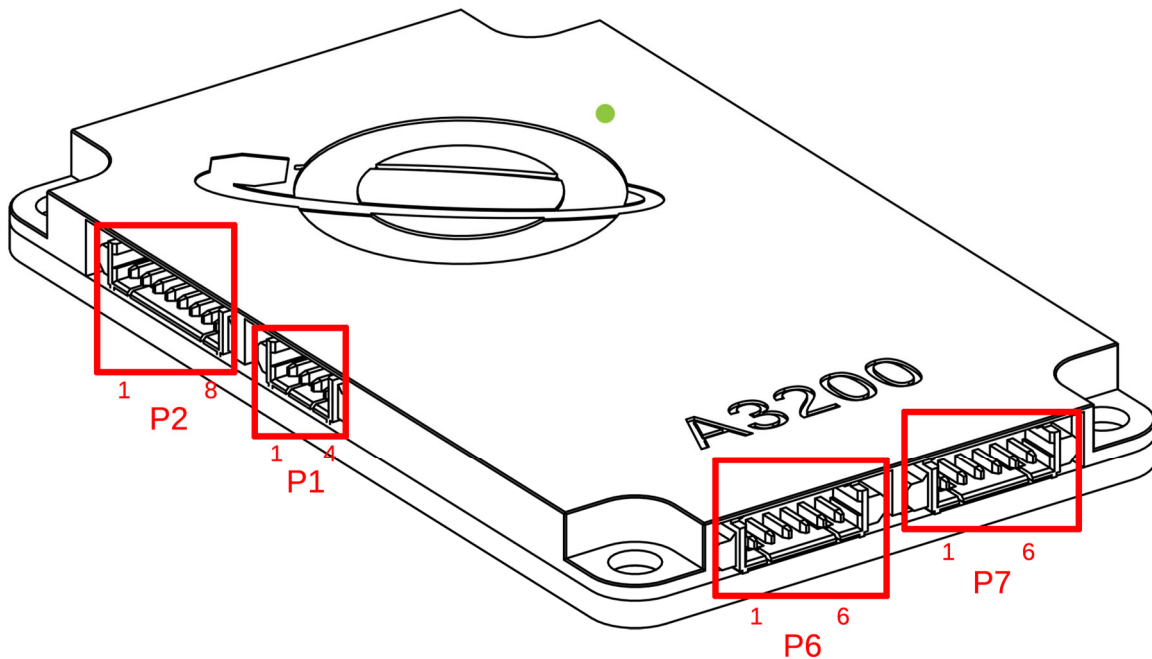

● Temperature sensors – Next to MCU

3.1.1 P1 - Picoblade USART (debug) Connector

Molex PicoBlade 53261-0471

The debug USART is designed for easy access to the A3200 configuration and makes it possible to do factory checkout of standalone modules without a motherboard.

Warning: please only supply the NanoMind A3200 from a single power-supply. If you have the debug USART connected to a PC and power is coming from the motherboard, you must disconnect pin 2 in the debug connector. Take special care about grounding when connecting a laptop with an external switch-mode power supply as these tend to produce a high common-mode noise, which can damage the PCB's if not grounded correctly. Serial port settings are 500000 baud and 8n1.

Pin	Description
1	GND
2	VCC_OBC
3	USART2 RX (Data to A3200)
4	USART2 TX (Data from A3200)

3.1.2 P2 - Picoblade Connector for JTAG

Molex PicoBlade 53261-0871

The JTAG interface is used for software upload only.

Pin	Description
1	TDO
2	TCK
3	TMS
4	TDI
5	RESET_N
6	RESET_N
7	VCC_OBC
8	GND

3.1.3 P6 - Picoblade Connector with PWM outputs

Molex PicoBlade 53261-0671

Outputs for driving magnet torques are located in connector P6. The PWM drivers in the MCU control these outputs and they are setup by default, but they can be configured different in the SW.

Pin	Name	Description
1	MT Z A	POS
2	MT Z B	NEG
3	MT Y A	POS
4	MT Y B	NEG
5	MT X A	POS
6	MT X B	NEG

3.1.4 P7 - Picoblade Connector with I²C and VBAT

Molex PicoBlade 53261-0671

The P7 connector can be used together with GomSpace interstages and Fine Sun Sensors. The I²C bus in the connector is also used on the board for the magnetometer and the gyroscope and it can be connected to external devices. Also found in the connector is two switchable outputs that are connected to the board VCC. If an external device needs battery voltage it can be taken from this connector. (This is not available on product 103409 A3200 PWM on AUX due to max 6v on PWM.)

Pin	Name	Description
1	VAUX	Normally connected to VBAT and used for antenna deployment (this is not allowed on product 103409 A3200 PWM supplied from VAUX.)
2	GSSB_VCC2	Switchable output from board
3	GND	
4	GSSB_VCC	Switchable output from board
5	SCL2	I ² C clock
6	SDA2	I ² C data

3.2 A3200 Bottom

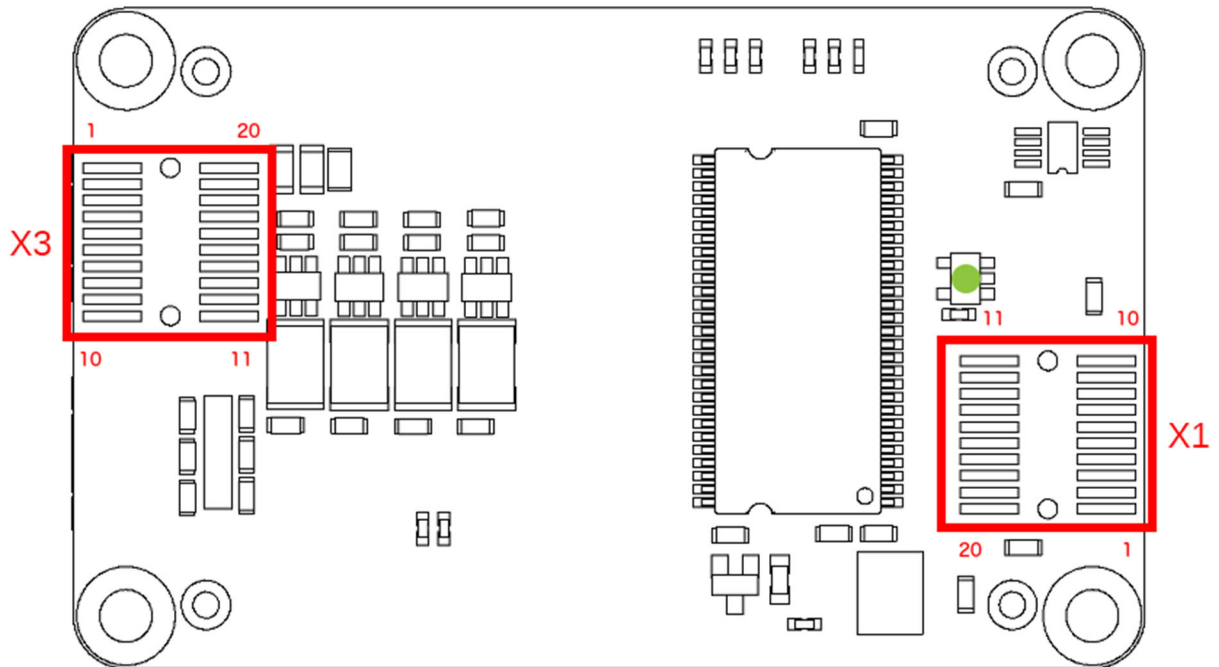

- Temperature sensors – next to RAM

3.2.1 X1 and X3 - FSI Main Connectors

The main connectors are built into the PCB as two 20-position hard-gold plated FSI one-piece connectors. The motherboard connector is a SAMTEC-FSI-110-D. The X1 and X3 connectors are connected to the NanoDock FSI's. Pressing the gold-plated PCB onto the connector and fastening the PCB to the motherboard using 4 screws connect the modules. The alignment is done with two plastic pins that fit in the holes on the A3200 module. The overall stacking height between the motherboard and the A3200 module's underside is 3.0 mm. A 3.0 mm spacer must therefore be used in each of the four corners of the A3200.

See chapter 4 for mapping descriptions to the MCU pin numbers.

Pin	Description for X3	Pin	Description for X1
1	GND	20	GND
2	GND	19	GND
3	VCC_OBC	18	VCC_OBC
4	VCC_OBC	17	VCC_OBC
5	I ² C SCL	16	VAUX
6	I ² C SDA	15	VAUX
7	CAN high	14	PPS
8	CAN low	13	Not Connected
9	USART4 RX (data to A3200)	12	USART1 RX (data to A3200)
10	USART4 TX (data from A3200)	11	USART1 TX (data from A3200)

Pin	Description for X3	Pin	Description for X3
1	I ² C 2 SDA	20	SPI0_SCK
2	I ² C 2 SCL	19	SPI0_MOSI
3	GSSB VCC	18	SPI0_MISO
4	GND	17	SPI0_CS0
5	GSSB VCC2	16	SPI0_CS1
6	VAUX	15	SPI0_CS2
7	AD0	14	AD4
8	AD1	13	AD5
9	AD2	12	AD6
10	AD3	11	AD7

4 MCU Mapping

Consult the Atmel AT32UC3C0512C MCU Package LQFP144 datasheet to compare pins.

A3200	Connector	Connector	MCU	
Description	ID	PIN	Pin	Mnemonic
I ² C SCL	X1	5	74	PC03 (through isolator)
I ² C SDA	X1	6	73	PC02 (through isolator)
CAN H	X1	7	7	PB04 - CAN RX (through transceiver)
CAN L	X1	8	8	PB05 - CAN TX (through transceiver)
USART4 RX	X1	9	82	PC09
USART4 TX	X1	10	81	PC08
USART1 TX	X1	11	20	PB17
USART1 RX	X1	12	19	PB16
GPIO	X1	14	143	PB02
I ² C 2 SDA	X3	1	79	PC06
I ² C 2 SCL	X3	2	80	PC07
AD0	X3	7	21	PA04
AD1	X3	8	22	PA05
AD2	X3	9	23	PA06
AD3	X3	10	24	PA07
AD4	X3	14	25	PA08
AD5	X3	13	26	PA09
AD6	X3	12	27	PA10
AD7	X3	11	28	PA11
SPI_CS2	X3	15	72	PC01
SPI_CS1	X3	16	17	PB14
SPI_CS0	X3	17	16	PB13
SPI0_MISO	X3	18	14	PB11
SPI0_MOSI	X3	19	13	PB10
SPI_SCK	X3	20	15	PB12

5 General Characteristics

Parameter	Condition	Min	Typ.	Max	Unit	
VCC_OBC	Supply voltage	3.2	3.3	3.4	V	
Clock Frequency		8	32	64	MHz	
Operating temperature		-30		85	°C	
Current consumption, VCC_OBC = 3.3 V	All clocks 64 MHz, MCU idle _{1,2}		42		mA	
	All clocks 32 MHz, running ADCS _{1,2}		45		mA	
	All clocks 32 MHz, MCU idle _{1,2}		33		mA	
	All clocks 8 MHz, MCU idle _{1,2}		23		mA	
	Additional Current Consumption:					
	Gyroscope on			3.6		mA
	Magnetometer (10 Hz averaged)			0.9	18	mA
Power consumption VCC_OBC	External flash read			200	mA	
	External flash Standby		70		µA	
			0.17	0.9	W	
PWM output X,Y,Z - Supply voltage VCC_OBC VAUX (PWM from VAUX) - Total current output - Current output one Ch - Frequency - Duty cycle resolution	X+Y+Z X or Y or Z	0	3.3		V	
				6	V	
				1	A	
				1	A	
			16	250	kHz	
					bit	
Magnetometer - Field range - Measurement time - Resolution - SNR		-4		4	Gauss	
			10		ms	
			7		mG	
			70		dB	
Gyroscope - Full-Scale Range - ADC Word Length - Nonlinearity - Cross-Axis Sensitivity			225	450	°/s	
			16		bit	
			0.2		%	
			±2		%	
I²C - Voltage - Bit-rate		0		3.3	V	
			400	400	kbit/s	
CAN - Bus voltages - Bit-rate		-4		16	V	
				1000	kbit/s	
SPI - Voltage		0		3.3	V	
ADC - Reference voltage - Voltage range				2.5	V	
		0		2.5	V	
GSSB Power channels	Supply current @3.3 V			114	mA	

1. Magnetometer, gyroscope, flash and SDRAM enabled
2. FreeRTOS idle call to sleep mode Frozen.

6 Absolute maximum ratings

Stresses above those listed under Absolute Maximum Ratings may cause permanent damage to the A3200. Exposure to absolute maximum rating conditions for extended periods may affect the reliability.

Symbol	Description	Min.	Max.	Unit
I	Supply current	-	1	A
T _{amb}	Operating Temperature	-30	85	°C
T _{stg}	Storage Temperature	-30	85	°C
V _{io}	Voltage on I ² C/USART/JTAG pins	-0.3	3.6	V

7 Physical Characteristics

Description	Value	Unit
Mass including shield	24	g
Size	65 x 40 x 7.1	mm

8 Environment Testing

To simulate the harsh conditions of launch and space, the A3200 has been exposed to a number of environment tests. For detailed information about the tests please contact GomSpace.

The A3200 has flown successfully on several satellites and performed perfectly.

9 Debug Interface

The debug interface is a USART that uses the GomSpace Shell (GOSH) to present a console-like interface to the user. GOSH is a general feature present on all GomSpace products. To read more about GOSH please go to www.gomspace.com

The console can be used during checkout of the A3200 to send commands and set parameters of the A3200. Telemetry and housekeeping parameters can also be monitored. Here is a short list of some of the features of the debug interface:

- Inspect CSP traffic (incoming and outgoing)
- Test command for board (Switch power channels, read gyroscope and magnetometer, set PWM outputs, etc.)
- Commands for other GomSpace subsystems as NanoPower EPS, NanoCom radio and GomSpace GSSB sensor devices such as NanoSense Fine Sun Sensor.

These features make it easy to test the functionality and connections to the A3200 before it is loaded with custom software.

The GOSH console can be found in connector P1 and the COM port settings are 500000 baud 8n1. On Linux it is recommended to use the program Minicom to see the terminal and on Windows Realterm can be used. For a more detailed description of how to use GOSH please refer the GOSH manual.

10 Software Development

The software for the NanoMind A3200 comes in two packages, the A3200 Board Support Package (BSP) and the A3200 Command & Management SDK.

The Board Support Package includes a patched version of the Atmel Software Framework (ASF) and lowlevel utilities/drivers for the peripherals on the board. ASF also includes FreeRTOS configured for running on the microcontroller.

The A3200 comes with the Board Support Package included. The A3200 Command & Management SDK can be purchased separately.

In the table below the different features are listed for the Standard Software Package and the A3200 Command & Management SDK.

Feature	A3200 Board Support Package	A3200 Command & Management SDK
Utilities (GOSH) and drivers	✓	✓
FreeRTOS	✓	✓
CSP	✓	✓
Parameter System		✓
File Transfer Protocol		✓
Housekeeping (telemetry)		✓
Flight Planner		✓

11 Mechanical Drawing

All dimensions in mm.

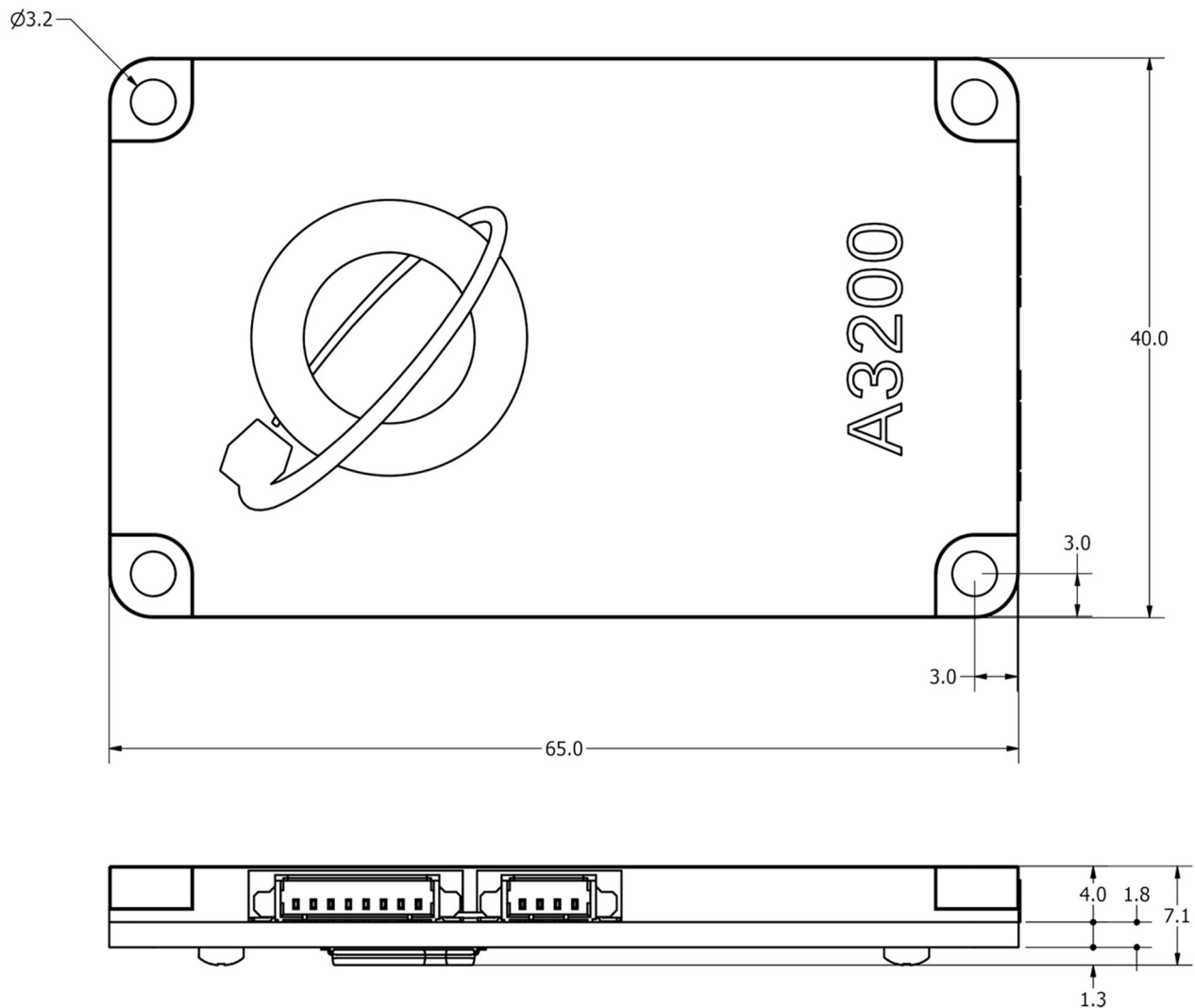

12 Disclaimer

The information in this document is subject to change without notice and should not be construed as a commitment by GomSpace. GomSpace assumes no responsibility for any errors that may appear in this document.

In no event shall GomSpace be liable for incidental or consequential damages arising from use of this document or the software and hardware described in this document.