

NanoPower P60 Dock

Datasheet
Electric Power System for nano satellites

Product name: NanoPower P60 Dock

Document No.: 1013119

Revision: 3.1

Author: JILI

Approved by: PNN

Approval date: 29 Apr 2026

Confidentiality Notice

This document is submitted for a specific purpose as agreed in writing and contains information, which is confidential and proprietary. The recipient agrees by accepting this document, that this material will not be used, transferred, reproduced, modified, copied or disclosed in whole or in part, in any manner or to any third party, except own staff to meet the purpose for which it was submitted without prior written consent.

GomSpace © 2026

1 Table of Contents

2	SYSTEM OVERVIEW	5
2.1	Highlighted Features.....	6
2.2	Module Slots	6
2.4	Block Diagram	7
2.5	CAN Stack Termination Recommendation.....	8
3	CONNECTOR PINOUT.....	9
3.1	Description of the FSI Connectors.....	9
3.2	P60 Dock Top Side.....	9
3.2.1	H1/H2 - Stack Connector.....	10
3.2.2	X1A – FSI.....	11
3.2.3	X1B - FSI	11
3.2.4	X2A – FSI.....	11
3.2.5	X2B – FSI.....	12
3.2.6	P1 - Hard Reset Input	12
3.2.7	P2 - GOSH.....	12
3.2.8	P3 - V_BAT Circuit Breaker.....	12
3.2.9	P4 - BPX Interface Part I	13
3.2.10	P5 - BPX Interface Part II	13
3.2.11	P6 – Release GSSB	13
3.2.12	PJ – JTAG.....	14
3.3	P60 Dock Bottom	15
3.3.1	X3A - FSI	16
3.3.2	X3B - FSI	16
3.3.3	X4A - FSI	16
3.3.4	X4B - FSI	17
3.3.5	P10 - Kill-switch Connector (primary)	17
3.3.6	P11 - Kill-switch Connector (alternative)	17
3.3.7	P12 – BP4 Connector	17
3.3.8	P13 - FPP Connector Part I	18
3.3.9	P14 - FPP Connector Part II	18
3.3.10	P15 - RS-422 TX	18
3.3.11	P16 - RS-422 RX	18
4	KILL SWITCHES.....	19
4.1	P10 – Kill Switches in Parallel	19
4.2	P11 – Kill Switches in Series	20
5	FLIGHT PREPARATION PANEL (FPP)	20
5.1	Remove Before Flight (RBF)	20
5.2	DE-ARM.....	20
5.3	Killswitch_1	21
5.4	Charging the Batteries	21
5.5	Powering up the Spacecraft.....	21
6	HARDWARE RESET	21
7	BATTERY PROTECTION.....	22
7.1	Over Current (OC) Protection	22
7.2	Over Voltage (OV) Protection	22
7.3	Under Voltage (UV) Protection	22

8	CURRENT LIMIT CONSIDERATIONS	23
9	INRUSH CURRENT CONSIDERATIONS	23
10	POWER CONVERTERS	24
11	SAFE MODES AND FALLBACK OPERATION	24
12	BPX INTERFACE	24
13	DATA INTERFACE	25
13.1	CAN-BUS / CFP Protocol	25
13.2	I ² C Communication Protocol.....	25
13.3	KISS Protocol	25
14	DEBUG INTERFACE	25
15	ABSOLUTE MAXIMUM RATINGS	26
16	ELECTRICAL CHARACTERISTICS	26
17	PHYSICAL CHARACTERISTICS	26
18	ENVIRONMENT TESTING	27
19	MECHANICAL DRAWING	28
20	EXAMPLES OF STANDARD CONFIGURATION	29
20.1	Two ACU Modules and Two PDU Modules.....	30
20.2	One ACU Module and One PDU Module	30
20.3	Custom Configuration	30
21	DISCLAIMER	30

2 System Overview

The complete P60 system is designed to be a modular, high capacity power supply for small satellites. It is built around GomSpace modular technology, allowing numerous configurations of modules to be implemented on a P60 Dock, saving significant volume and giving customers a high level of customization.

- Advanced modular high-power EPS for small satellites
- GomSpace modular technology enables EPS customization

Standard configuration includes:

- 1 P60 Dock
- 1 Array Conditioning Unit (ACU) module (6 channels)
- 1 Power Distribution Unit (PDU) module (9 channels)
- 2 free slots for daughterboards
- Easy integration using CAN/I²C enabled CSP and GOSH.

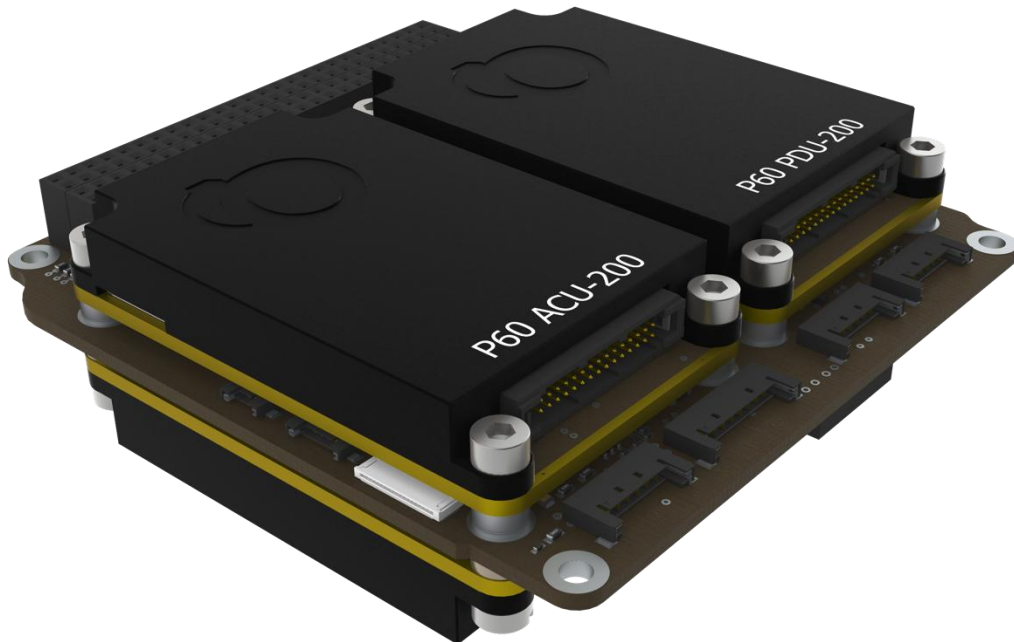

Figure 1 CAD drawing of a motherboard with four shielded daughter boards

2.1 Highlighted Features

P60 Dock

- Up to four modules
 - Input (ACU)
 - Output (PDU)
 - NanoMind A3200
- Regulated 3.3 V and 5 V outputs to PC104 stack
- Kill switch interface
- Synchronized out-of-phase converters for low EMI operation
- Integration with standard GomSpace battery packs, BP4 and BPX
- Recommended battery voltage of 16 V or 32 V
- ISS launch compliant version available
- Supports external reset capability
- Orbit Insertion detection via connection to GomSpace GSSB bus (Coarse Sun Sensors).
- Fits standard PC104
- PCB material: Glass/Polyimide IPC 6012C cl. 3/A
- IPC-A-610 Class 3 assembly

Note that the total power conversion is limited by thermal considerations. Hence installation hardware and operating voltages is indirectly a limiting factor – in general the higher voltage the higher power. That is; the higher the voltage less current needs to flow to attain higher power.

2.2 Module Slots

Both ACU and PDU modules can be mounted on all four slots, a NanoMind A3200 can only be mounted on X3.

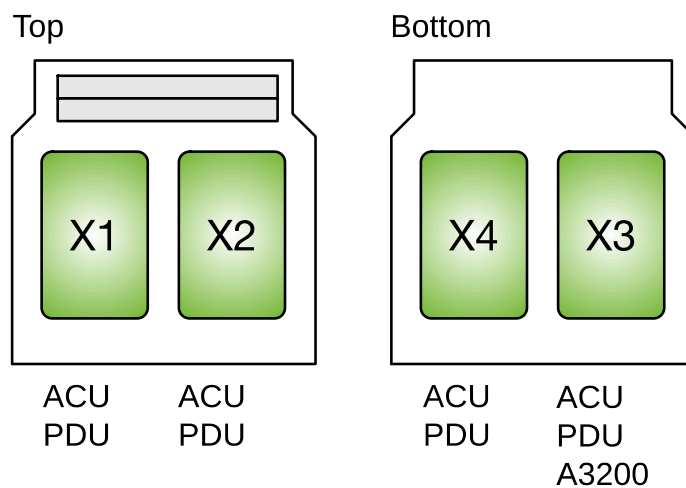

2.4 Block Diagram

The P60 Dock allows up to four daughterboards to be installed. Each daughterboard connects to a protected (unregulated) battery voltage bus through a Power Interface Protection Switch (PIPS). Another PIPS connects to the battery voltage bus to the battery pack, via the optional full current circuit breaker switch (typically rail or deployment switch).

The P60 Dock offers the necessary connections to the stack connector, mainly output power channels and communication interfaces. It contains two buck converters to power the MCU and the daughterboards. These regulated voltages are also available in the stack, though using P60-PDU output power channels is highly recommended.

Two kill switches allow low current enable signals to the system, typically used to inhibit power-on.

The MCU on the P60 Dock controls the system, monitors current, voltage and temperature.

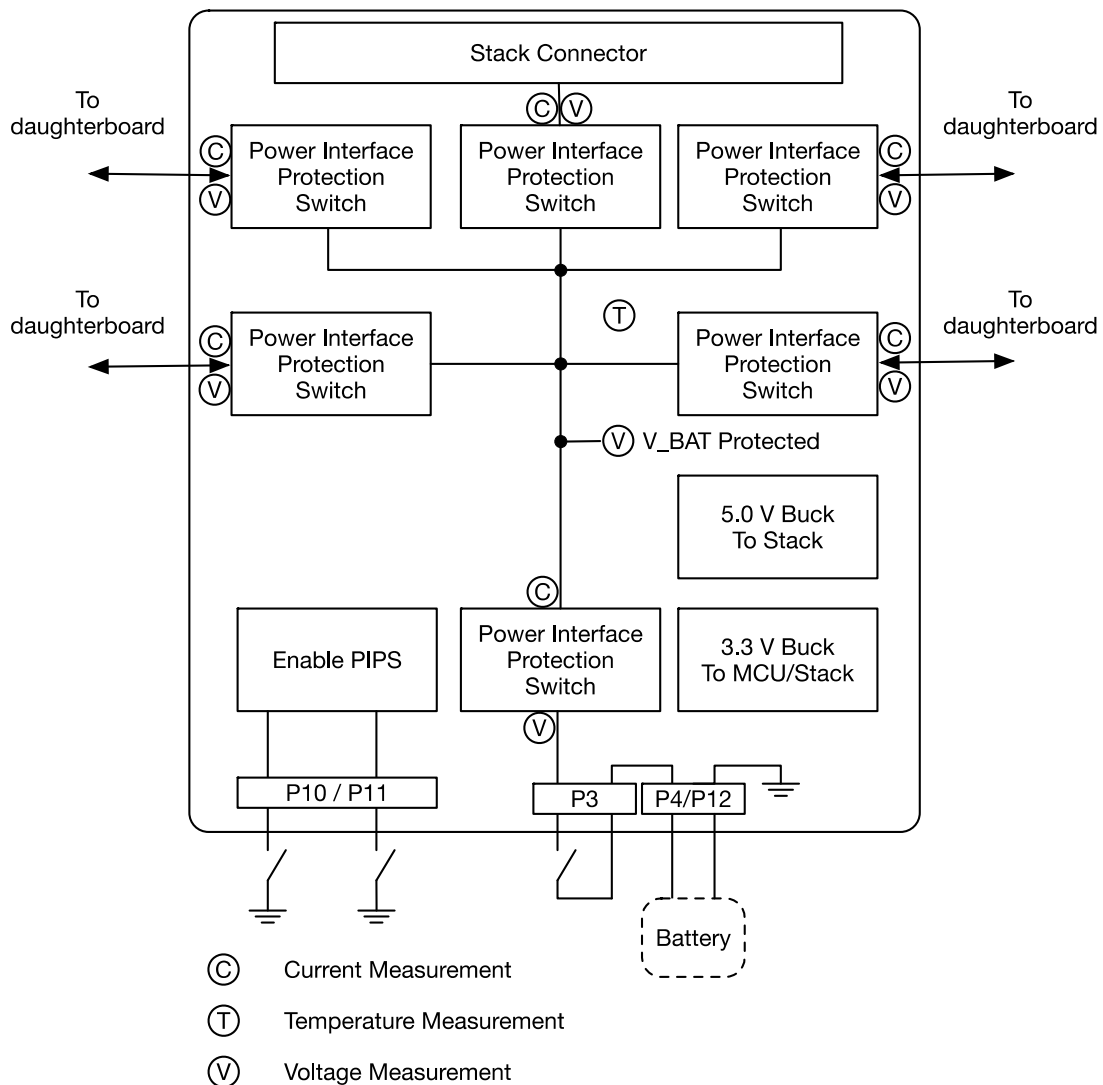

2.5 CAN Stack Termination Recommendation

GomSpace recommends having a $120\ \Omega$ termination resistor in the top and bottom of the CAN bus, to mitigate reflections. The total bus resistance should be $60\ \Omega$. On the NanoPower P60 Dock there is mounted a $120\ \Omega$ termination resistor.

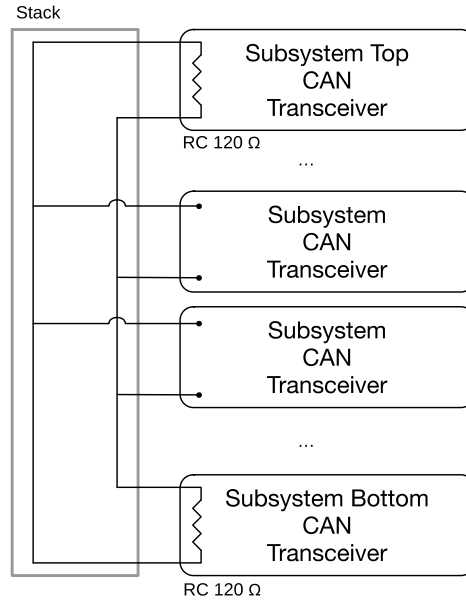

3 Connector Pinout

FSI connector pinouts (X1 to X4) are for reference only. The signals are only used by GomSpace daughterboard (ACU and PDU).

3.1 Description of the FSI Connectors

All FSI connectors are 3 mm tall to allow simple integration with the daughterboards.

Each slot has one or two FSI connectors depending on choice of module. Denoted A and B

The 'A' is used for all modules. On slot X3 a GomSpace NanoMind A3200 can be used. Note that the V_BAT pins are not directly compatible with NanoMind products, hence a correct option sheet configuration is required to avoid V_BAT in the FSI connector A.

The 'B' denoted FSI connector is only used if a PDU module is mounted.

3.2 P60 Dock Top Side

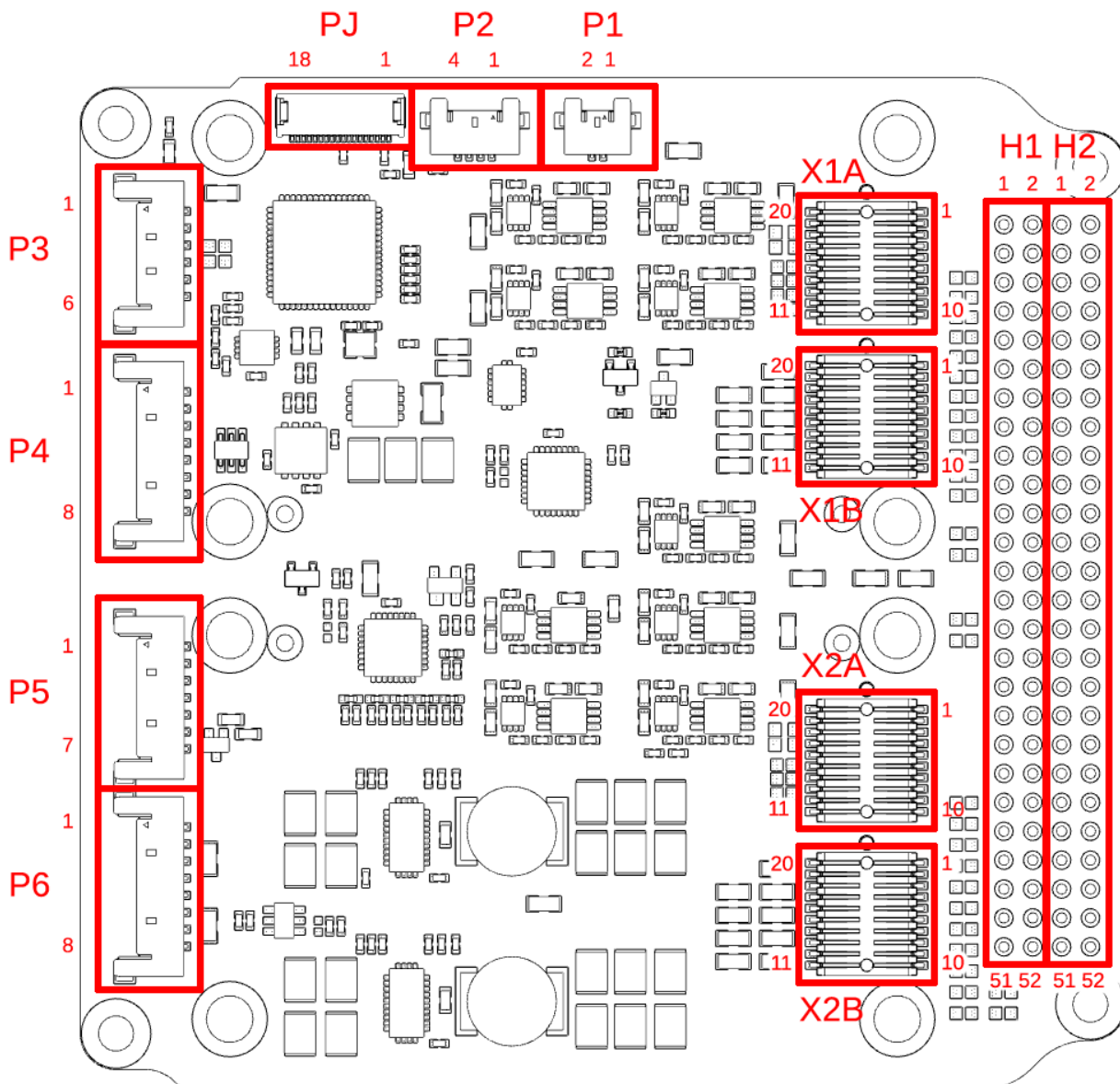

3.2.1 H1/H2 - Stack Connector

Prior to purchase an option sheet is filled out with pin configuration. Option choices are hard soldered into the PCB.

H1

Pin	Description
1	CANL *
2	Reserved for GPS heartbeat
3	CANH *
4	X3 output no. 2 *
5	X3 output no. 0 *
6	X3 output no. 1 *
7	GND *
8	GND *
10	X1 output no. 0 *
12	X1 output no. 3 *
14	X1 output no. 6 *
33	GND *
34	GND *
35	X4 output no. 2 *
36	X4 output no. 5 *
37	X4 output no. 1 *
38	X4 output no. 4 *
39	X4 output no. 0 *
40	X4 output no. 3 *
41	I ² C Bus Data 2k4 pull-up *
43	I ² C Bus Clock 2k4 pull-up *
45	GND *
46	GND *
47	X2 output no. 0 *
48	X2 output no. 1 *
49	X2 output no. 3 *
50	X2 output no. 4 *
51	X2 output no. 6 *
52	X2 output no. 7 *

* Depending on option sheet configuration.

H2

Pin	Description
1	X3 Output no. 5 *
2	X3 Output no. 8 *
3	X3 Output no. 4 *
4	X3 Output no. 7 *
5	X3 Output no. 3 *
6	X3 Output no. 6 *
7	GND *
8	GND *
9	X1 Output no. 1 *
10	X1 Output no. 2 *
11	X1 Output no. 4 *
12	X1 Output no. 5 *
13	X1 Output no. 7 *
14	X1 Output no. 8 *
16	GND *
25	Output 5 V *
26	Output 5 V *
27	Output 3.3 V *
28	Output 3.3 V *
29	GND *
30	GND *
31	GND (Analog) *
32	GND *
35	X4 output no. 8 *
37	X4 output no. 7 *
39	X4 output no. 6 *
45	Output V_BAT *
46	Output V_BAT *
47	X2 Output no. 2 *
48	GND *
49	X2 Output no. 5 *
51	X2 Output no. 8 *
52	GND *

* Depending on option sheet configuration

3.2.2 X1A – FSI

FSI 1.0 mm pitch. Connects the P60 Dock to a mounted GomSpace daughterboard. See chapter 3.1.

Pin	Description	Pin	Description
1	GND	20	GND
2	GND	19	GND
3	VCC	18	5 V
4	VCC	17	Boost converter enable
5	SCL	16	V_BAT
6	SCA	15	V_BAT
7	CANH	14	V_BAT
8	CANL	13	V_BAT
9	V_BAT	12	Not connected
10	V_BAT	11	Not connected

3.2.3 X1B - FSI

FSI 1.0 mm pitch. Connects the P60 Dock to a mounted GomSpace Nanopower P60-PDU daughterboard. See chapter 3.1.

Pin	Description	Pin	Description
1	Output 0	20	Output 0
2	Output 1	19	Output 1
3	Output 2	18	Output 2
4	Output 3	17	Output 3
5	Output 4	16	Output 4
6	Output 5	15	Output 5
7	Output 6	14	Output 6
8	Output 7	13	Output 7
9	Output 8	12	Output 8
10	GND	11	GND

3.2.4 X2A – FSI

FSI 1.0 mm pitch. Connects the P60 Dock to a mounted GomSpace daughterboard. See chapter 3.1.

Pin	Description	Pin	Description
1	GND	20	GND
2	GND	19	GND
3	VCC	18	5 V
4	VCC	17	Boost converter enable
5	SCL	16	V_BAT
6	SCA	15	V_BAT
7	CANH	14	V_BAT
8	CANL	13	V_BAT
9	V_BAT	12	Not connected
10	V_BAT	11	Not connected

3.2.5 X2B – FSI

FSI 1.0 mm pitch. Connects the P60 Dock to a mounted GomSpace NanoPower P60 PDU daughterboard. See chapter 3.1.

Pin	Description	Pin	Description
1	Output 0	20	Output 0
2	Output 1	19	Output 1
3	Output 2	18	Output 2
4	Output 3	17	Output 3
5	Output 4	16	Output 4
6	Output 5	15	Output 5
7	Output 6	14	Output 6
8	Output 7	13	Output 7
9	Output 8	12	Output 8
10	GND	11	GND

3.2.6 P1 - Hard Reset Input

Molex Pico-lock 1.0 mm pitch. 503763-0291. Internally pulled up. Open drain input.

Pin	Description
1	GND
2	Hard reset input (active low)

3.2.7 P2 - GOSH

Molex Pico-lock 1.0 mm pitch. 503763-0491. TX is e.g. from MB to PC. RX is from PC to MB.

Pin	Description
1	GND
2	UART TX
3	UART RX
4	Not connected

3.2.8 P3 - V_BAT Circuit Breaker

Molex Pico-lock 1.5 mm pitch. 504050-0691.

Allows high-current rail switches to comply with NanoRacks launches from the International Space Station (ISS). Requires NC switches with high current carrying capacity.

Pin	Description
1	V_BAT_DIRECT
2	V_BAT_DIRECT
3	V_BAT_DIRECT
4	V_BAT
5	V_BAT
6	V_BAT

3.2.9 P4 - BPX Interface Part I

Molex Pico-lock 1.5 mm pitch. 504050-0891

Connect to GomSpace NanoPower BPX. View chapter 12.

Pin	Description
1	V_BAT_DIRECT
2	V_BAT_DIRECT
3	V_BAT_DIRECT
4	V_BAT_DIRECT
5	GND_DIRECT
6	GND_DIRECT
7	GND_DIRECT
8	GND_DIRECT

3.2.10 P5 - BPX Interface Part II

Molex Pico-lock 1.5 mm pitch. 504050-0791

Connect to GomSpace NanoPower BPX. View chapter 12.

Pin	Description
1	GND
2	SCL
3	SDA
4	EN_BPX (active high)
5	CANH
6	CANL
7	EN_BPX (active low)

3.2.11 P6 – Release GSSB

Molex Pico-lock 1.5 mm pitch. 504050-0891.

P6 is used for GomSpace Sensor/Release Bus. The I²C interface can be used to communicate with sun sensors, pin 3 and 4 for supplying the sun sensors and pins 5 through 8 is for an antenna release mechanism.

Pin	Description
1	I ² C Data
2	I ² C CLK
3	3.3 V
4	GND
5	5 V
6	5 V
7	GND
8	GND

3.2.12 PJ – JTAG

FPC-51281-1894

Programming and test connector. Only for ground testing, and should not be used in flight. Only use on GomSpace’s instruction.

The UART is the same as in P2. Only connect one of P2 or PJ at any given time.

Pin out table supplied for reference only.

Pin	Description
1	GND
2	VCC
3	RESET_N
4	JTAG_TDI
5	JTAG_TMS
6	JTAG_TCK
7	JTAG_TDO
8	GND
9	VCC
10	UART_RX
11	UART_TX
12	Not connected
13	Not connected
14	Not connected
15	Not connected
16	Not connected
17	Not connected
18	GND

3.3 P60 Dock Bottom

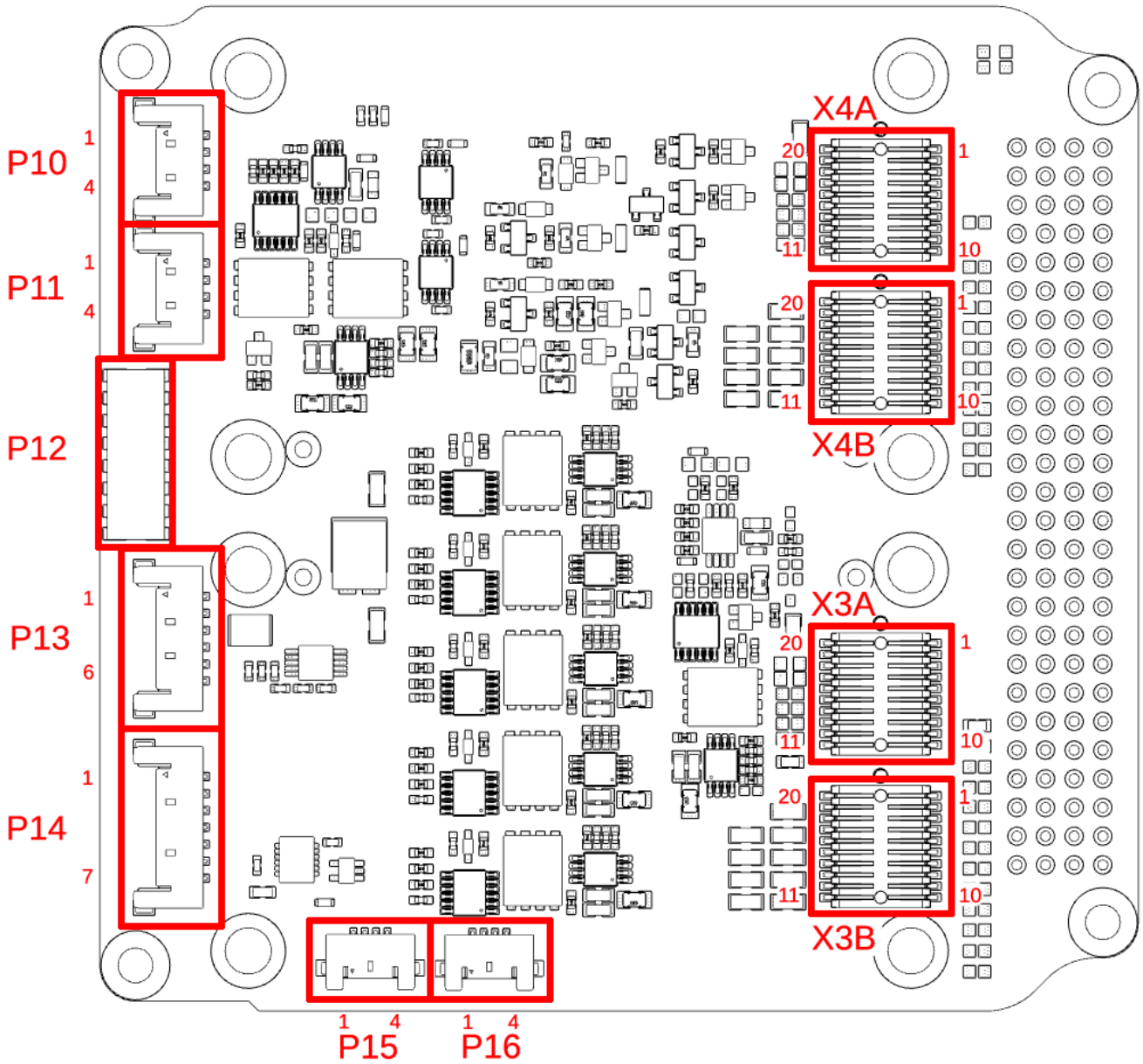

3.3.1 X3A - FSI

FSI 1.0 mm pitch. Connects the P60 Dock to a mounted GomSpace daughterboard. See chapter 3.1.

Pin	Description	Pin	Description
1	GND	20	GND
2	GND	19	GND
3	VCC	18	5 V
4	VCC	17	Boost converter enable
5	SCL	16	V_BAT
6	SCA	15	V_BAT
7	CANH	14	V_BAT
8	CANL	13	V_BAT
9	V_BAT	12	Not connected
10	V_BAT	11	Not connected

3.3.2 X3B - FSI

FSI 1.0 mm pitch. Connects the P60 Dock to a mounted GomSpace NanoPower P60 PDU daughterboard. See chapter 3.1.

Pin	Description	Pin	Description
1	Output 0	20	Output 0
2	Output 1	19	Output 1
3	Output 2	18	Output 2
4	Output 3	17	Output 3
5	Output 4	16	Output 4
6	Output 5	15	Output 5
7	Output 6	14	Output 6
8	Output 7	13	Output 7
9	Output 8	12	Output 8
10	GND	11	GND

3.3.3 X4A - FSI

FSI 1.0 mm pitch. Connects the P60 Dock to a mounted GomSpace daughterboard. See chapter 3.1.

Pin	Description	Pin	Description
1	GND	20	GND
2	GND	19	GND
3	VCC	18	5 V
4	VCC	17	Boost converter enable
5	SCL	16	V_BAT
6	SCA	15	V_BAT
7	CANH	14	V_BAT
8	CANL	13	V_BAT
9	V_BAT	12	Not connected
10	V_BAT	11	Not connected

3.3.4 X4B - FSI

FSI 1.0 mm pitch. Connects the P60 Dock to a mounted GomSpace NanoPower P60-PDU daughterboard. See chapter 3.1.

Pin	Description	Pin	Description
1	Output 0	20	Output 0
2	Output 1	19	Output 1
3	Output 2	18	Output 2
4	Output 3	17	Output 3
5	Output 4	16	Output 4
6	Output 5	15	Output 5
7	Output 6	14	Output 6
8	Output 7	13	Output 7
9	Output 8	12	Output 8
10	GND	11	GND

3.3.5 P10 - Kill-switch Connector (primary)

Molex Pico-lock 1.5 mm pitch. 504050-0491

See chapter 4 for more detail.

Pin	Description
1	GND
2	Kill-switch ch_2
3	GND
4	Kill-switch ch_1

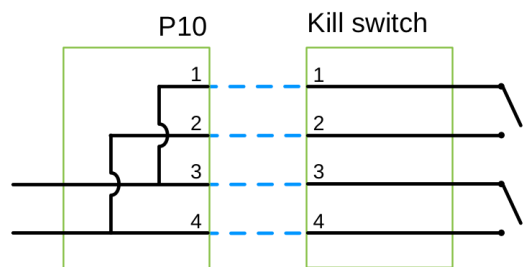

3.3.6 P11 - Kill-switch Connector (alternative)

Molex Pico-lock 1.5 mm pitch. 504050-0491

See chapter 4 for more detail.

Pin	Description
1	GND
2	Kill-switch ch_Intermediate
3	Kill-switch ch_Intermediate
4	Kill-switch ch_1

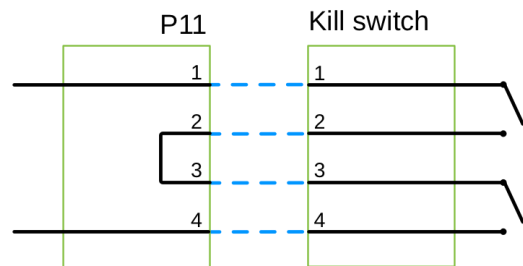

3.3.7 P12 – BP4 Connector

Samtec SQW-108-01-L-D

Connector to a GomSpace NanoPower BP4. See the BP4 datasheet.

3.3.8 P13 - FPP Connector Part I

Molex Pico-lock 1.5 mm pitch. 504050-0691

P13 and P14 are used together for Flight Preparation Panel (FPP). See chapter 5 for more detail.

Pin	Description
1	GND
2	GND
3	V_BAT_Sense
4	V_BAT_Charge
5	V_BAT_DIRECT
6	V_BAT

3.3.9 P14 - FPP Connector Part II

Molex Pico-lock 1.5 mm pitch. 504050-0791

P13 and P14 are used together for Flight Preparation Panel (FPP). See chapter 5 for more detail.

Pin	Description
1	CAN_L
2	CAN_H
3	GND
4	Kill-switch_1
5	GND
6	RBF
7	DE-ARM

3.3.10 P15 - RS-422 TX

Molex Pico-lock 1.0 mm pitch. 503763-0491

Use P15 and P16 together for RS-422 connection to the MB.

Pin	Description
1	GND
2	Not connected
3	TX_N
4	TX_P

3.3.11 P16 - RS-422 RX

Molex Pico-lock 1.0 mm pitch. 503763-0491

See P15.

Pin	Description
1	GND
2	Not connected
3	RX_N
4	RX_P

4 Kill switches

At the top or bottom of a nano-satellite are sets of switches, which are pressed down while the satellite is placed in its orbital deployer. These switches are referred to as kill switches. While the buttons are pressed the satellite cannot power up. As soon as the satellite is released, the satellite can power up.

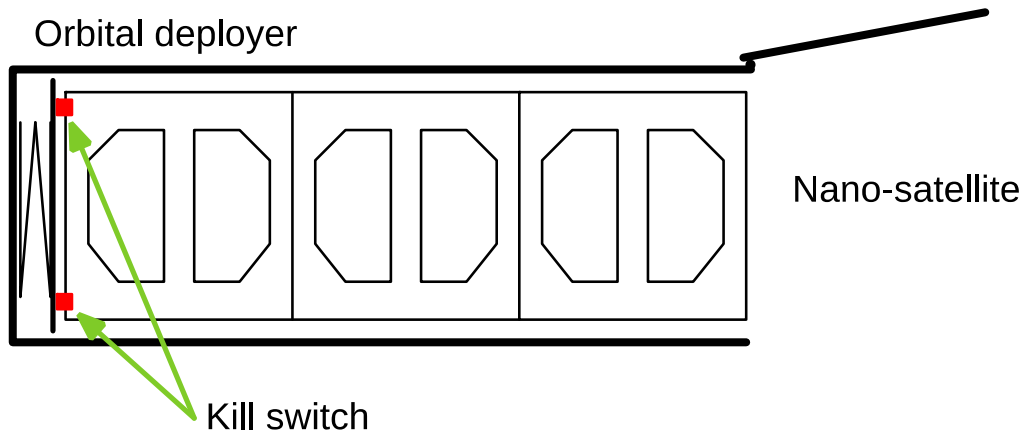

Figure 2 An example of a 3U nano-satellite in an orbital deployer. Kill switches indicated with red

While the buttons are pressed the kill switch circuits are open and no current can run through; satellite is powered down. And vice-versa.

Depending on how the switches are connected to the hardware they can be set in either a parallel (P10) or serial (P11) setup e.g. how many buttons to release before power up.

4.1 P10 – Kill Switches in Parallel

P10 connects kill-switches in parallel (used by default).

The parallel connection of the two switches is handled on the P60 Dock PCB. By connecting the two kill switches in parallel; only one of the switches has to be release for the satellite to power up. This works as redundancy system therefore the P10 connector is highly recommended for connecting the kill switches.

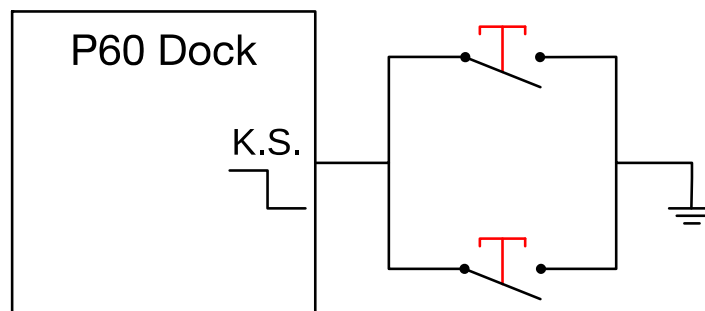

Figure 3 Principle electrical kill switches parallel electric circuit

4.2 P11 – Kill Switches in Series

P11 connects kill switches in series (optional).

The series connection of the two kill switches is handled on the P60 Dock PCB. By connecting the two kill switches in series both switches has to be released before the satellite can power up.

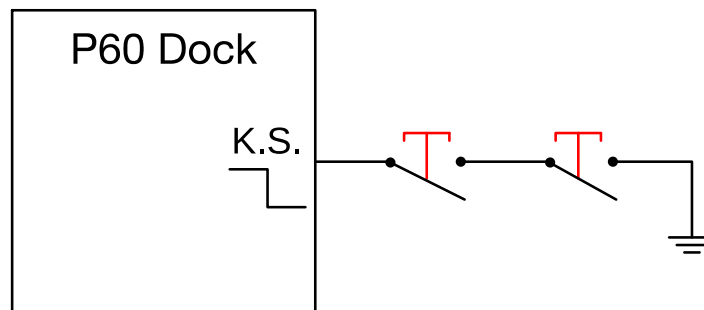

Figure 4 Principle electrical kill switch serial electric circuit

5 Flight Preparation Panel (FPP)

A Flight Preparation Panel (FPP) is a panel placed on the spacecraft such that it is accessible from outside and preferably accessible when the spacecraft is placed in the orbital deployer. The reason for having an FPP is to be able to charge the batteries and communicate with the subsystems of the spacecraft and also in to be able to insert a Remove Before Flight (RBF) jumper, ensuring that the spacecraft is powered down when e.g. transporting or handling the spacecraft. A kill switch override is also accessible on the FPP.

The use of the FPP listed in (see chapter 3.3.8 and 3.3.9) are described in the chapters below. A set of examples are given and explained as to give the user an idea of a use.

5.1 Remove Before Flight (RBF)

The RBF pin is an active low shutdown input located on pin 6 of P14. As long as the RBF pin is pulled to ground the spacecraft cannot power up, however it is possible to charge the batteries with it inserted.

The RBF pin is a high-impedance input and should not be left exposed or unterminated external to the satellite. To ensure robust and reliable operation, the following practices are recommended for satellite missions:

- Cover the FPP panel with a metal plate, for example anodized aluminum with a minimum thickness of 1 mm. The cover plate should be electrically bonded to the satellite structure.
- Install a 2 M Ω pull-up resistor between VBAT and the RBF pin on the FPP panel. The resistor should be placed as close as possible to the RBF pin.
- Insert a 220 Ω series resistor in the RBF signal harness between the FPP panel and the P60 FPP connector. The series resistor should be located close to the P60 FPP connector.

5.2 DE-ARM

Pin 7 in P14 is a De-Arm pin. The De-Arm is an active low input. When active; the antenna release system is deactivated. This prevents unintentional antenna releases and it is recommended that this input is connected to the FPP such that a jumper can be inserted shorting this input to ground.

5.3 Killswitch_1

Pin 4 in P14 is an active low input. The killswitch_1 input is able to override the kill switch signals from those mounted on the outside of the spacecraft. This allows powering up the spacecraft even when the kill switches are pressed. It overrides only the kill switches and not the RBF input.

5.4 Charging the Batteries

The battery charging interface is located in connector P13 where the pins one through four is used for charging. Pin one and two is ground connection to the battery; pin three is a battery voltage sense output which should be used with the battery charger and pin four is the charge input for the battery. Pins five and six are used if a high current VBAT circuit breaker functionality is used with the P60 Dock. If the high current VBAT circuit breaker is used then these pins need to be connected to the FPP panel. On the GomSpace NanoPower BPX and BP4 battery packs there is a connector for a high current GND circuit breaker - if this is used then you also need to connect this to the FPP.

View Electrical Characteristics chapter 16 for maximum charge current.

With these connections in the FPP then a procedure for charging the batteries in a spacecraft is:

- 1) Connect the battery charger to GND, V_BAT_Sense and V_BAT_Charge.
- 2) Connect GND to GND_DIRECT.
- 3) Connect V_BAT to V_BAT_DIRECT
- 4) Start the charger

Steps two and three only need to be performed if the high current circuit breakers are used.

To charge the batteries while the spacecraft is powered down, use P13 Pin 1-4 only. Do NOT connect to V_BAT_DIRECT. Always use a charger with UV, OV and OC protection and separate sense connection.

5.5 Powering up the Spacecraft

When powering up the spacecraft connections from both P13 and P14 are needed. The spacecraft could for instance be located in the orbital deployer ready for the launch vehicle or be in the lab.

A procedure for this is described below.

- 1) Connect GND to GND_DIRECT.
- 2) Connect V_BAT to V_BAT_DIRECT.
- 3) Connect Kill-switch_1 to GND.
- 4) Remove the RBF jumper.

6 Hardware Reset

The Hardware Reset input located in connector P1 is an input, which allows for a subsystem being able to perform a power cycle of the spacecraft. This could for instance be from a reliable radio where a user or operator could send a firecode and thereby triggering a power cycle of the spacecraft.

The hardware reset input is an open drain input that needs to be exposed to a falling edge and a rising edge in order to be triggered. That is, the hardware reset needs to be exposed to an active low pulse with a length of 10 to 15 ms. This design ensures that noise on the input cannot trigger a power cycle inadvertently.

7 Battery Protection

The battery protection built into the P60 power supply consists of three parts; over voltage protection, under voltage protection and over current protection. Each of the three serves to protect the batteries from strain that might damage or shorten the lifetime of the batteries. In the following sections, each of the three will be described.

7.1 Over Current (OC) Protection

To ensure that the spacecraft subsystems are not allowed to draw more current from the batteries than the batteries are rated to, an OC protection function is built into the P60.

The OC protection is located in the PIPS directly connected to the batteries. The OC protection is triggered by the total current draw from the five PIPS outputs in the P60 Dock; the four FSI connectors and the VBAT located in the stack connector. The five individual PIPS are Latch-Up protected.

7.2 Over Voltage (OV) Protection

The OV protection feature of the P60 protects the batteries from an over charge condition. The OV is located in the P60 Dock. If the voltage across the batteries reaches the maximum safe, then the OV protection stops the charging. When the batteries are discharged to the OV threshold minus a hysteresis band then the charging is allowed again.

The OV protection thresholds levels for the two voltage versions of the P60, are listed below:

- 16 V: 16.8 V
- 32 V: 33.6 V

7.3 Under Voltage (UV) Protection

The UV protection feature protects the batteries from an under charge condition. The UV is located in the P60 Dock. When the discharge level of the batteries reaches the minimum safe level the UV protection turn of the power supply until the batteries are charged to a safe level plus a hysteresis band.

The UV protection threshold levels for the two voltage versions of the P60, are listed below:

- 16 V: 12 V
- 32 V: 24 V

8 Current Limit Considerations

The block diagram below illustrates the different Vbat current limits and current ratings, across the P60 Dock and P60 PDU-200. On the Dock the overcurrent limit is shown along a Vbat switch supplying the PDU-200 with battery voltage. On the PDU-200 a single buck converter is shown next to a few load switches. The different current limits and ratings can be found in their own datasheets and the block diagram illustrates how they affect each other and the overall system design.

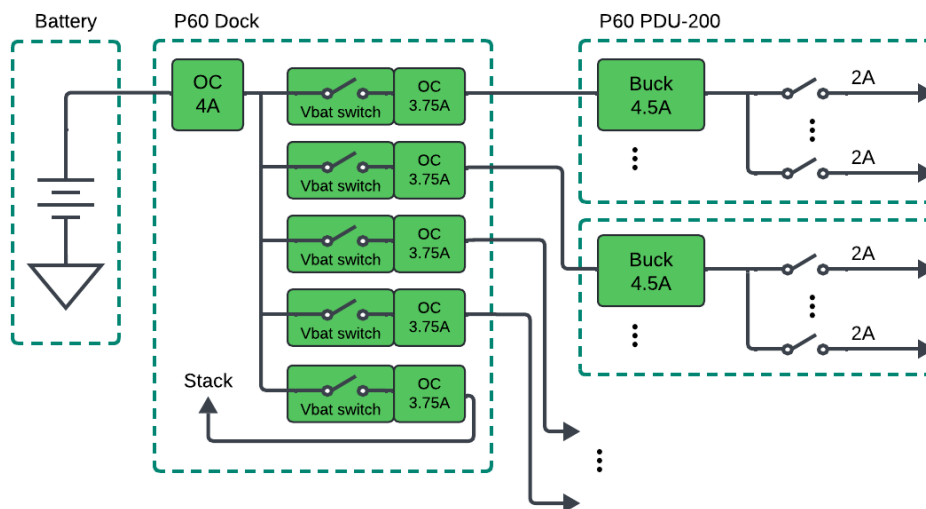

At the PDU-200, there are 9 output channels, each rated to 2 A, where each of the three Buck converters is rated to 4.5 A. This means that if only two channels are connected to one converter the full 2 A can be realized from each channel at the same time; however, if three or more channels are connected to the same regulator it is left to the system designer to make sure that the buck converter is not loaded with more than 4.5 A.

The Dock allows for up to four PDU-200s. Each PDU-200 is protected by an overcurrent limit of 3.75 A. However, the 4A battery overcurrent limit sets the maximum intake of current from the battery hence the power able to be delivered to the PDU-200's in total. In general – a higher battery voltage allows for a higher power. If more than one PDU-200 is utilized on a single Dock, then it is likewise left to the system designer to ensure that no more than 4 A is drawn at the same time from the battery.

9 Inrush Current Considerations

When driving high capacitive load from one of the PDU-200's high-voltage channels, the power on inrush current might exceed the overcurrent protection limit of 3.75A and causes interruption of the PDU power supply or reset of the Dock. For P60 Dock with serial number 300 and forward, this situation can be avoided by implementing a specific sequence to turn on the high-voltage channel in question. The power on sequence is described as follows:

1. Turn on the VCC supply to the PDU.
2. Configure the PDU channel output so that the high-voltage channel, which is driving the capacitive load, remains turned on under Battery mode SAFE and NORMAL. This can be done by setting the appropriate configuration parameters `init_out_safe[]` and `init_out_norm[]` to 1. The corresponding `init_on_dly[]` parameter must be 0, which means there is no delay. Refer to the PDU-200 Manual for more details.
3. Turn on the PDU high-voltage channel.
4. Turn on the V_BAT supply to the PDU. The V_BAT voltage ramps up at a slew rate of 3.75V/ms typically. The PDU high-voltage channel output will follow the V_BAT ramp rate.
5. When the PDU high-voltage channel output reaches the desired voltage, the configuration parameters `init_out_safe[]` and `init_out_norm[]` may be resumed to 0, depending on the system application requirements.

10 Power Converters

There are two power converters located on the P60 Dock, a 3.3 V and a 5 V converter. These two converters are used to supply the daughterboards, internal logic, 5 V and 3.3 V in the stack and for antenna release.

11 Safe Modes and Fallback Operation

The P60 design is limited in size and complexity, to allow a fair number of high power channels in a small spacecraft. Hence there is no room for redundancy. The GomSpace recommended way of achieving redundancy is by using two power systems. However, the P60 includes a number of hardware fallback modes that allow basic operation in case parts of the circuit is defect. The main strategies are:

- Hardware fallback on ACU200 module - OV
- Error detection on the P60 Dock
- Multiple output modules

The hardware fallback on the ACU serves two functions. One is to power on the spacecraft from low battery voltage and the other is to allow input power conversion even in case of MCU failure. The hardware fallback uses a fixed power point on the converter of 4.5 V (maximum power point tracking not enabled). It should be mentioned that the 6 input converters on an ACU is paired two and two. All 6 inputs are individual converters with individual power point tracking, but they share control components in pairs of two. The pairs are PV0 and PV1, PV2 and PV3, PV4 and PV5. This means that the available strings should be divided equally, e.g. if only two inputs are used connect to PV0 and PV5. If three inputs are used connect to PV0, PV3 and PV4.

Error detection on the P60 Dock allows fault isolation on a module level. This means that a failed ACU or output module can be disconnected from the system.

When using multiple PDU modules and communication systems it is recommended to connect one radio to the one output module and the other radio to another output module.

12 BPX Interface

Below is a table to help with a split harness between the P60 Dock (P4 and P5) and a BPX (PBAT2)

	BPX	P60	
	PBAT2	P4	P5
GND	1	5	
GND	2	6	
GND	3	7	
GND	4	8	
VBAT_RAW Battery Voltage	5	1	
VBAT_RAW Battery Voltage	6	2	
VBAT_RAW Battery Voltage	7	3	
VBAT_RAW Battery Voltage	8	4	
I2C SCK	9		2
Enable BPX	10		4
I2C Data	11		3
GND	12		1
Not connected	13		
Kill switch	14		7

13 Data Interface

The P60 uses the CubeSat Space Protocol (CSP) to transfer data to and from CSP nodes on-board the main system bus. CSP is a routed network protocol that can be used to transmit data packets between individual subsystems on the satellite bus and between the satellite and ground station. For more information about CSP please read the documentation on libcsp.org and on Wikipedia: http://en.wikipedia.org/wiki/Cubesat_Space_Protocol

The CSP network layer protocol spans multiple data-link layer protocols, such as CAN-bus, I²C and KISS.

13.1 CAN-BUS / CFP Protocol

The standard method to communicate with the P60 is the CAN-bus. The CAN interface on the P60 uses the CSP CAN Fragmentation Protocol (CFP). CFP is a simple method to make CSP packets of up to 256 bytes, span multiple CAN messages of up to 8 bytes each. The easiest way to implement CSP/CFP over CAN is to download the CSP source code from <http://libcsp.org> and compile the CFP code directly into your own embedded system.

The CAN-bus is connected to each individual module.

13.2 I²C Communication Protocol

It is possible to communicate with the P60 modules over multi-master I²C. Please note that since the CSP router sends out an I²C message automatically when data is ready for a subsystem residing on the I²C bus. The bus needs to be operated in I²C multi-master mode.

The P60 uses the same I²C address as the CSP network address per default. This means that if a message is sent from the radio link, to a network node called 1, the P60 will route this message to the I²C interface with the I²C destination address 1.

The I²C bus is connected to each individual module in the P60 system.

13.3 KISS Protocol

The KISS protocol uses special framing characters to identify a data-packet on a serial connection. It is designed to be easy to implement in simple embedded devices, which are capable of asynchronous serial communications. [http://en.wikipedia.org/wiki/KISS_\(TNC\)](http://en.wikipedia.org/wiki/KISS_(TNC))

The KISS protocol is available on the P60 Dock RS-422 and UART connector (TTL level). This is not a bus but a point to point connection. Hence the CSP routing service is used to allow communication with daughterboards in the P60 system.

14 Debug Interface

The debug interface is a USART that uses the GomSpace Shell (GOSH) to present a console-like interface to the user. GOSH is a general feature present on all GomSpace products.

The console can be used during checkout of the P60 to send commands and set parameters. During integration into the satellite, the debug interface can be used to monitor incoming and outgoing traffic through the P60.

15 Absolute Maximum Ratings

Stresses above those listed under Absolute Maximum Ratings may cause permanent damage to the P60. Exposure to absolute maximum rating conditions for extended periods may affect the reliability.

Symbol	Description	Min.	Max.	Unit
T _{amb}	Operating Temperature	-35	+85	°C
V _{io}	Voltage on I ² C/USART pins	-0.1	3.4	V

16 Electrical Characteristics

Parameter	Condition	Min.	Typ.	Max.	Unit
Battery - Voltage	Battery connection 16 volt 32 volt	12.0	14.8	16.80	V
		24.0	29.6	33.6	V
- Current, charge	Combined charge current to ACU			4	A
- Current, discharge	(Depends on battery configuration) Overcurrent protection threshold		4		A
FPP_charge	View chapter 5.4			1	A
+ 5 V Stack connector - Voltage - Current, cont.	5 V regulated output	4.89	5.20	5.35	V
	Total current H2-25 and H2-26	0		1.00	A
+ 3.3 V Stack connector - Voltage - Current, cont.	3.3 V regulated output From -35 °C to +85 °C	3.20	3.29	3.39	V
	Total current H2-27 and H2-29	0.00		0.50	A
V_BAT Stack connector - Voltage - Current, cont.	Raw battery voltage (Depends on battery configuration)		1.0		V
	H2-45 and H2-46				A
FSI – VCC	Typical value per daughter board		0.2	0.5	A

17 Physical Characteristics

Description	Value	Unit
Mass	80	g
Size	Standard PC104 fit 90 x 96	mm

18 Environment Testing

To simulate the harsh conditions in launch and space, the NanoDock P60 has been exposed to several environment tests. For detailed information about the tests please contact GomSpace.

19 Mechanical Drawing

All dimensions in mm. The height of the stack connector depends on the choice in the option sheet. Here shown with four and two modules installed.

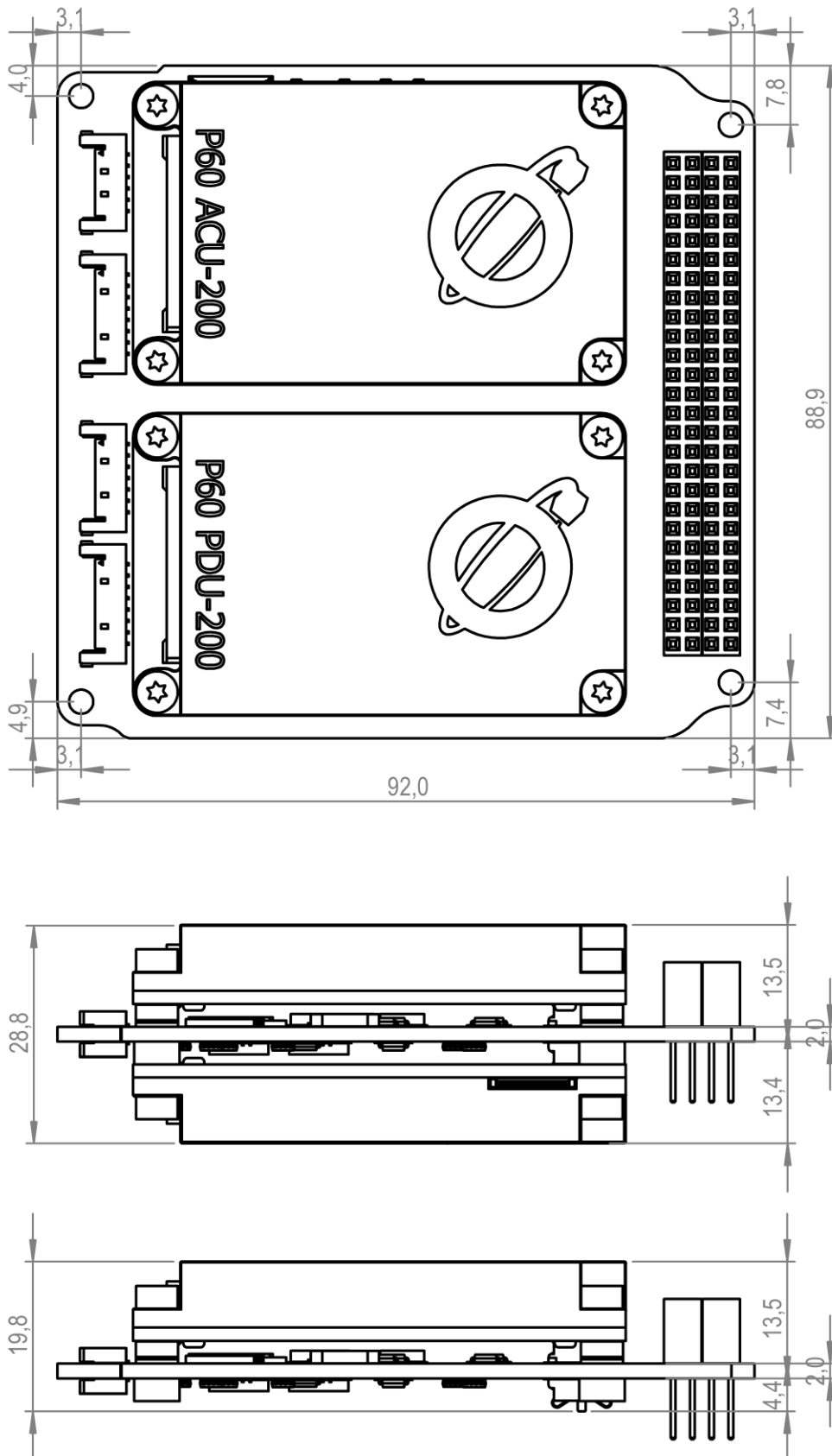

20 Examples of Standard Configuration

The P60 Dock can fit up to four GomSpace NanoDock compatible daughterboards. Below are two CAD drawn examples of typical setups.

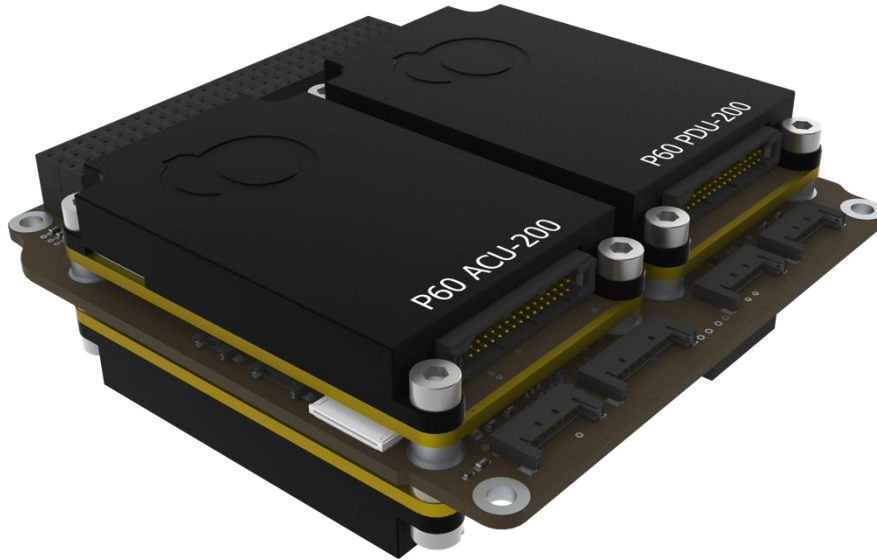

Figure 5 Dock with one ACU and three PDU modules

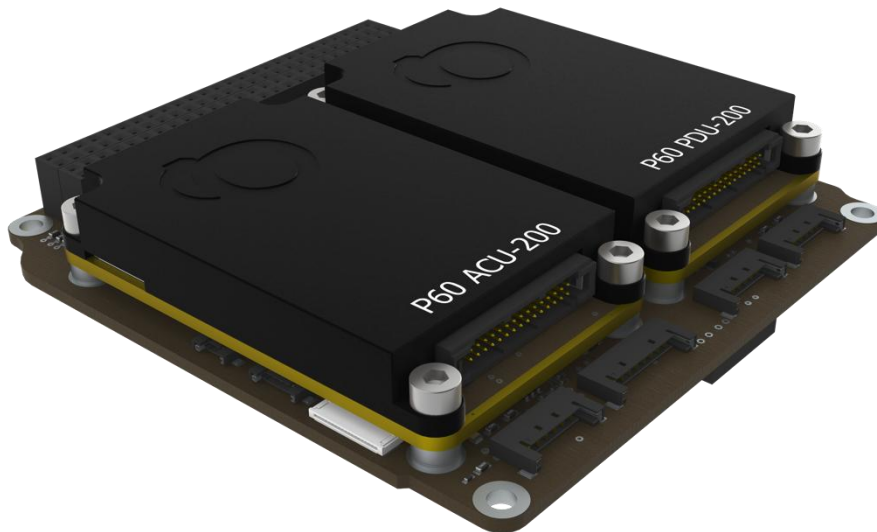

Figure 6 Dock with ACU and one PDU module

20.1 Two ACU Modules and Two PDU Modules

In the default mode, this configuration includes ACU modules on the X1 and X3 location, and PDU modules on the X2 and X4 position.

20.2 One ACU Module and One PDU Module

An ACU module is placed in the X1 location and Output module in the X2 location (both on the top side).

20.3 Custom Configuration

In the custom configuration option the spacecraft designer can mix and match modules as needed. This allows a high level of flexibility. In cases where less than four modules are used from the NanoPower product line, a NanoMind A3200 can be fitted.

Each configuration can be used with a GomSpace battery pack, either the BPX or the BP4 in 16 or 32 V configurations. However, it must be considered that the PV inputs are boost converters, and therefore the battery voltage must be higher than the highest PV input voltage.

21 Disclaimer

The information in this document is subject to change without notice and should not be construed as a commitment by GomSpace. GomSpace assumes no responsibility for any errors that may appear in this document.

In no event shall GomSpace be liable for incidental or consequential damages arising from use of this document or the software and hardware described in this document.