



NanoUtil MSP-FPP

Datasheet

Small Flight Preparation Panel for nano-satellites with USB hub

Product name: NanoUtil MSP-FPP

Document No.: 1014569

Revision: 1.7

Author: KLK

Approved by: FJH

Approval date: 29 October 2018

Confidentiality Notice

This document is submitted for a specific purpose as agreed in writing and contains information, which is confidential and proprietary. The recipient agrees by accepting this document, that this material will not be used, transferred, reproduced, modified, copied or disclosed in whole or in part, in any manner or to any third party, except own staff to meet the purpose for which it was submitted without prior written consent.

GomSpace © 2025

1 Table of Contents

2	OVERVIEW	4
2.1	Highlighted Features.....	4
2.2	Utility Plate and PCB Mounting.....	5
2.3	Block Diagram	5
3	HARDWARE LAYOUT	6
3.1	Connector Location Top	6
3.1.1	J1 – Standard Mini USB	6
3.1.2	J8 – Flight Preparation Panel Pins	7
3.1.3	J9 – Battery Voltage	8
3.1.4	J10 - Battery Voltage Sensing Pins	8
3.1.5	J11 - CAN Interface	8
3.2	Connector Location Bottom	9
3.2.1	J2 – Connect to NanoPower P60 Dock (connector P13)	9
3.2.2	J3 – Connect to Sub Modules with USB Interface.....	9
3.2.3	J4 – Connect to Sub Modules with USB Interface.....	10
3.2.4	J5 – Connect to Sub Modules with USB Interface.....	10
3.2.5	J6 – Connect to NanoPower BPX (connector PGND1).....	10
3.2.6	J7 - Connect to NanoPower P60 Dock (connector P14)	10
4	ABSOLUTE MAXIMUM RATINGS	11
5	PHYSICAL CHARACTERISTICS	11
6	DISCLAIMER	11
7	MECHANICAL DRAWING	12
8	USING MSP-FPP WITH OTHER GOMSPACE PRODUCTS	13

2 Overview

The NanoUtil MSP-FPP is a small Flight Preparation Panel for 6U nano-satellites. It is designed to be used alongside the GomSpace NanoPower MSP. The connectors on the top of the PCB can be reached from the outside of the satellite, and those on the bottom are used to connect to other subsystems inside the satellite.

The MSP-FPP PCB is mounted on a utility plate that can be mounted on a frame. The plate can also hold a small GPS antenna and a Fine Sun Sensor. When mounted on a side of the satellite, the plate and pins do stick up somewhat. Check the mechanical drawing for measurements.

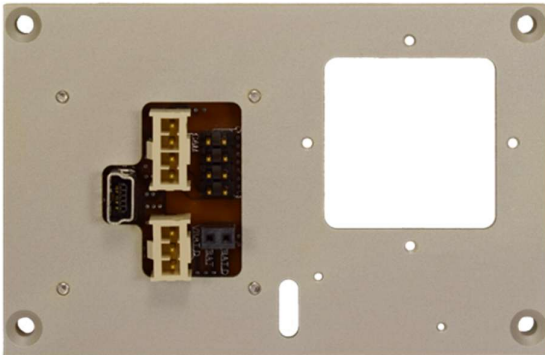

Figure 1 MSP-FPP top

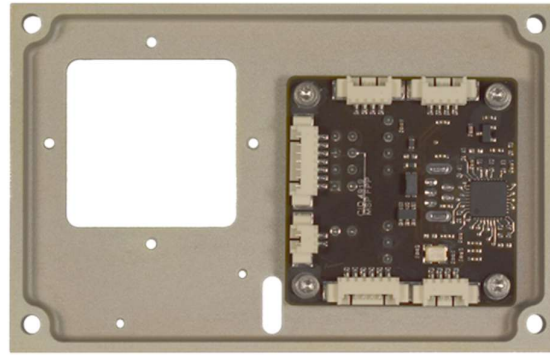

Figure 2 MSP-FPP bottom



Figure 3 MSP-FPP (without GPS antenna and FSS) and NanoPower MSP (6 cell) mounted on the 3U side of a 6U structure

2.1 Highlighted Features

- Easy integration with other GomSpace products
- Flight Preparation Panel
 - USB Hub interfaces with ESD and noise protection
 - 3 USB connectors to connect to 3 other sub modules inside the satellite
 - Remove Before Flight (RBF) pins
 - Satellite charging interface
 - Battery voltage sensing pins
 - Kill Switch on/off
 - CAN interface
- PCB material: glass/polyimide
- IPC-A-610 Class 3 assembly

2.2 Utility Plate and PCB Mounting

The utility plate is an 83 x 53 x 6 mm aluminum plate with M2.5 countersunk screw holes in each corner used for mounting on the 3U side of GomSpace NanoStructure 6U frame.

The PCB is mounted from the bottom, so the Flight Preparation pins pointing outwards. Between the plate and the PCB are four M2x1.5mm spacers. M2x5 screws are used.

The plate contains room for two other items: a GomSpace NanoSense Fine Sun Sensor and a GPS antenna (see chapter 8). These are ordered separately.

2.3 Block Diagram

The block diagram below shows the communication and power pathways through the MSP-FPP system. Connected subsystems are shown on the edges.

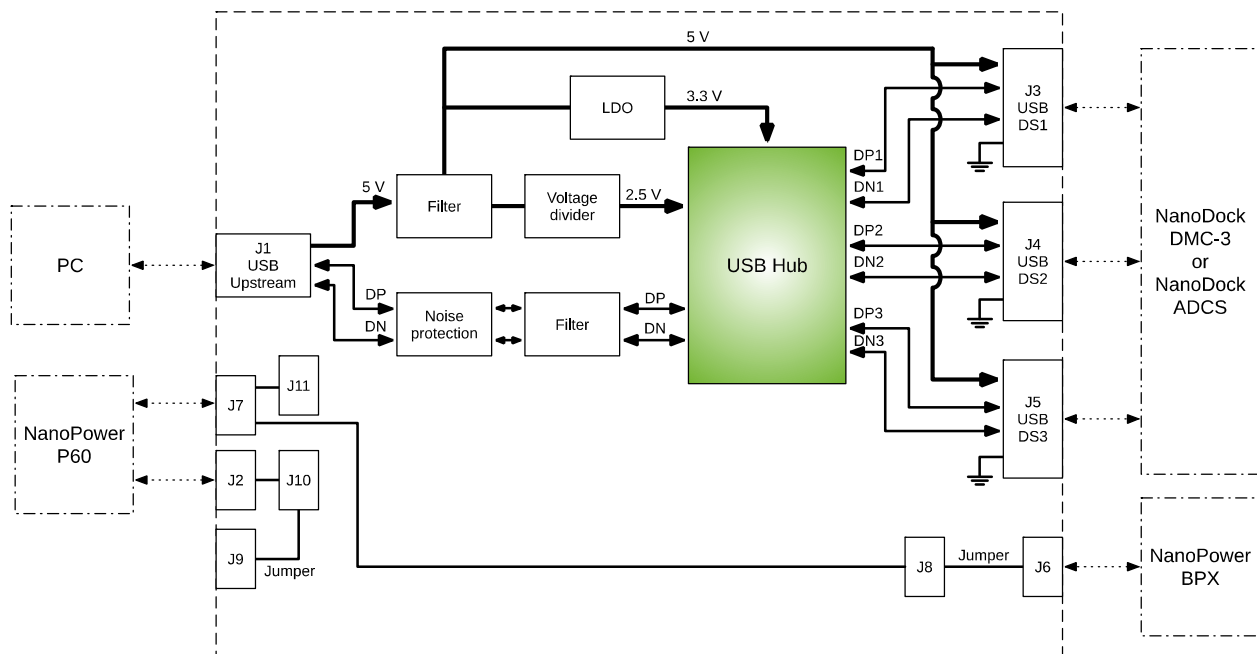

3 Hardware Layout

3.1 Connector Location Top

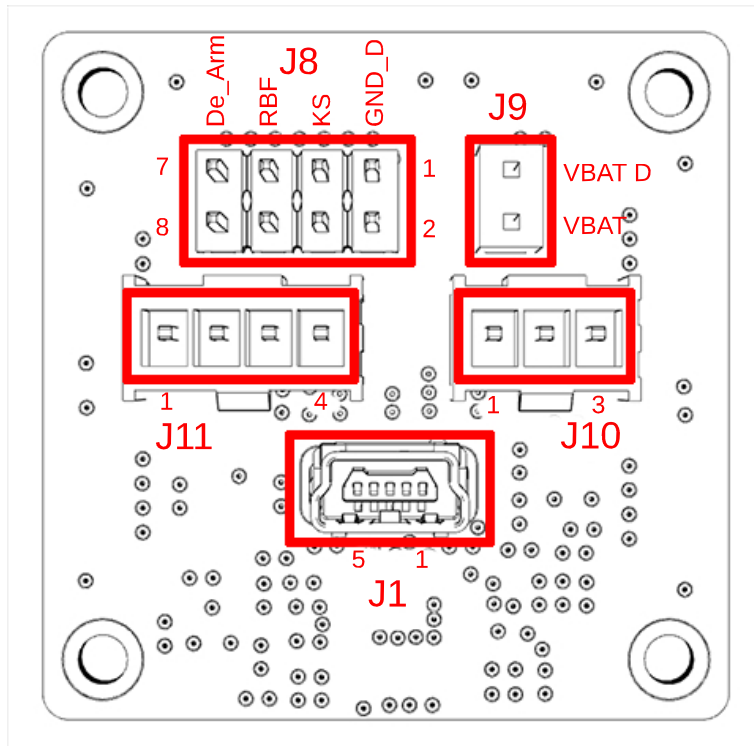

3.1.1 J1 – Standard Mini USB

Mini USB Type AB. 500075-0517 USB Connector.

Connect to PC.

3.1.2 J8 – Flight Preparation Panel Pins

TSW-104-07-S-D connector. 2.54 mm two rows Header

Pin	Description
1	GND_D
2	GND
3	KS
4	GND
5	RBF
6	GND
7	De-Arm
8	GND

Use 2.54 mm female jumpers.

RBF - Remove Before Flight

The RBF is connected to the EPS RBF and by shorting it to ground ensures that the satellite cannot be switch on.

Kill Switch

There are two kill switch pins. By shorting KS to ground the satellite will turn on. By shorting Kill Switch Reset it will turn off.

De-Arm

The De-Arm is an active low input in P60 (NanoPower). When active; the antenna release system is deactivated. This prevents unintentional antenna releases and it is recommended that this input be connected such that a jumper can be inserted shorting this input to ground.

Charging the batteries (see chapter 3.1.3 and 4.1.4)

If the high current VBAT circuit breaker is used in P60-Dock, then V_BAT and V_BAT_D (J9) need to be connected to the P60-Dock. On the GomSpace NanoPower BPX and BP4 battery packs there is a connector for a high current GND circuit breaker. If this is used, then you also need to connect the MSP-FPP to BPX/BP4.

With these connections from MSP-FPP to P60-Dock and BPX then a procedure for charging the batteries in a spacecraft is:

- 1) Connect the battery charger to GND, V_BAT_SENSE and V_BAT_CHARGE (J10)
- 2) Connect GND to GND_D (J8)
- 3) Connect V_BAT to V_BAT_D (J9)
- 4) Start the charger

Steps one and two only needs to be performed if the high current circuit breakers are used.

Powering up the spacecraft (see chapter 3.1.3 and 4.1.4)

When powering up the spacecraft connections from P60-Dock (P13 and P14) to MSP-FPP are needed. The spacecraft could for instance be located in the orbital deployer ready for the launch vehicle or be in the clean room.

A procedure for this is described below.

- 1) Connect GND to GND_D (J8)
- 2) Connect V_BAT to V_BAT_D (J9)
- 3) Connect KS to GND (J8)
- 4) Remove the RBF jumper (J8)

3.1.3 J9 – Battery Voltage

SSQ-101-01-G-D Connector.

Pin	Description
1	V_BAT_D
2	V_BAT

Use 2.54 mm male jumpers.

Refer to Section 4.1.2 for more detail explanation.

3.1.4 J10 - Battery Voltage Sensing Pins

IPL1-103-01-STL-S-K Connector.

Pin	Description
1	V_BAT_CHARGE
2	GND
3	V_BAT_D_SENSE

Use MMSS-03-28-S-40.00-S-K single row discrete wire cable assembly for connection.

Charge

The satellite can be charged through the V_BAT_CHARGE.

Battery Voltage

The battery voltage can be measured through the V_BAT_D_SENSE pin.

Refer to Section 3.1.2 for more detail explanation.

3.1.5 J11 - CAN Interface

IPL1-104-01-STL-S-K Connector.

Pin	Description
1	GND
2	GND
3	CANL
4	CANH

Use MMSS-04-28-S-40.00-S-K single row discrete wire cable assembly for connection.

3.2 Connector Location Bottom

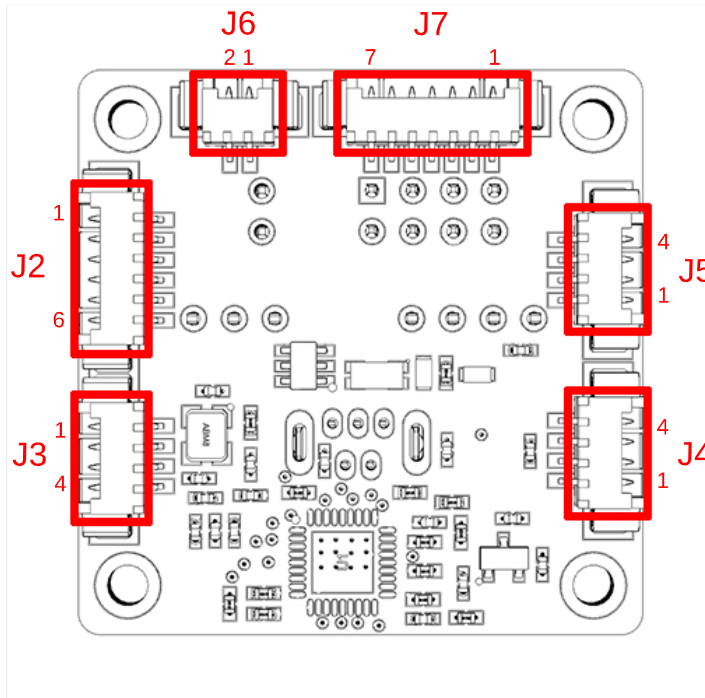

3.2.1 J2 – Connect to NanoPower P60 Dock (connector P13)

PicoBlade 1.25 mm Pitch. Right Angle. Molex 53261-0671.

Pin	Description
1	V_BAT
2	V_BAT_D
3	V_BAT_D_CHARGE
4	V_BAT_D_SENSE
5	GND
6	GND

3.2.2 J3 – Connect to Sub Modules with USB Interface

PicoBlade 1.25 mm Pitch. Straight. Molex 0532610471.

Pin	Description
1	USBDN_DP
2	USBDN_DN
3	USB 5V
4	GND

3.2.3 J4 – Connect to Sub Modules with USB Interface

PicoBlade 1.25 mm Pitch. Straight. Molex 0532610471.

Pin	Description
1	USBDN_DP
2	USBDN_DN
3	USB 5V
4	GND

3.2.4 J5 – Connect to Sub Modules with USB Interface

PicoBlade 1.25 mm Pitch. Straight. Molex 0532610471.

Pin	Description
1	USBDN_DP
2	USBDN_DN
3	USB 5V
4	GND

3.2.5 J6 – Connect to NanoPower BPX (connector PGND1)

PicoBlade 1.25 mm Pitch. Right Angle. Molex 53261-0271.

Pin	Description
1	GND_D
2	GND

If you are not using the high current ground serial breakers then do not connect J6 to BPX.

3.2.6 J7 - Connect to NanoPower P60 Dock (connector P14)

PicoBlade 1.25 mm Pitch. Right Angle. Molex 53261-0771.

Pin	Description
1	De-Arm
2	RBF
3	GND
4	KS
5	GND
6	CANH
7	CANL

4 Absolute Maximum Ratings

Stresses above those listed under Absolute Maximum Rating may cause permanent damage to the device. Exposure to absolute maximum rating conditions for extended periods may effect the reliability.

Parameter	Description	Min	Typ.	Max	Unit
T _{op}	Operational temperature range	-40		85	°C
T _{st}	Storage temperature range	-40		85	°C
I	Supply current draw on J2 connector			1.2	A

5 Physical Characteristics

Description	Value	Unit
Mass (plate + PCB)	20.3 + 8.0 = 28.3	g
Size of PCB	35.1 x 35.1 x 17.0	mm
Size of plate	82.6 x 53.2 x 5.5	mm

6 Disclaimer

The information in this document is subject to change without notice and should not be construed as a commitment by GomSpace. GomSpace assumes no responsibility for any errors that may appear in this document.

In no event shall GomSpace be liable for incidental or consequential damages arising from use of this document or the software and hardware described in this document.

7 Mechanical Drawing

All dimensions in mm.

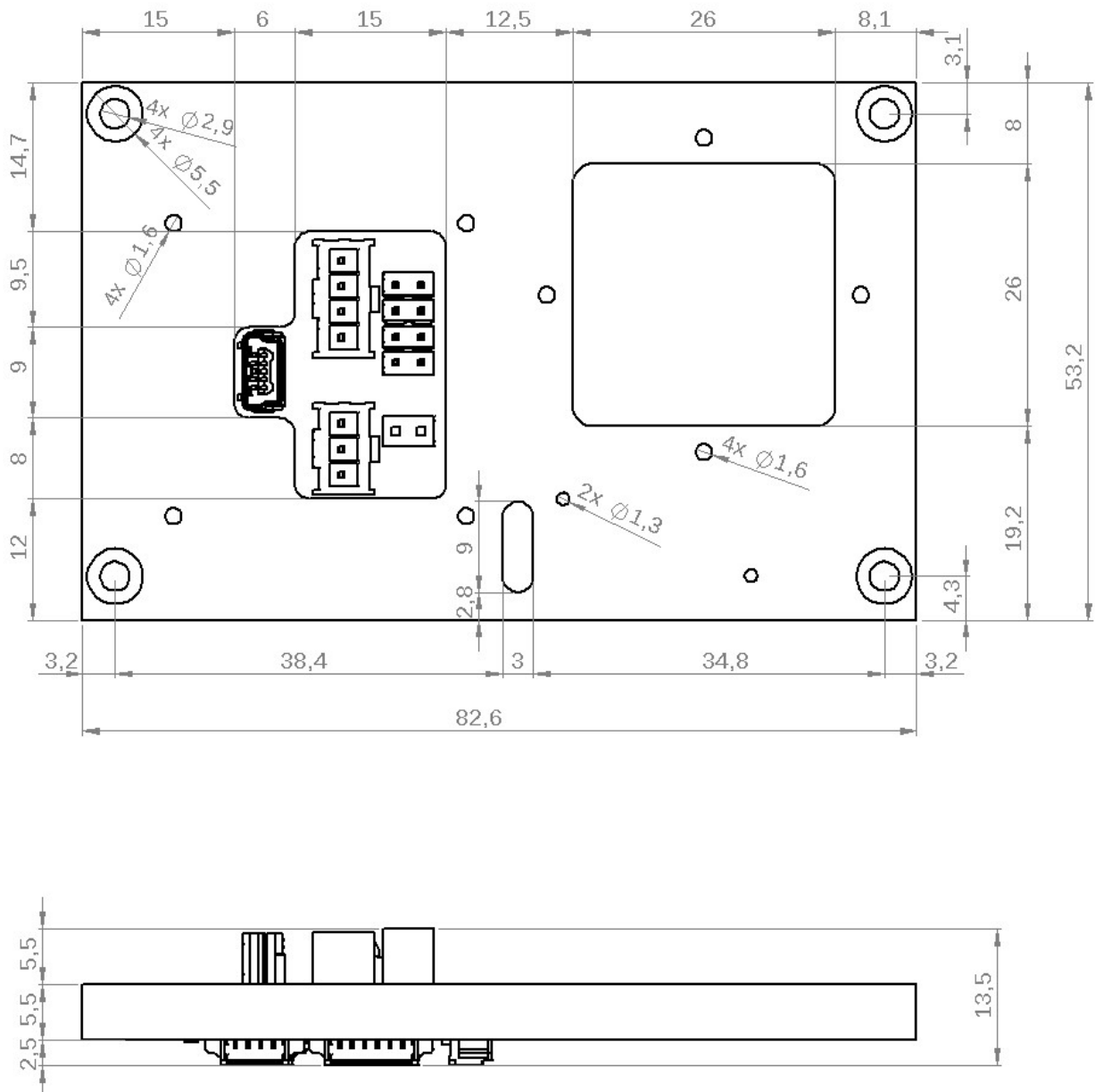

8 Using MSP-FPP with other GomSpace Products

Below is a drawing, which illustrates the placement of the FPP, antenna and FSS.

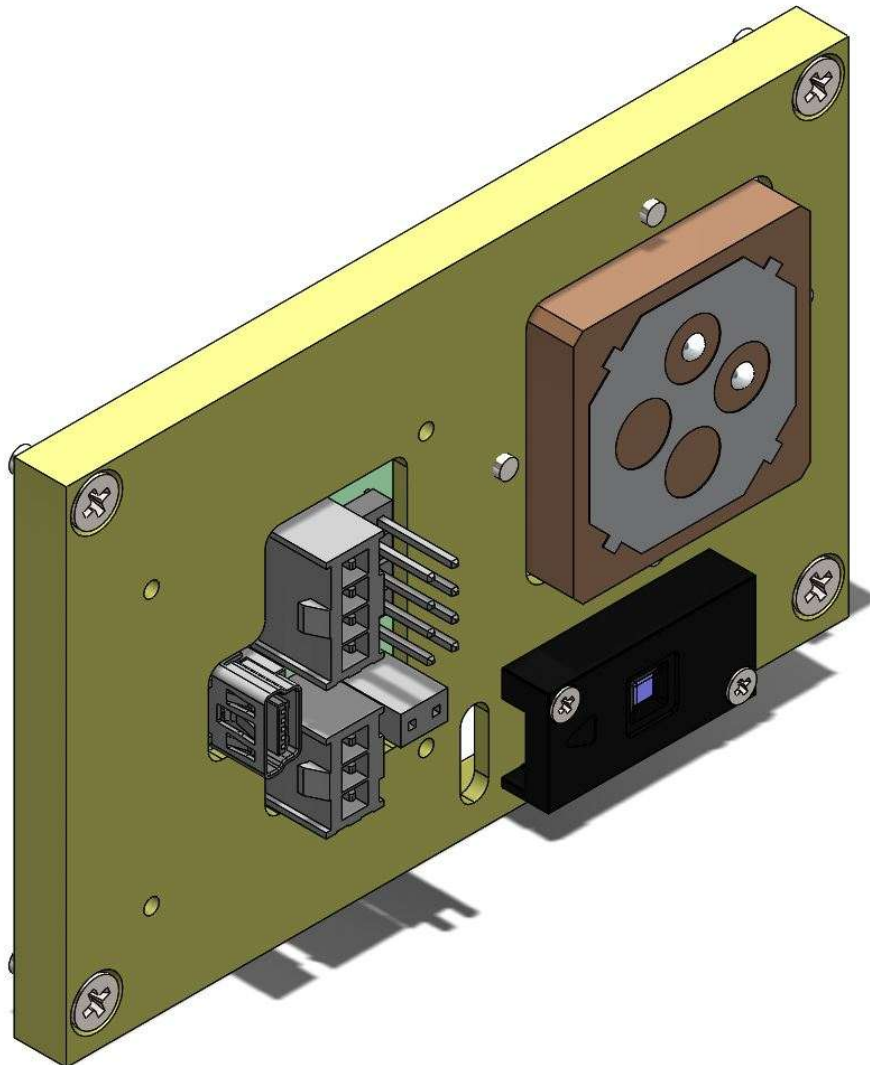

The mounting bracket accommodates the MSP-FPP on the left, TW1421 GPS Antenna and a GomSpace NanoSense Fine Sun Sensor on the right side. The full system will be located on the 3U side of the 6U structure on the side of the structure without kill switches.